

# SECTION 9: PARTS

We do our best to stock replacement parts when possible, but we cannot guarantee that all parts shown are available for purchase. Call (800) 523-4777 or visit [www.grizzly.com/parts](http://www.grizzly.com/parts) to check for availability.

## G1033/G1033Z Main

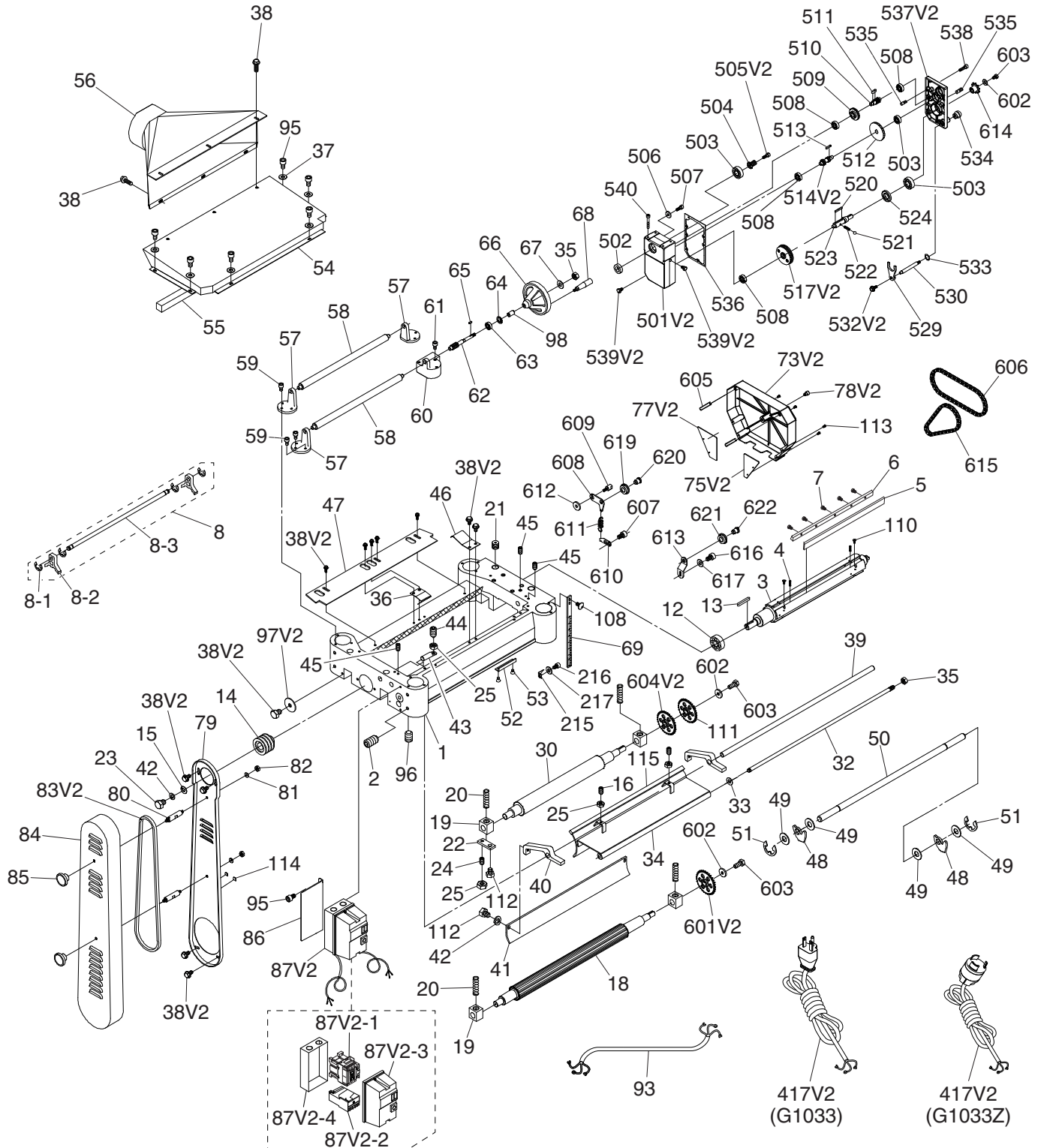

# G1033/G1033Z Main Parts List

REF	PART #	DESCRIPTION
1	P1033001	HEADSTOCK CASTING
2	P1033002	SET SCREW M10-1.5 X 12
3	P1033003	CUTTERHEAD 20" 4-KNIFE
4	P1033004	COMPRESSION SPRING 0.6 X 5.9 X 16
5	P1033005	20" PLANER KNIVES-SET OF 4
6	P1033006	CUTTERHEAD GIB
7	P1033007	HEX BOLT M8-1.25 X 10
8	P1033008	KNIFE-SETTING JIG ASSEMBLY
8-1	P1033008-1	E-CLIP 9MM
8-2	P1033008-2	KNIFE-SETTING JIG FOOT
8-3	P1033008-3	KNIFE-SETTING JIG SHAFT
12	P1033012	BALL BEARING 6206-2RS
13	P1033013	KEY 8 X 8 X 36
14	P1033014	CUTTERHEAD PULLEY
15	P1033015	FENDER WASHER 8 X 30 X 4MM
16	P1033016	SET SCREW M6-1 X 12
18	P1033018	INFEED ROLLER
19	P1033019	BUSHING BLOCK
20	P1033020	COMPRESSION SPRING 3.5 X 19.7 X 70
21	P1033021	TENSIONING SET SCREW M22-1.5 X 20
22	P1033022	BUSHING BLOCK PLATE
23	P1033023	HEX BOLT M8-1.25 X 30
24	P1033024	SET SCREW M6-1 X 16
25	P1033025	HEX NUT M6-1 THIN
30	P1033030	OUTFEED ROLLER
32	P1033032	CHIP BREAKER PIVOT ROD M12-1.75 X 25
33	P1033033	EXT RETAINING RING 12MM
34	P1033034	CHIP BREAKER
35	P1033035	HEX NUT M12-1.75
36	P1033036	V-ANGLED SPRING 70 X 46 X 0.6MM
37	P1033037	FLAT WASHER 6MM
38	P1033038	HEX BOLT M6-1 X 12
38V2	P1033038V2	FLANGE BOLT M6-1 X 12 V2.05.18
39	P1033039	CHIPBREAKER ADJUSTMENT ROD
40	P1033040	CHIPBREAKER ADJUSTMENT BRACKET
41	P1033041	PRESSURE BAR
42	P1033042	LOCK WASHER 8MM
43	P1033043	SHAFT
44	P1033044	SET SCREW M6-1 X 20
45	P1033045	SET SCREW M6-1 X 16
46	P1033046	FLAT SPRING 84 X 46 X 0.6MM
47	P1033047	CHIP DEFLECTOR
48	P1033048	ANTI-KICKBACK FINGER
49	P1033049	SPACER
50	P1033050	ANTI-KICKBACK SHAFT
51	P1033051	E-CLIP 15MM
52	P1033052	DEPTH LIMITER
53	P1033053	FLAT HD SCR M5-.8 X 12
54	P1033054	UPPER COVER
55	P1033055	UPPER COVER GASKET

REF	PART #	DESCRIPTION
56	P1033056	DUST PORT 5"
57	P1033057	RETURN ROLLER BRACKET
58	P1033058	RETURN ROLLER
59	P1033059	CAP SCREW M6-1 X 16
60	P1033060	WORM GEAR HOUSING
61	P1033061	CAP SCREW M6-1 X 50
62	P1033062	WORM SHAFT
63	P1033063	BALL BEARING 6201-2RS
64	P1033064	INT RETAINING RING 32MM
65	P1033065	KEY 4 X 4 X 10
66	P1033066	HANDWHEEL TYPE-2 200D X 12B-K X 3/8-16
67	P1033067	FLAT WASHER 12MM
68	P1033068	REVOLVING HANDLE 1 X 3-9/16, 3/8-16 X 1/2
69	P1033069	SCALE
73V2	P1033073V2	DRIVE CHAIN COVER V2.05.18
75V2	P1033075V2	GEARBOX COVER PLATE-A V2.05.18
77V2	P1033077V2	GEARBOX COVER PLATE-B V2.05.18
78V2	P1033078V2	CAP SCREW M8-1.25 X 10 V2.05.18
79	P1033079	PULLEY GUARD
80	P1033080	STANDOFF-HEX DE
81	P1033081	FLAT WASHER 5/16
82	P1033082	HEX NUT 5/16-18
83V2	P1033083V2	V-BELT M58 3L580 V2.05.18
84	P1033084	PULLEY COVER
85	P1033085	KNOB 5/16-18, D1-3/4, ROUND
86	P1033086	SWITCH BRACKET (G1033)
86	P1033Z086	SWITCH BRACKET (G1033Z)
87V2	P1033087V2	MAGNETIC SWITCH ASSY SDE MP-18 V2.05.18
87V2	P1033Z087V2	MAGNETIC SWITCH ASSY SDE MP-30 V2.05.18
87V2-1	P1033087V2-1	CONTACTOR SDE MA-18 220-240V (G1033)
87V2-1	P1033Z087V2-1	CONTACTOR SDE MA-30 220-240V (G1033Z)
87V2-2	P1033087V2-2	OL RELAY SDE RA-30 18-26A (G1033)
87V2-2	P1033Z087V2-2	OL RELAY SDE RA-30 22-34A (G1033Z)
87V2-3	P1033087V2-3	MAGNETIC SWITCH COVER (FRONT) (G1033)
87V2-3	P1033Z087V2-3	MAGNETIC SWITCH COVER (FRONT) (G1033Z)
87V2-4	P1033087V2-4	MAGNETIC SWITCH COVER (REAR) (G1033)
87V2-4	P1033Z087V2-4	MAGNETIC SWITCH COVER (REAR) (G1033Z)
93	P1033093	MOTOR CORD 12G 3W 57" (G1033)
93	P1033Z093	MOTOR CORD 10G 3W 57" (G1033Z)
95	P1033095	CAP SCREW M6-1 X 12
96	P1033096	SET SCREW M8-1.25 X 12
97V2	P1033097V2	FENDER WASHER 6 X 22 X 3MM V2.05.18
98	P1033098	SLEEVE 13.5 ID X 30 L
108	P1033108	PHLP HD SCR M6-1 X 12
110	P1033110	FLAT HD CAP SCR M5-.8 X 10
111	P1033111	SPROCKET 31T
112	P1033112	HEX BOLT M8-1.25 X 20
113	P1033113	PHLP HD SCR M4-.7 X 8
114	P1033114	PULLEY GUARD PLATE
115	P1033115	CHIP BREAKER GASKET



# G1033/G1033Z Main Parts List (Cont.)

REF	PART #	DESCRIPTION
215	P1033215	POINTER
216	P1033216	CAP SCREW M5-.8 X 10
217	P1033217	LOCK WASHER 5MM
417V2	P1033417V2	POWER CORD 12G 3W 138" 6-20P V2.05.18
417V2	P1033Z417V2	POWER CORD 12G 3W 138" L6-30P V2.05.18
501V2	P1033501V2	GEARBOX V2.05.18
502	P1033502	OIL SEAL 28 X 40 X 8
503	P1033503	BALL BEARING 6204ZZ
504	P1033504	GEAR 16T
505V2	P1033505V2	CAP SCREW M6-1 X 25 V2.05.18
506	P1033506	FLAT WASHER 6 X 20 X 3MM
507	P1033507	CAP SCREW M6-1 X 12
508	P1033508	BALL BEARING 6201ZZ
509	P1033509	GEAR 47T
510	P1033510	GEARED SHAFT 18T
511	P1033511	KEY 5 X 5 X 12
512	P1033512	GEAR 71T
513	P1033513	KEY 5 X 5 X 10
514	P1033514	GEARED SHAFT 22T/18T
517	P1033517	COMBO GEAR 92T/96T
520	P1033520	KEY 6 X 6 X 40
521	P1033521	STEEL BALL 6MM
522	P1033522	COMPRESSION SPRING 0.6 X 5.9 X 16
523	P1033523	GEAR SHAFT
524	P1033524	OIL SEAL 25 X 47 X 6
529	P1033529	SHIFTING FORK
530	P1033530	SHIFTING SHAFT
532V2	P1033532V2	FLANGE BOLT M6-1 X 12 V2.05.18
533	P1033533	O-RING 12 X 1.5 S12.5

REF	PART #	DESCRIPTION
534	P1033534	KNOB 3/8-16, D1-1/4, BALL
535	P1033535	LOCATING PIN 8 X 7.55 X 7.95
536	P1033536	GEARBOX COVER GASKET
537V2	P1033537V2	GEARBOX COVER V2.05.18
538	P1033538	CAP SCREW M6-1 X 25
539V2	P1033539V2	OIL PLUG 1/4 NPT X 3/4" V2.05.18
540	P1033540	CAP SCREW M8-1.25 X 50
601V2	P1033601V2	SPROCKET 31T V2.05.18
602	P1033602	FENDER WASHER 6 X 20 X 3MM
603	P1033603	HEX BOLT M6-1 X 16
604V2	P1033604V2	SPROCKET 31T V2.05.18
605	P1033605	ROLL PIN 6 X 20
606	P1033606	CHAIN 06B-1 X 67 33 LINKS
607	P1033607	CAP SCREW M6-1 X 10
608	P1033608	CHAIN TENSIONER
609	P1033609	SHOULDER BOLT M8-1.25 X 14, 12 X 4
610	P1033610	SPRING BRACKET
611	P1033611	EXTENSION SPRING 1 X 8.5 X 33
612	P1033612	SPACER 8.2 X 22 X 3MM
613	P1033613	OUTER CHAIN TENSIONER
614	P1033614	SPROCKET 12T W/KEY
615	P1033615	CHAIN 06B-1 25 LINKS
616	P1033616	CAP SCREW M6-1 X 35
617	P1033617	FLAT WASHER 6MM
619	P1033619	CHAIN TENSIONER IDLER WHEEL
620	P1033620	CHAIN TENSIONER IDLER SHAFT
621	P1033621	OUTER CHAIN TENSIONER IDLER WHEEL
622	P1033622	OUTER CHAIN TENSIONER IDLER SHAFT



# G1033/G1033Z Stand & Motor

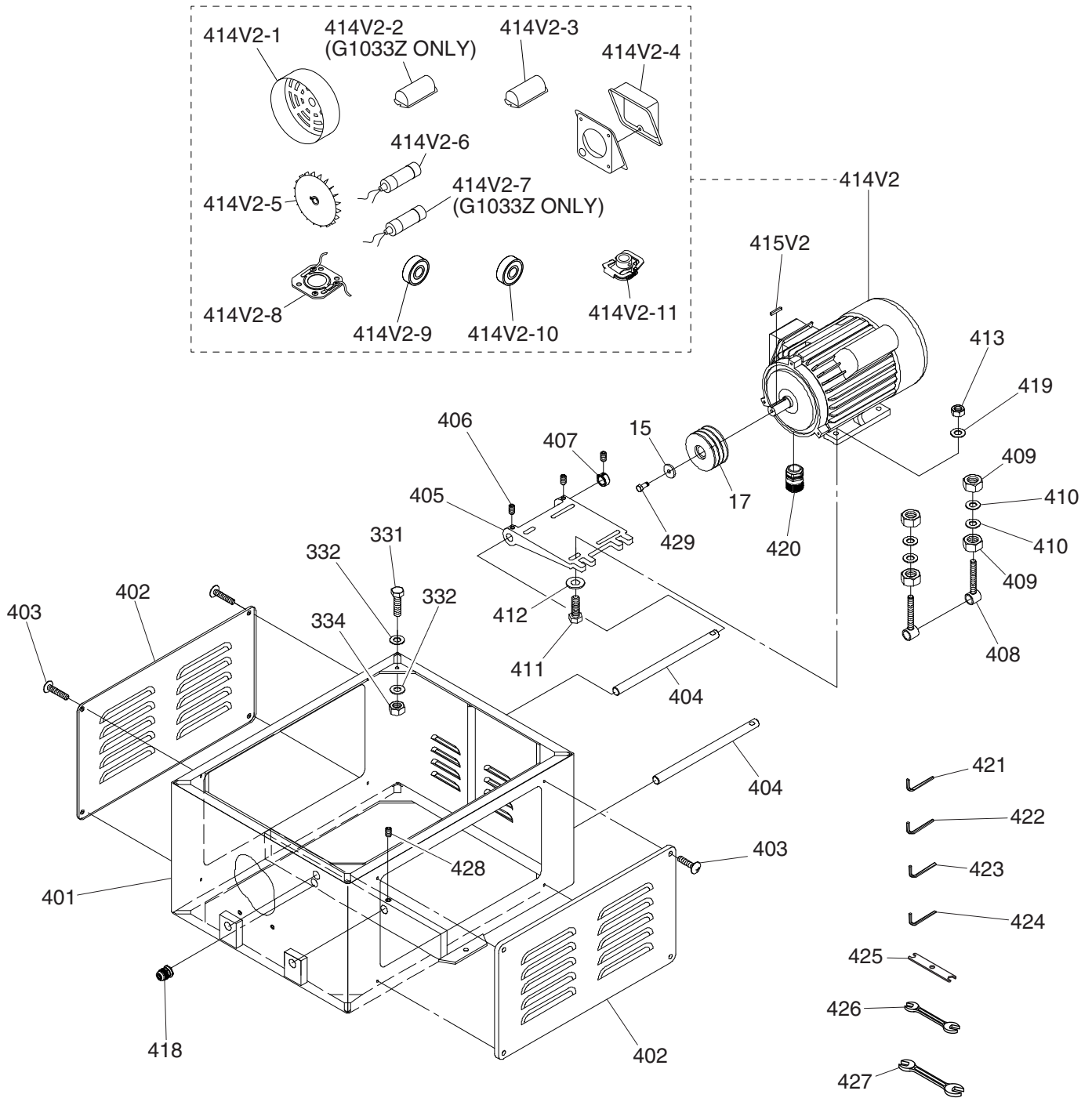

# G1033/G1033Z Stand & Motor Parts List

REF	PART #	DESCRIPTION
15	P1033015	FENDER WASHER 8 X 30 X 4MM
17	P1033017	MOTOR PULLEY (G1033)
17	P1033Z017	MOTOR PULLEY (G1033Z)
331	P1033331	HEX BOLT M12-1.75 X 50
332	P1033332	FLAT WASHER 12MM
334	P1033334	HEX NUT M12-1.75
401	P1033401	STAND
402	P1033402	MOTOR ACCESS PANEL
403	P1033403	FLAT HD SCR M6-1 X 20
404	P1033404	PLATE CONNECTING ROD
405	P1033405	MOTOR MOUNT PLATE (G1033)
405	P1033Z405	MOTOR MOUNT PLATE (G1033Z)
406	P1033406	SET SCREW M8-1.25 X 12
407	P1033407	COLLAR
408	P1033408	ROD END BOLT M12-1.75 X 105, ID 20MM
409	P1033409	HEX NUT M12-1.75
410	P1033410	FLAT WASHER 12MM
411	P1033411	HEX BOLT M8-1.25 X 40
412	P1033412	FENDER WASHER 8 X 22 X 3MM
413	P1033413	HEX NUT M8-1.25
414V2	P1033414V2	MOTOR 3HP 230V 1-PH V2.05.18 (G1033)
414V2	P1033Z414V2	MOTOR 5HP 230V 1-PH V2.05.18 (G1033Z)
414V2-1	P1033414V2-1	MOTOR FAN COVER (G1033)
414V2-1	P1033Z414V2-1	MOTOR FAN COVER (G1033Z)
414V2-2	P1033Z414V2-2	CAPACITOR COVER (RUN) (G1033Z)
414V2-3	P1033414V2-3	CAPACITOR COVER (START) (G1033)
414V2-3	P1033Z414V2-3	CAPACITOR COVER (START) (G1033Z)
414V2-4	P1033414V2-4	MOTOR JUNCTION BOX (G1033)

REF	PART #	DESCRIPTION
414V2-4	P1033Z414V2-4	MOTOR JUNCTION BOX (G1033Z)
414V2-5	P1033414V2-5	MOTOR FAN (G1033)
414V2-5	P1033Z414V2-5	MOTOR FAN (G1033Z)
414V2-6	P1033Z414V2-6	R CAPACITOR 60M 350V 1-3/4 X 4-5/16 (G1033Z)
414V2-7	P1033414V2-7	S CAPACITOR 600M 125V 1-3/4 X 3-5/16 (G1033)
414V2-7	P1033Z414V2-7	S CAPACITOR 600M 125V 1-3/4 X 3-5/16 (G1033Z)
414V2-8	P1033414V2-8	CONTACT PLATE (G1033)
414V2-8	P1033Z414V2-8	CONTACT PLATE (G1033Z)
414V2-9	P1033414V2-9	BALL BEARING 6205ZZ (FRONT) (G1033)
414V2-9	P1033Z414V2-9	BALL BEARING 6205ZZ (FRONT) (G1033Z)
414V2-10	P1033414V2-10	BALL BEARING 6203ZZ (REAR) (G1033)
414V2-10	P1033Z414V2-10	BALL BEARING 6203ZZ (REAR) (G1033Z)
414V2-11	P1033414V2-11	CENTRIFUGAL SWITCH (G1033)
414V2-11	P1033Z414V2-11	CENTRIFUGAL SWITCH (G1033Z)
415V2	P1033415V2	KEY 5 X 5 X 30 V2.05.18
418	P1033418	STRAIN RELIEF TYPE-3 M25-1.5
419	P1033419	FLAT WASHER 8MM
420	P1033420	STRAIN RELIEF TYPE-3 M25-1.5
421	P1033421	HEX WRENCH 3MM
422	P1033422	HEX WRENCH 4MM
423	P1033423	HEX WRENCH 5MM
424	P1033424	HEX WRENCH 6MM
425	P1033425	FLAT WRENCH 10 X 13MM OPEN-ENDS
426	P1033426	WRENCH 12 X 14MM OPEN-ENDS
427	P1033427	WRENCH 17 X 19MM OPEN-ENDS
428	P1033428	SET SCREW M8-1.25 X 16
429	P1033429	HEX BOLT M8-1.25 X 30



# G1033/G1033Z Table & Base

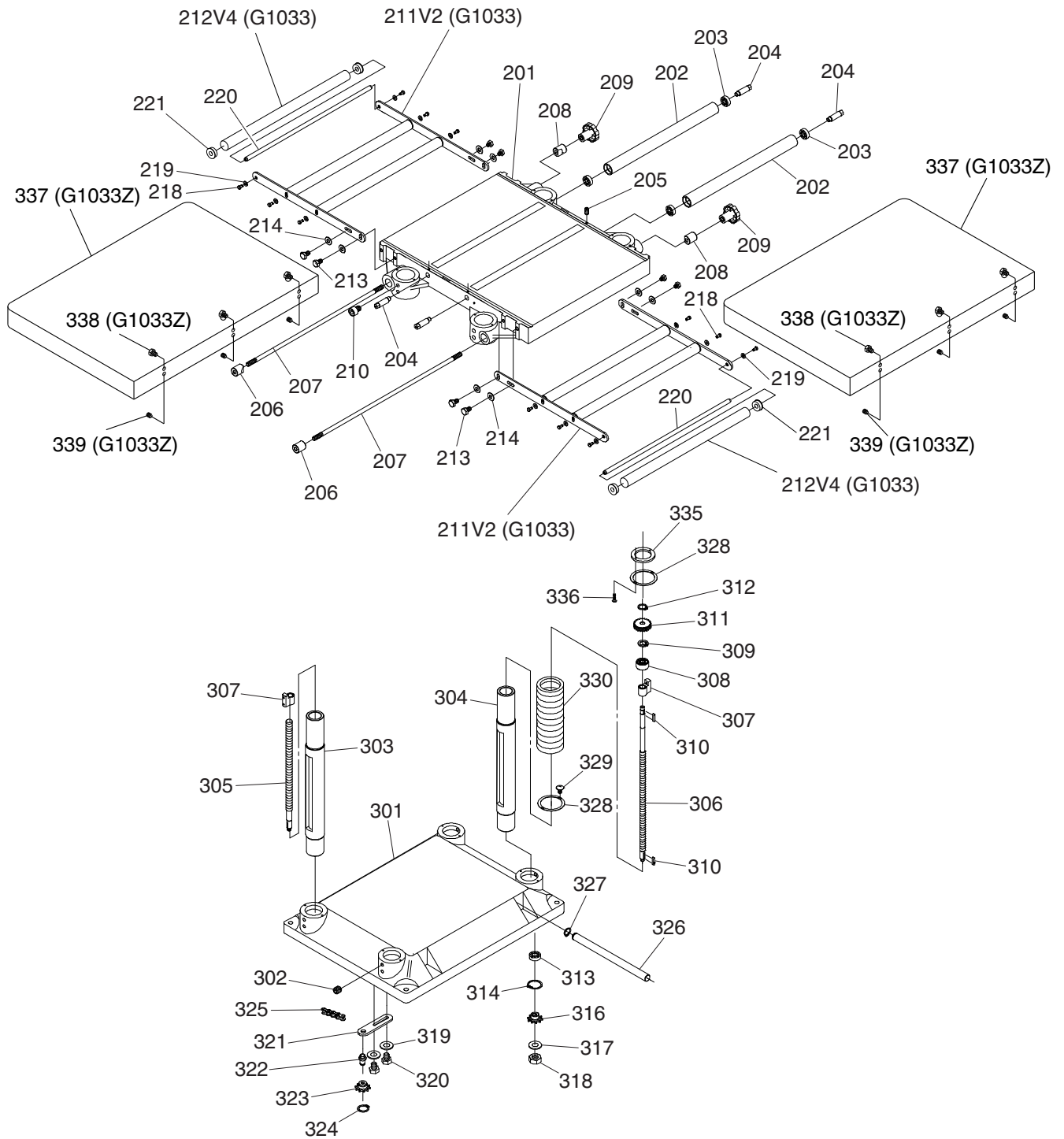

# G1033/G1033Z Table & Base Parts List

REF	PART #	DESCRIPTION
201	P1033201	MAIN TABLE
202	P1033202	MAIN TABLE ROLLER
203	P1033203	BALL BEARING 6201-2RS
204	P1033204	ECCENTRIC SHAFT
205	P1033205	SET SCREW M6-1 X 12
206	P1033206	THREADED GIB
207	P1033207	LOCKING ROD
208	P1033208	GIB
209	P1033209	KNOB 6-LOBE M12-1.75, D53
210	P1033210	CAP SCREW M8-1.25 X 16
211V2	P1033211V2	EXT ROLLER BRACKET V2.03.05 (G1033)
212V4	P1033212V4	EXTENSION TABLE ROLLER V4.05.18 (G1033)
213	P1033213	HEX BOLT M10-1.5 X 25
214	P1033214	FENDER WASHER 13MM
218	P1033218	HEX BOLT M6-1 X 12
219	P1033219	FLAT WASHER 8MM
220	P1033220	EXTENSION ROLLER AXLE
221	P1033221	EXTENSION ROLLER BUSHING, PLASTIC
301	P1033301	BASE
302	P1033302	SET SCREW M10-1.5 X 12
303	P1033303	COLUMN, SECONDARY
304	P1033304	COLUMN, PRIMARY
305	P1033305	LEADSCREW 19.05-4 X 321, SECONDARY
306	P1033306	LEADSCREW 19.05-4 X 335, PRIMARY
307	P1033307	LEADSCREW NUT 19.05-4
308	P1033308	SPACER

REF	PART #	DESCRIPTION
309	P1033309	INT RETAINING RING 38MM
310	P1033310	KEY 4 X 4 X 10
311	P1033311	GEAR 24T
312	P1033312	EXT RETAINING RING 12MM
313	P1033313	BALL BEARING 6202-2RS
314	P1033314	INT RETAINING RING 35MM
316	P1033316	SPROCKET 10T
317	P1033317	FLAT WASHER 10MM
318	P1033318	HEX NUT M10-1.25
319	P1033319	SPACER 8.2 X 22 X 3MM
320	P1033320	HEX BOLT M8-1.25 X 25
321	P1033321	IDLER BRACKET
322	P1033322	IDLER SHAFT
323	P1033323	SPROCKET 10T
324	P1033324	EXT RETAINING RING 15MM
325	P1033325	CHAIN #40 X 166
326	P1033326	LIFTING BAR
327	P1033327	EXT RETAINING RING 17MM
328	P1033328	DUST BOOT FLANGE
329	P1033329	TAP SCREW M5 X 10
330	P1033330	DUST BOOT
335	P1033335	DUST BOOT FLANGE RING
336	P1033336	TAP SCREW M5 X 16
337	P1033Z337	EXTENSION WING (G1033Z)
338	P1033Z338	HEX BOLT M8-1.25 X 25 (G1033Z)
339	P1033Z339	SET SCREW M8-1.25 X 12 (G1033Z)



# G1033/G1033Z Labels & Cosmetics

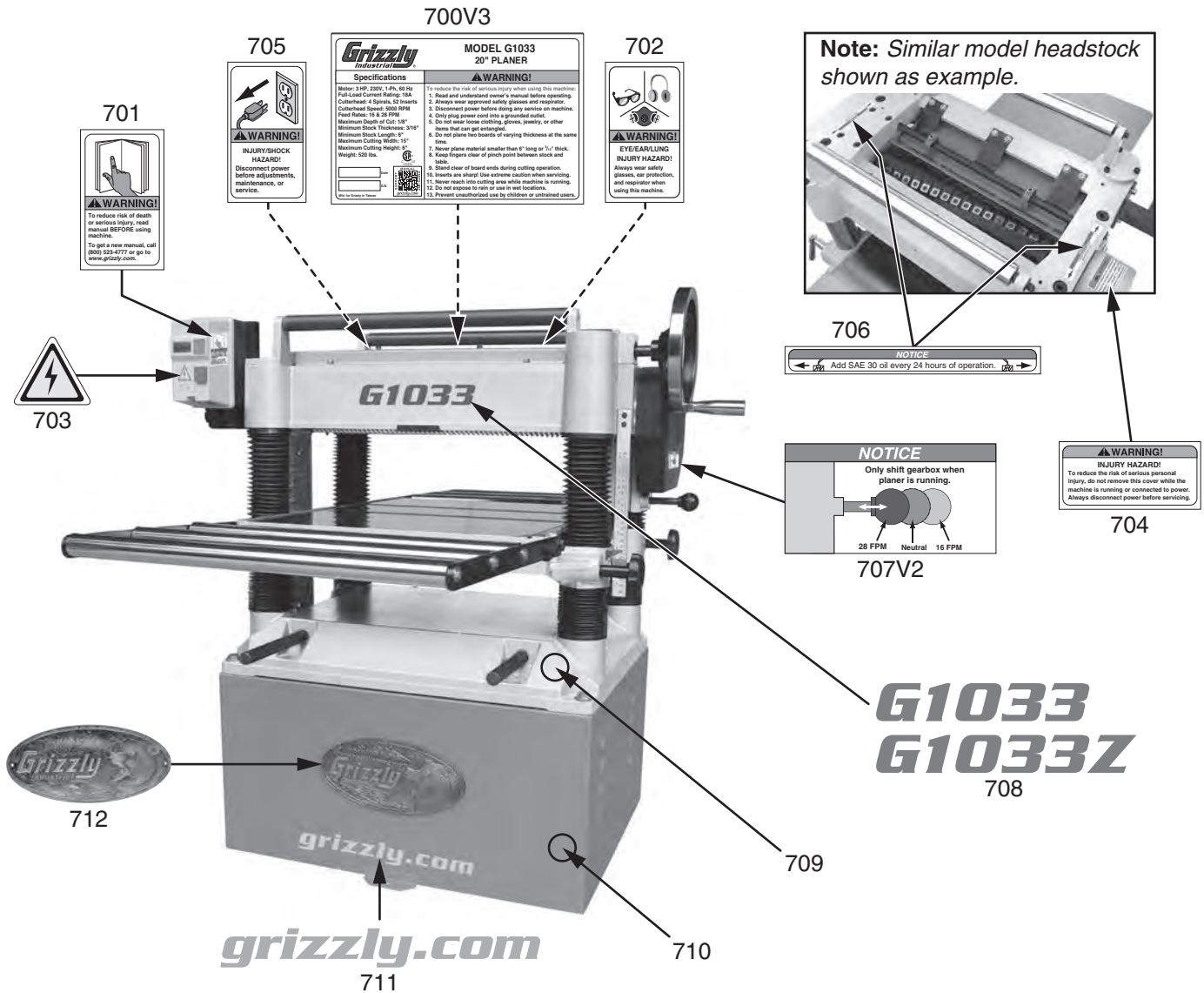

REF	PART #	DESCRIPTION
700V2	P1033700V2	MACHINE ID LABEL V2.08.18 (G1033)
700V2	P1033Z700V2	MACHINE ID LABEL V2.08.18 (G1033Z)
701	P1033701	READ MANUAL LABEL
702	P1033702	EYE/EAR/LUNG INJURY LABEL
703	P1033703	ELECTRICITY LABEL
704	P1033704	BELT COVER WARNING LABEL
705	P1033705	DISCONNECT POWER LABEL
706	P1033706	ADD OIL NOTICE

REF	PART #	DESCRIPTION
707	P1033707	SHIFT GEARBOX NOTICE
708	P1033708	MODEL NUMBER LABEL (G1033)
708	P1033Z708	MODEL NUMBER LABEL (G1033Z)
709	P1033709	TOUCH-UP PAINT, GRIZZLY PUTTY
710	P1033710	TOUCH-UP PAINT, GRIZZLY GREEN
711	P1033711	GRIZZLY.COM LABEL
712	P1033712	GRIZZLY NAMEPLATE-LARGE

## ⚠️ WARNING

Safety labels help reduce the risk of serious injury caused by machine hazards. If any label comes off or becomes unreadable, the owner of this machine **MUST** replace it in the original location before resuming operations. For replacements, contact (800) 523-4777 or [www.grizzly.com](http://www.grizzly.com).

