

G0673 Parts Breakdown

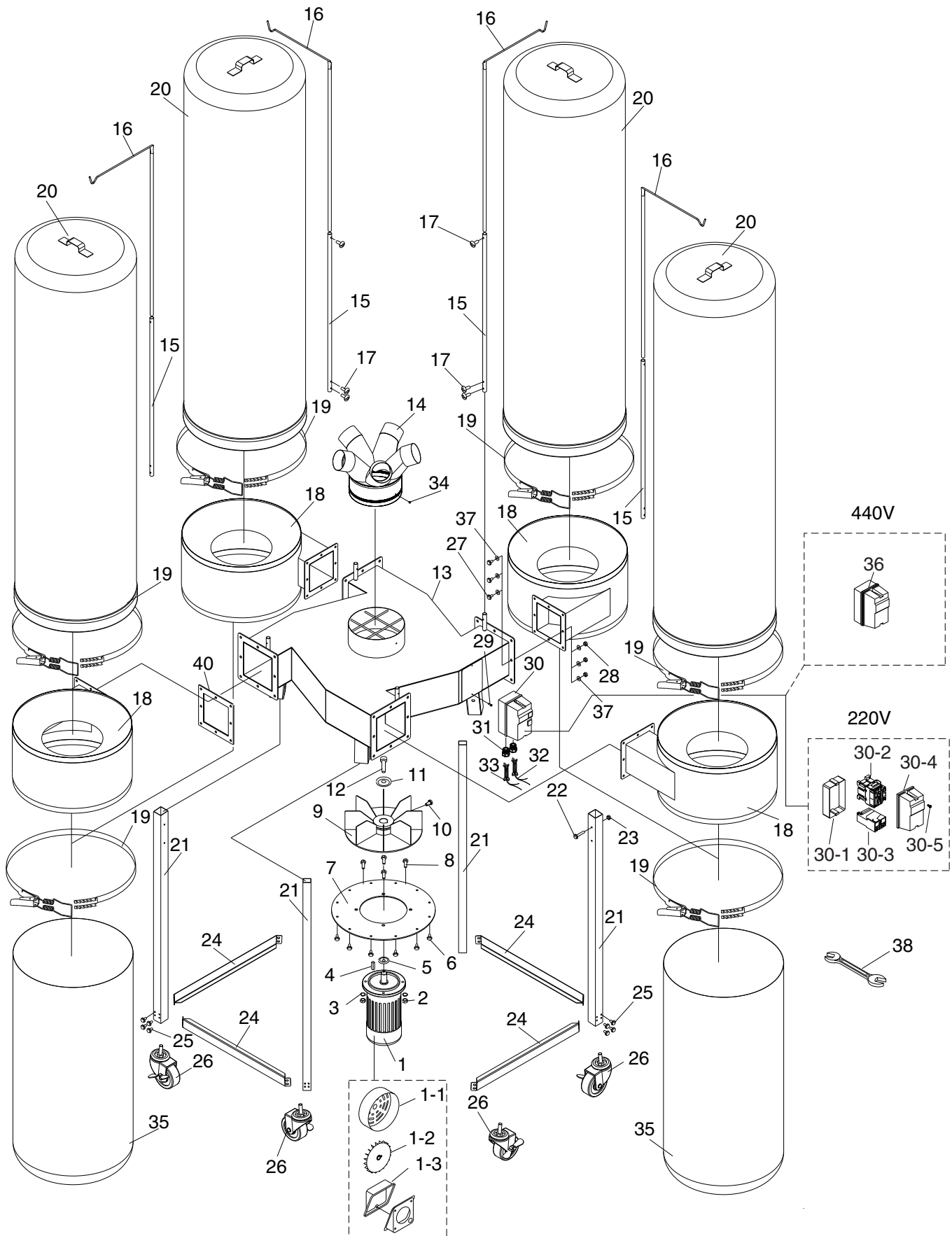

G0673 Parts List

REF	PART #	DESCRIPTION
1	P0673001	MOTOR 10HP, 220V, 3 PH
1-1	P0673001-1	FAN COVER
1-2	P0673001-2	FAN
1-3	P0673001-3	JUNCTION BOX
2	P0673002	HEX NUT 1/2"-12
3	P0673003	LOCK WASHER 1/2
4	P0673004	KEY 8 X 8 X 25
5	P0673005	MOTOR GASKET
6	P0673006	HEX BOLT 5/16-18 X 3/4
7	P0673007	INLET COVER
8	P0673008	HEX BOLT 1/2 X 1-1/2
9	P0673009	IMPELLER 17"
10	P0673010	HEX BOLT 3/8-16 X 1-1/2
11	P0673011	FLAT WASHER 6MM
12	P0673012	CAP SCREW M6-1 X 20
13	P0673013	COLLECTOR HOUSING
14	P0673014	INLET ADAPTER
15	P0673015	BAG HANGER LOWER SUPPORT
16	P0673016	BAG HANGER
17	P0673017	HEX BOLT 1/4-20 X 1/2
18	P0673018	COLLECTOR DRUM
19	P0673019	BAG CLAMP
20	P0673020	FILTER BAG 2.5 MICRON 23-5/8" X 70"
21	P0673021	LEG
22	P0673022	HEX BOLT 5/16-18 X 2-1/2
23	P0673023	HEX NUT 5/16-18
24	P0673024	LEG BRACE

REF	PART #	DESCRIPTION
25	P0673025	HEX BOLT 5/16-18 X 1/2
26	P0673026	CASTER WITH BRAKE
27	P0673027	HEX BOLT 5/16-18 X 1
28	P0673028	HEX NUT 5/16-18
29	P0673029	PHLP HD SCR 10-24 X 1/2
30	P0673030	MAGNETIC SWITCH ASSY 220V
30-1	P0673030-1	MAG SWITCH BACK COVER
30-2	P0673030-2	CONTACTOR SDE MP-30 220V 3PH
30-3	P0673030-3	OL RELAY SDE RA-30 21-35
30-4	P0673030-4	MAG SWITCH FRONT COVER
30-5	P0673030-5	PLASTIC COVER SCREW 11/32-16 X 3/4
31	P0673031	STRAIN RELIEF
32	P0673032	MOTOR CORD 10AWG X 4C
33	P0673033	POWER CORD 10AWG X 4C
34	P0673034	PHLP HD SCR 10-24 X 3/8
35	P0673035	LOWER DUST BAG 23-5/8" X 54"
36	P0673036	MAGNETIC SWITCH ASSY 440V
37	P0673037	FLAT WASHER 5/16"
38	P0673038	COMBO WRENCH 10 X 12MM
40	P0673040	RUBBER GASKET
51	P0673051	MACHINE ID LABEL
52	P0673052	GRIZZLY NAMEPLATE
53	P0673053	EAR PROTECTION 2" X 3-5/16"H
54	P0673054	GLASSES/RESPIRATOR
55	P0673055	READ MANUAL-VERTICAL NS 7/05
56	P0673056	GRIZZLY GREEN TOUCH-UP PAINT
56	P0673056	GRIZZLY GREEN TOUCH-UP PAINT



Label Placement

G0671

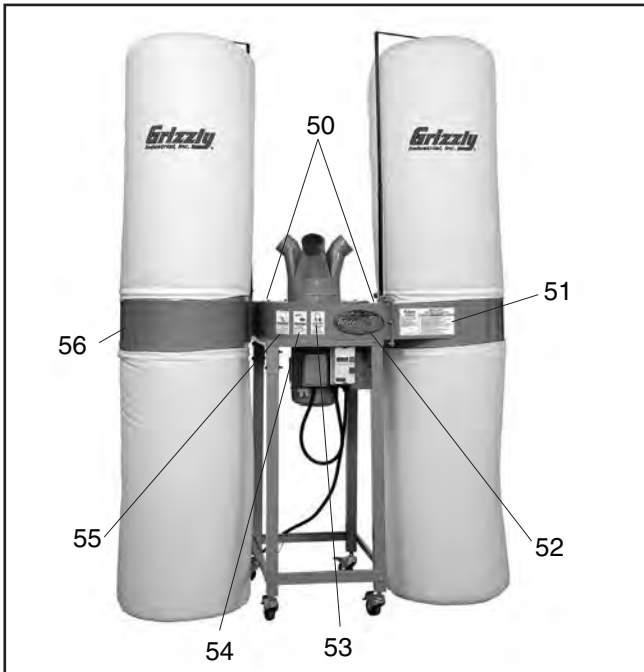

G0672

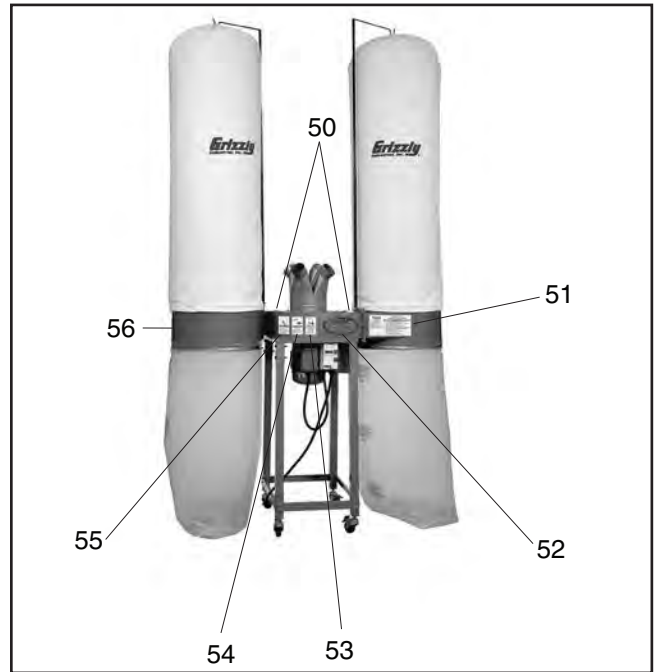

G0673

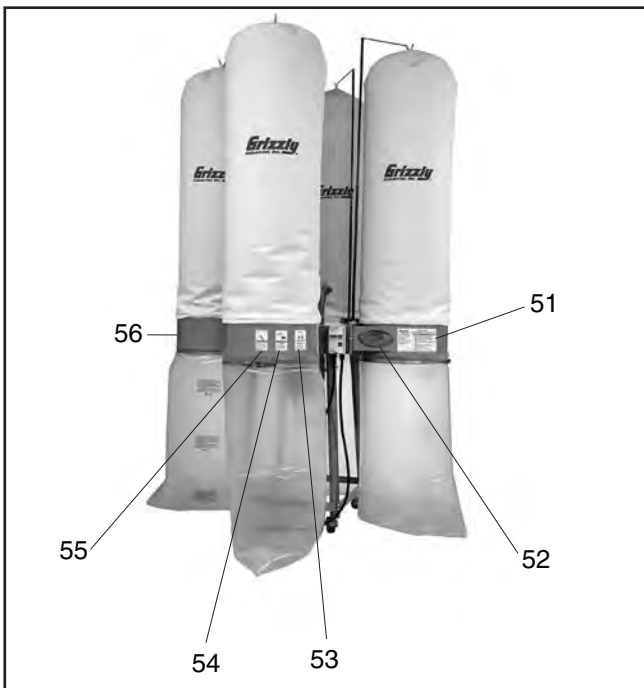

REF	PART #	DESCRIPTION
50	P0671050	HANDS INLET WARNING (G0671, G0672)
51	P0671051	MACHINE ID LABEL (G0671)
51	P0672051	MACHINE ID LABEL (G0672)
51	P0673051	MACHINE ID LABEL (G0673)
52	P0671052	GRIZZLY NAMEPLATE (G0671, G0672)
52	P0673052	GRIZZLY NAMEPLATE (G0673)
53	P0671053	EAR PROTECTION 2" X 3-5/16"H
54	P0671054	GLASSES/RESPIRATOR
55	P0671055	READ MANUAL-VERTICAL NS 7/05
56	P0671056	GRIZZLY GREEN TOUCH-UP PAINT

⚠️ WARNING

Safety labels warn about machine hazards and ways to prevent injury. The owner of this machine **MUST** maintain the original location and readability of the labels on the machine. If any label is removed or becomes unreadable, **REPLACE** that label before using the machine again. Contact Grizzly at (800) 523-4777 or www.grizzly.com to order new labels.

