

READ THIS FIRST



Model G0651

*****IMPORTANT UPDATE*****

**For Machines Mfd. Since 09/24
and Owner's Manual Revised 09/10**

For questions or help with this product contact Tech Support at (570) 546-9663 or techsupport@grizzly.com

The following changes were recently made since the owner's manual was printed:

- Labels and parts have changed.

Aside from this information, all other content in the owner's manual applies and **MUST** be read and understood for your own safety. **IMPORTANT: Keep this update with the owner's manual for future reference.**

For questions or help, contact our Tech Support at (570) 546-9663 or techsupport@grizzly.com.



COPYRIGHT © AUGUST, 2024 BY GRIZZLY INDUSTRIAL, INC.
**WARNING: NO PORTION OF THIS MANUAL MAY BE REPRODUCED IN ANY SHAPE
OR FORM WITHOUT THE WRITTEN APPROVAL OF GRIZZLY INDUSTRIAL, INC.**

#JA23310 PRINTED IN TAIWAN

Revised Parts

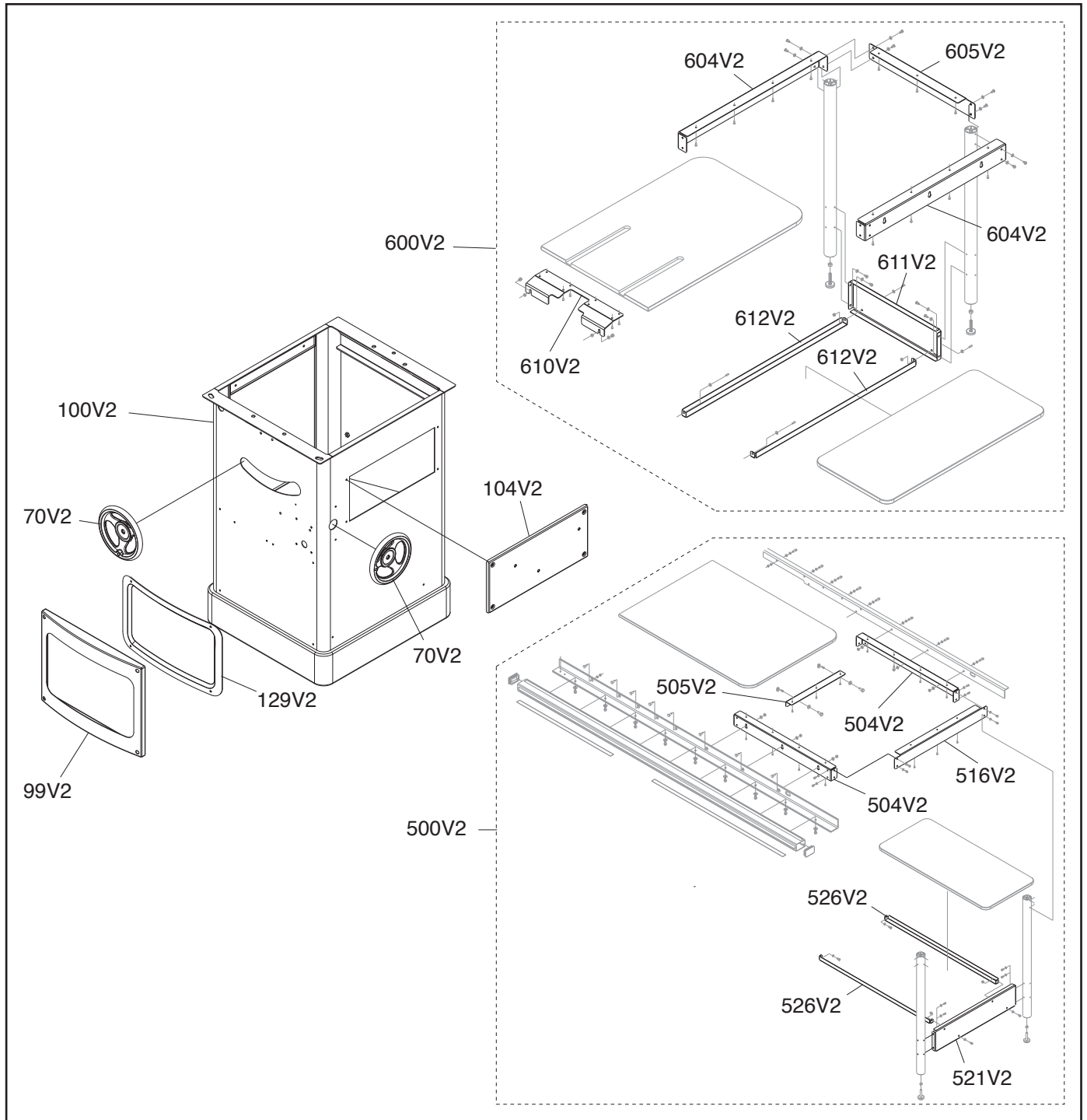

REF	PART #	DESCRIPTION
70V2	P0651070V2	HANDWHEEL V2.09.24
99V2	P0651099V2	FRONT COVER V2.09.24
100V2	P0651100V2	CABINET V2.09.24
104V2	P0651104V2	RIGHT COVER V2.09.24
129V2	P0651129V2	PLATE V2.09.24
500V2	P0651500V2	EXTENSION TABLE ASSEMBLY V2.09.24
504V2	P0651504V2	EXTENSION TABLE SUPPORT V2.09.24
505V2	P0651505V2	FRONT EXTENSION BRACKET V2.09.24
516V2	P0651516V2	EXTENSION BRACKET, RIGHT V2.09.24





REF	PART #	DESCRIPTION
521V2	P0651521V2	SHELF END PLATE V2.09.24
526V2	P0651526V2	LOWER SHELF BRACKET V2.09.24
600V2	P0651600V2	OUTFEED TABLE ASSEMBLY V2.09.24
604V2	P0651604V2	OUTFEED TABLE SUPPORT V2.09.24
605V2	P0651605V2	OUTFEED TABLE BRACKET V2.09.24
610V2	P0651610V2	FRONT OUTFEED TABLE BRACKET V2.09.24
611V2	P0651611V2	SHELF END PLATE V2.09.24
612V2	P0651612V2	LOWER SHELF BRACKET V2.09.24

BUY PARTS ONLINE AT GRIZZLY.COM!
Scan QR code to visit our Parts Store.



Label Placement

200V4-32

 AMPUTATION HAZARD! Always keep fingers and hands away from moving blade.	 WARNING! Removing blade guard increases risk of injury — MUST be installed when possible.	 WARNING! If blade guard is removed for a special cut, some other safeguard MUST be used.	 WARNING! Disconnect power before changing blades or blade guard and riving knife.
---	---	--	--

709

Grizzly Industrial		MODEL G0651	
10" HEAVY DUTY CABINET SAW w/RIVING KNIFE		WARNING!	
Specifications		To reduce risk of serious injury when using this machine:	
Motor: 3 HP, 220V, Single-Phase, 60 Hz Full Load Current Rating: 13A Arbor Speed: 4000 RPM Blade Size: 10" x 5/8" Arbor Required Blade Kerf: 0.114" - 0.122" Max. Rip Capacity: 50" Max. Depth Of Cut @ 90°: 3-3/16" Max. Depth Of Cut @ 45°: 3-3/16" Max. Chain Width: 3/8" Weight: 430 Lbs.		1. Read and understand owner's manual before operating. 2. Never touch moving blade and keep hands out of cutting path. 3. Always wear approved eye protection and respirator. 4. Always use blade guard/spreader for all through cuts; use riving knife for all non-through cuts. 5. Only use blades meeting size/speed requirements of this saw. 6. Ensure spreader/riving knife and fence are properly adjusted. 7. Never reach behind or over blade while it is moving.	
Date: _____ Serial #: _____ Manufactured for Grizzly in Taiwan.		8. Use a push stick when required and whenever possible. 9. Know what causes "kickback" and how to prevent it. 10. Do not perform any operation freehand. 11. Disconnect power before changing blades or servicing saw. 12. Plan cuts so workpieces always remain supported. 13. Do not wear loose clothing, gloves, jewelry, or other items that can get entangled. The back long hair and roll up sleeves. 14. Do not expose to rain or operate in wet environment. 15. Prevent unauthorized use by children or untrained users; restrict access or disable machine when unattended.	

713



711

714

WARNING

For Your Own Safety Read Instruction Manual Before Operating Saw:

- Wear eye protection.
- Use saw-blade guard and spreader for every operation for which it can be used, including  through sawing.
- Keep hands out of the line of saw blade.
- Use a push-stick when required.
- Pay particular attention to instructions on reducing risk of kickback.
- Do not perform any operation freehand.
- Never reach around or over saw blade.

710

WARNING!

To reduce risk of death or serious injury, read manual **BEFORE** using machine.

To get a new manual, call (800) 523-4777 or go to www.grizzly.com.

707

WARNING!



EYE/LUNG INJURY HAZARD!

Always wear safety glasses and a respirator when using this machine.

712

715

704



705



708V2

G0651

REF	PART #	DESCRIPTION
200V4-32	P0651200V4-32	BLADE GUARD WARNING LABEL
704	P0651704	GRIZZLY NAMEPLATE-LARGE
705	P0651705	EXTREME SERIES PLATE
707	P0651707	SAFETY GLASSES-HEARING LABEL
708V2	P0651708V2	MODEL NUMBER LABEL G0651 V2.09.24
709	P0651709	MACHINE ID LABEL G0651

REF	PART #	DESCRIPTION
710	P0651710	READ MANUAL-VERTICAL NS 7/05
711	P0651711	TOUCH-UP PAINT, GRIZZLY GREEN
712	P0651712	BLADE TILT ANGLE LABEL
713	P0651713	ELECTRICITY LABEL
714	P0651714	UL 987 WARNING LABEL
715	P0651715	TOUCH-UP PAINT, GLOSSY BLACK

WARNING

Safety labels help reduce the risk of serious injury caused by machine hazards. If any label comes off or becomes unreadable, the owner of this machine **MUST** replace it in the original location before resuming operations. For replacements, contact (800) 523-4777 or www.grizzly.com.



grizzly.com[®]

TOOL WEBSITE

Buy Direct and Save with Grizzly[®] – Trusted, Proven and a Great Value!
~Since 1983~

*Visit Our Website Today For
Current Specials!*

**ORDER
24 HOURS A DAY!
1-800-523-4777**



READ THIS FIRST



For questions or help with this product contact Tech Support at (570) 546-9663 or techsupport@grizzly.com

Model G0651/G0652

IMPORTANT UPDATE

For Machines Mfd. Since 10/23
and Owner's Manual Revised 09/10

The following changes were recently made since the owner's manual was printed:

- Parts have changed.

Aside from this information, all other content in the owner's manual applies and **MUST** be read and understood for your own safety. **IMPORTANT: Keep this update with the owner's manual for future reference.**

For questions or help, contact our Tech Support at (570) 546-9663 or techsupport@grizzly.com.

Revised Parts

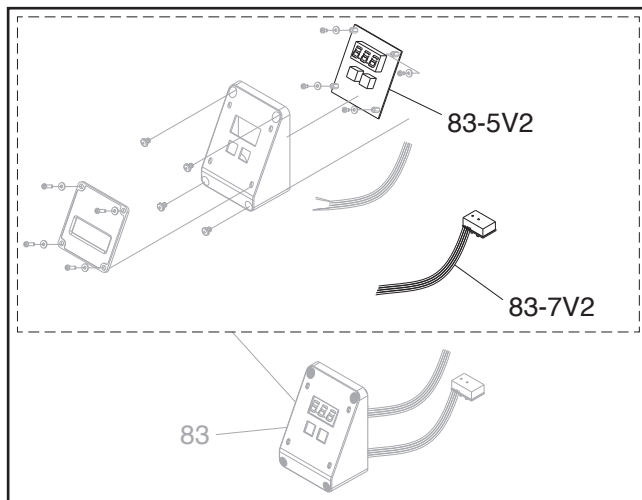

Revised G0651 Parts List

REF	PART #	DESCRIPTION
83-5V2	P0651083-5V2	CIRCUIT BOARD CBEC V2.10.23
83-7V2	P0651083-7V2	DATA CORD 24G 4W 18" V2.10.23

Revised G0652 Parts List

REF	PART #	DESCRIPTION
83-5V2	P0652083-5V2	CIRCUIT BOARD CBEC V2.10.23
83-7V2	P0652083-7V2	DATA CORD 24G 4W 18" V2.10.23



COPYRIGHT © OCTOBER, 2023 BY GRIZZLY INDUSTRIAL, INC.
**WARNING: NO PORTION OF THIS MANUAL MAY BE REPRODUCED IN ANY SHAPE
OR FORM WITHOUT THE WRITTEN APPROVAL OF GRIZZLY INDUSTRIAL, INC.**

#JP22930 PRINTED IN TAIWAN

Motor and Arbor Parts List

REF	PART #	DESCRIPTION
7	PLW04M	LOCK WASHER 8MM
15	PSB40M	CAP SCREW M8-1.25 X 35
16	PB06M	HEX BOLT M8-1.25 X 12
16-1	PW01M	FLAT WASHER 8MM
17V2	P0661042V2	RIVING KNIFE V2.01.10
20	P0651020	STRAIN RELIEF PGA 16-14B
22	PN02M	HEX NUT M10-1.5
23	PLW06M	LOCK WASHER 10MM
24	PW04M	FLAT WASHER 10MM
25	P0651025	SPECIAL MOTOR BOLT
26	PK12M	KEY 5 X 5 X 30
27	P0651027	FLAT BELT 180J-9
28	PSS03M	SET SCREW M6-1 X 8
29	P0651029	PULLEY
30	P6004-2RS	BALL BEARING 6004-2RS
31V2	P0661044V2	CLAMPING BRACKET V2.01.10
31V2-1	P0661044V2-1	MOUNTING BASE V2.01.10
31V2-2	PCAP14M	CAP SCREW M8-1.25 X 20
31V2-3	P0661044V2-4	LOCKING BOLT V2.01.10
31V2-4	P0661044V2-3	COMPRESSION SPRING V2.01.10
31V2-5	P0661044V2-5	MOUNTING PLATE V2.01.10
31V2-6	PSS31M	SET SCREW M5-.8 X 8
31V2-7	PBHS16M	BUTTON HD CAP SCR M5-.8 X 16
31V2-8	P0661044V2-8	HANDLE V2.01.10
31V2-9	PLW01M	LOCK WASHER 5MM
31V2-10	PBHS06M	BUTTON HD CAP SCR M5-.8 X 12
33	PSB11M	CAP SCREW M8-1.25 X 16
35	P0651035	STICK
36	P0651036	BUSHING
37	PK14M	KEY 5 X 5 X 18
38	P0651038	ARBOR SHAFT
39	P0651039	BLADE 10" X 40T
40	P0651040	ARBOR FLANGE
41	P0651041	ARBOR NUT 5/8"-12 RH
42	PSB72M	CAP SCREW M10-1.5 X 30
43	P0651043	TRUNNION SLIDE
44	P0651044	TRUNNION
46	P0651046	DUST CHUTE
47	PS06M	PHLP HD SCR M5-.8 X 20
48	P0651048	MOTOR PULLEY
49	P0651049	BRACKET
50	PB03M	HEX BOLT M8-1.25 X 16
51	PW01M	FLAT WASHER 8MM
52	P0651052	LEADSCREW
53	P0651053	BUSHING
54	P0651054	GASKET
55	P51102	THRUST BEARING 51102
56	P0651056	LEADSCREW BRACKET
57	PSS07M	SET SCREW M5-.8 X 5

REF	PART #	DESCRIPTION
58	P0651058	LEFT BEVEL GEAR
59	PW04M	FLAT WASHER 10MM
60	PLN10M	LOCK NUT M10-1.25
61	P0651061	LEFT SUPPORT
61-1	P0651061-1	RIGHT SUPPORT
62	PN03M	HEX NUT M8-1.25
63	PS14M	PHLP HD SCR M6-1 X 12
64	P0651064	TILT ARROW POINTER
65	PTLW05M	EXT TOOTH WASHER 6MM
66	P0651066	WOODRUFF KEY 5 X 20
67	PSB31M	CAP SCREW M8-1.25 X 25
68	P0651068	HEIGHT HANDWHEEL MTG PLATE
69	P0651069	LOCK KNOB
70	P0651070	HANDWHEEL
71	P0651071	LOCK COLLAR
72	P0651072	FLAT WASHER 19MM
73	P0651073	BLADE HT HANDWHEEL SHAFT
74	P0651074	ALIGNMENT PIN
75	PB20M	HEX BOLT M8-1.25 X 35
76	P0651076	RIGHT BEVEL GEAR
77	PSB06M	CAP SCREW M6-1 X 25
78	PLW03M	LOCK WASHER 6MM
80	P0651080	ON/OFF SWITCH ASSEMBLY
80-1	P0651080-1	ON/OFF PUSH BUTTON SWITCH
80-2	P0651080-2	ON/OFF SWITCH BRACKET
80-3	P0651080-3	ON/OFF SWITCH BOX
80-4	P0651080-4	ON/OFF SWICH CORD 16AWG X 4C
80-6	P0651080-6	SWITCH DISABLING LOCK
81	P0651081	NYLON SCREW 3/16-24 X 1/2
116	P0651116	HANDWHEEL HANDLE
117	PWR810	WRENCH 8 X 10
118	PWR1113	WRENCH 11 X 13
119	PWR1417	WRENCH 14 X 17
120	PAW03M	HEX WRENCH 3MM
121	PAW04M	HEX WRENCH 4MM
122	PAW05M	HEX WRENCH 5MM
123	PAW06M	HEX WRENCH 6MM
124	P0651124	SCREWDRIVER PHLP/FLAT HD #1
130	P0651130	BODY
131	P0651131	DUST CHUTE HOSE 64 X 1000MM
147	P0651147	SPECIAL SCREW
148	P0651148	WAVE WASHER
149	PW04M	FLAT WASHER 10MM
151	P0651151	MOTOR CORD 14AWG X 3C
151	P0652151	MOTOR CORD 14AWG X 4C SJT
152	P0651152	POWER CORD 14AWG X 3C 6-15 PLUG
152	P0652152	PWR CORD 14AWG X 4C SJT W/NO PLUG
153	P0651153	WIRE PROTCTR 16 X 20 X 300MM



Motor and Arbor Parts List Continued

REF PART # DESCRIPTION
G0651 3HP, 220V, SINGLE-PHASE MOTOR

21	P0651021	MOTOR 3HP, 1 PHASE
21-1	P0651021-1	MOTOR FAN COVER
21-2	P0651021-2	MOTOR FAN
21-3	P0651021-3	JUNCTION BOX
21-4	P0651021-4	RUN CAPACITOR COVER
21-5	P0651021-5	R CAP 50M 250V 1-1/2 X 2-3/8
21-6	P0651021-6	S CAP COVER
21-7	P0651021-7	S CAP 300M 125V 1-5/16 X 2-3/8
21-8	P0651021-8	CENTRIFUGAL SWITCH

REF PART # DESCRIPTION
G0652 35P, 220V/440V, THREE-PHASE MOTOR

21	P0652021	MOTOR 5HP, 3 PHASE
21-1	P0652021-1	MOTOR FAN COVER
21-2	P0652021-2	MOTOR FAN
21-3	P0652021-3	JUNCTION BOX

G0651 3HP, 220V, 1-PHASE SWITCH

150	P0651150	MAGNETIC SWITCH 3HP-1PH, 13A
150-1	P0651150-1	MAG SWITCH FRONT COVER
150-2	P0651150-2	MAG SWITCH BACK COVER
150-3	P0651150-3	CONTACTOR SDE MA-18 220V
150-4	P0651150-4	OL RELAY SDE RA-20 12-18

G0652 5HP, 220V/440V, 3-PH SWITCH

150	P0652150	MAGNETIC SWITCH 5HP-3PH, 12A
150-1	P0652150-1	MAG SWITCH FRONT COVER
150-2	P0652150-2	MAG SWITCH BACK COVER
150-3	P0652150-3	CONTACTOR SDE MA-18 220V
150-4	P0652150-4	OL RELAY SDE RA-20 6-12
150-7	P0652150-7	TRANSFORMER
150-8	P0652150-8	FUSE



Cabinet Breakdown

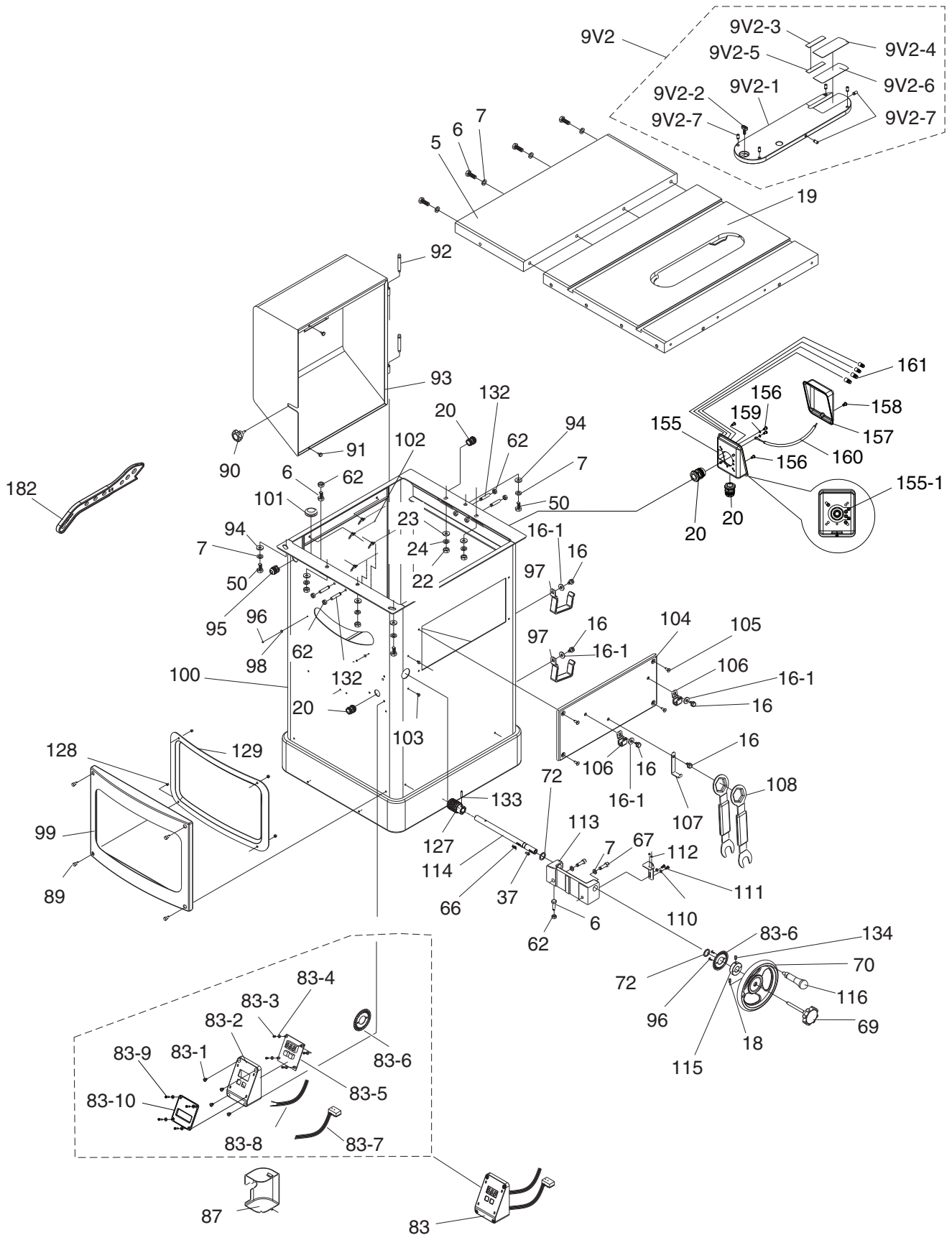

Cabinet Parts List

REF	PART #	DESCRIPTION
5	P0651005	EXTENSION WING
6	PB07M	HEX BOLT M8-1.25 X 25
7	PLW04M	LOCK WASHER 8MM
9V2	P0651009V2	TABLE INSERT ASSY V2.01.10
9V2-1	P0651009V2-1	PLATE V2.01.10
9V2-2	P0661006V2	LOCK KNOB M5-.8 V2.01.10
9V2-3	P0605X1103V2-3	LEFT PLATE V2.01.10
9V2-4	P0651009V2-4	RIGHT PLATE V2.01.10
9V2-5	P0651009V2-5	LEFT TAPE 14MM V2.01.10
9V2-6	P0605X1103V2-6	RIGHT TAPE 35MM V2.01.10
9V2-7	PSS04M	SET SCREW M6-1 X 12
16	PB06M	HEX BOLT M8-1.25 X 12
16-1	PW01M	FLAT WASHER 8MM
17	P0651017	SPLITTER
18	PSS01M	SET SCREW M6-1 X 10
19	P0651019	TABLE
20	P0651020	STRAIN RELIEF PGA 16-14B
22	PN02M	HEX NUT M10-1.5
23	PLW06M	LOCK WASHER 10MM
24	PW04M	FLAT WASHER 10MM
37	PK14M	KEY 5 X 5 X 18
50	PB03M	HEX BOLT M8-1.25 X 16
62	PN03M	HEX NUT M8-1.25
66	PK14M	KEY 5 X 5 X 18
67	PSB31M	CAP SCREW M8-1.25 X 25
69	P0651069	LOCK KNOB
70	P0651070	HANDWHEEL
72	P0651072	FLAT WASHER 19MM
83	P0651083	DIGITAL SENSOR ASSEMBLY
83-1	PS05M	PHLP HD SCR M5-.8 X 8
83-2	P0651083-2	DIGITAL READOUT COVER
83-3	PS79M	PHLP HD SCR M3-.5 X 8
83-4	PW07M	FLAT WASHER 3MM
83-5	P0651083-5	CIRCUIT BOARD
83-6	P0651083-6	SENSOR PLATE
83-7	P0651083-7	DATA CORD 24 AWG X 450
83-8	P0651083-8	DGTL READOUT CRD 18 AWG X 2C
83-9	PS50M	PHLP HD SCR M3-.5 X 12
83-10	P0651083-10	DIGITAL SENSOR COVER
87	P0651087	COVER
89	PSB26M	CAP SCREW M6-1 X 12

REF	PART #	DESCRIPTION
90	P0651090	LOCK KNOB M6-1 X 20
91	P0651091	RUBBER BUMPER
92	P0651092	ALIGNMENT PIN 8 X 54
93	P0651093	MOTOR ACCESS COVER
94	PW01M	FLAT WASHER 8MM
95	P0651095	STRAIN RELIEF PGA 13.5-11B
96	PS17M	PHLP HD SCR M4-.7 X 6
97	P0651097	FENCE MOUNTING BRACKET
98	PW05M	FLAT WASHER 4MM
99	P0651099	FRONT COVER
100	P0651100	CABINET
101	P0651101	STRAIN RELIEF
102	P0651102	CHAIN
103	PHTEK5M	TAP SCREW M4 X 12
104	P0651104	RIGHT COVER
105	PFH06M	FLAT HD SCR M6-1 X 20
106	P0651106	MITER GAUGE MTNG BRACKET
107	P0651107	WRENCH MOUNTING BRACKET
108	P0651108	ARBOR WRENCH
110	PW02M	FLAT WASHER 5MM
111	PB96M	HEX BOLT M5-.8 X 10
112	P0651112	L-PLATE
113	P0651113	BLADE TILT SHAFT BRACKET
114	P0651114	BLADE TILT SHAFT
115	P0651115	SPECIAL RING
116	P0651116	HANDWHEEL HANDLE
127	P0651127	SHAFT
128	PN06M	HEX NUT M5-.8
129	P0651129	PLATE
132	PSS42M	SET SCREW M8-1.25 X 50
133	P0651133	ALIGNMENT PIN 5 X 28
134	PSS16M	SET SCREW M8-1.25 X 10
155	P0651155	JUNCTION BOX BASE
155-1	P0651155-1	GROUNDING LABEL
156	PS09M	PHLP HD SCR M5-.8 X 10
157	P0651157	JUNCTION BOX COVER
158	PS18	PHLP HD SCR 10-24 X 1/4
159	PTLW02M	EXT TOOTH WASHER 5MM
160	P0651160	GROUND WIRE
161	P0651161	WIRE NUT
182	P0661141	PUSH STICK



Blade Guard Breakdown

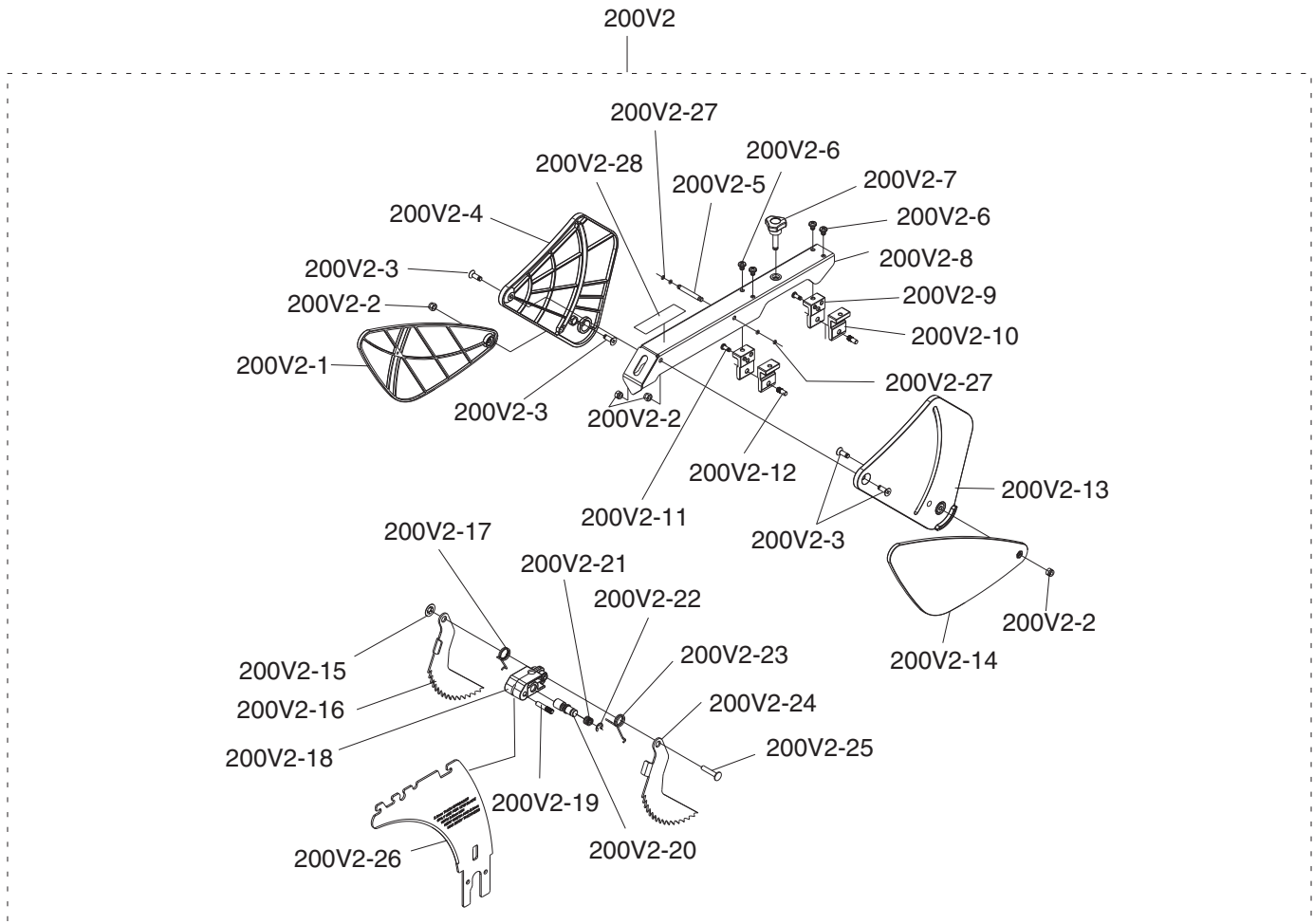

REF	PART #	DESCRIPTION
200V2	P0661002V2	BLADE GUARD ASSY V2.01.10
200V2-1	P0661002V2-1	LEFT PLATE V2.01.10
200V2-2	PLN02M	LOCK NUT M5-.8
200V2-3	PFH01M	FLAT HD SCR M5-.8 X 15
200V2-4	P0661002V2-4	LEFT COVER V2.01.10
200V2-5	P0661002V2-5	ROD CENTER PIN V2.01.10
200V2-6	PS19M	PHLP HD SCR M5-.8 X 6
200V2-7	P0661002V2-7	KNOB BOLT V2.01.10
200V2-8	P0661002V2-8	ROD V2.01.10
200V2-9	P0661002V2-9	LEFT BRACKET V2.01.10
200V2-10	P0661002V2-10	RIGHT BRACKET V2.01.10
200V2-11	PBHS24M	BUTTON HD CAP SCR M4-.7 X 10
200V2-12	P0661002V2-12	MOUNTING PIN V2.01.10
200V2-13	P0661002V2-13	RIGHT COVER V2.01.10
200V2-14	P0661002V2-14	RIGHT PLATE V2.01.10

REF	PART #	DESCRIPTION
200V2-15	P0661002V2-15	PUSH NUT 4MM V2.01.10
200V2-16	P0661002V2-16	LEFT PAWL V2.01.10
200V2-17	P0661002V2-17	RIGHT TORSN SPRING V2.01.10
200V2-18	P0661002V2-18	PAWL MOUNTING BRKT V2.01.10
200V2-19	P0661002V2-19	MOUNTING BRKT PIN V2.01.10
200V2-20	P0661002V2-20	MOUNTING BRKT SHFT V2.01.10
200V2-21	P0661002V2-21	SHAFT SPRING V2.01.10
200V2-22	PEC07M	E-CLIP 7MM
200V2-23	P0661002V2-23	LEFT TORSION SPRING V2.01.10
200V2-24	P0661002V2-24	RIGHT PAWL V2.01.10
200V2-25	P0661002V2-25	RIGHT PAWL SHAFT V2.01.10
200V2-26	P0661002V2-26	SPREADER V2.01.10
200V2-27	PORP003	O-RING 2.8 X 1.9 P3
200V2-28	P0661002V2-28	AMPUTATION HAZ LABEL V2.01.10



Fence Assembly Breakdown

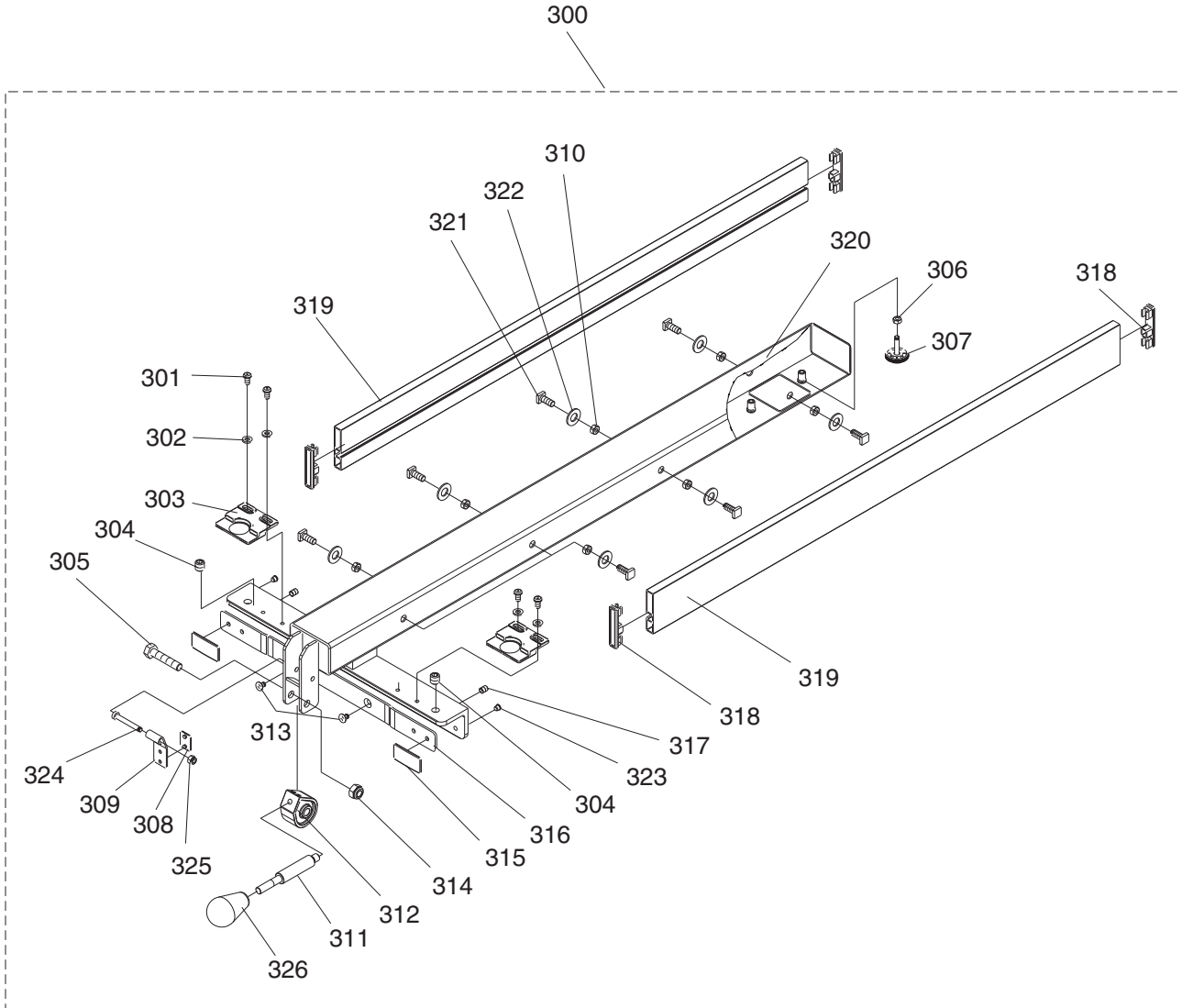

REF	PART #	DESCRIPTION
300	P0651300	FENCE ASSEMBLY
301	PS14M	PHLP HD SCR M6-1 X 12
302	PW03M	FLAT WASHER 6MM
303	P0651303	INDICATOR PLATE
304	P0651304	PLASTIC SET SCREW M12-1.75 X 13
305	PB73M	HEX BOLT M10-1.5 X 50
306	PN01M	HEX NUT M6-1
307	P0651307	REAR RAIL FOOT
308	P0651308	FRONT PLATE
309	P0651309	FRONT BRACKET
310	PN03M	HEX NUT M8-1.25
311	P0651311	FENCE HANDLE SHAFT
312	P0651312	CAM
313	PFH04M	FLAT HD SCR M6-1 X 8

REF	PART #	DESCRIPTION
314	PLN05M	LOCK NUT M10-1.5
315	P0651315	PLASTIC PAD
316	P0651316	CLAMPING BRACKET
317	PSS20M	SET SCREW M8-1.25 X 8
318	P0651318	PLATE CAP
319	P0651319	FENCE PLATE
320	P0651320	FENCE
321	P0651321	T-BOLT M8-1.25 X 20
322	PW01M	FLAT WASHER 8MM
323	P0651323	PLASTIC BUMPER
324	PB71M	HEX BOLT M6-1 X 45
325	PLN03M	LOCK NUT M6-1
326	P0651326	FENCE LOCK HANDLE



Miter Gauge Breakdown

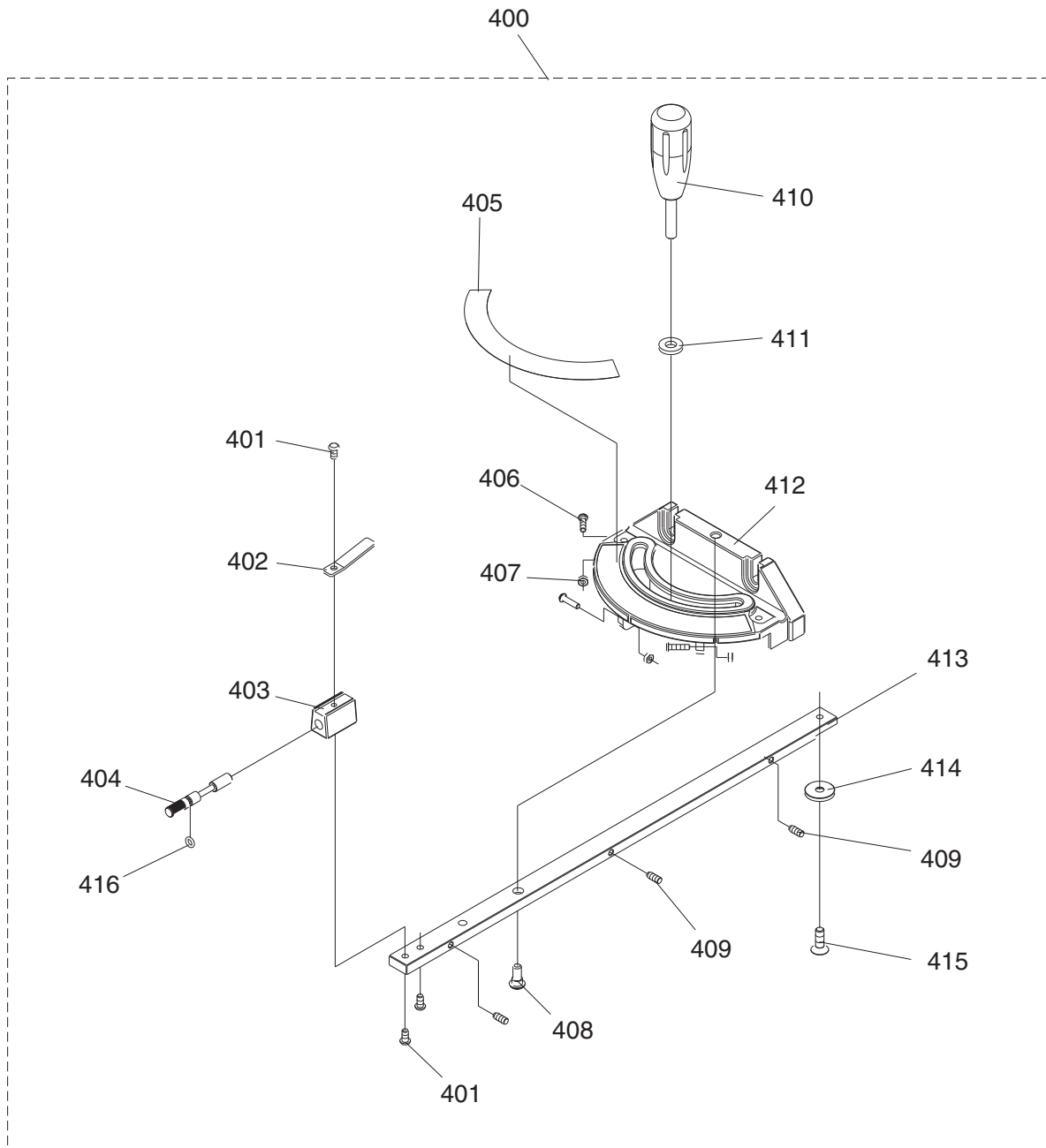

REF	PART #	DESCRIPTION
400	P0651400	MITER GAUGE ASSEMBLY
401	PS06	PHLP HD SCR 10-24 X 3/8
402	P0651402	POINTER
403	P0651403	BLOCK
404	P0651404	SHAFT
405	P0651405	MITER GAUGE SCALE
406	PS25	PHLP HD SCR 8-32 X 5/8
407	PN14	HEX NUT 8-32
408	PS04	PHLP HD SCR 1/4-20 X 1/2

REF	PART #	DESCRIPTION
409	P0651409	SPECIAL SET SCREW M5-.8 X 12
410	P0651410	MITER GAUGE HANDLE
411	PW01M	FLAT WASHER 8MM
412	P0651412	MITER GAUGE
413	P0651413	PLATE
414	P0651414	GUIDE PLATE
415	PFH9M	FLAT HD SCR M6-1 X 6
416	PORP005	O-RING 4.8 X 1.9 P5



Extension Table Breakdown

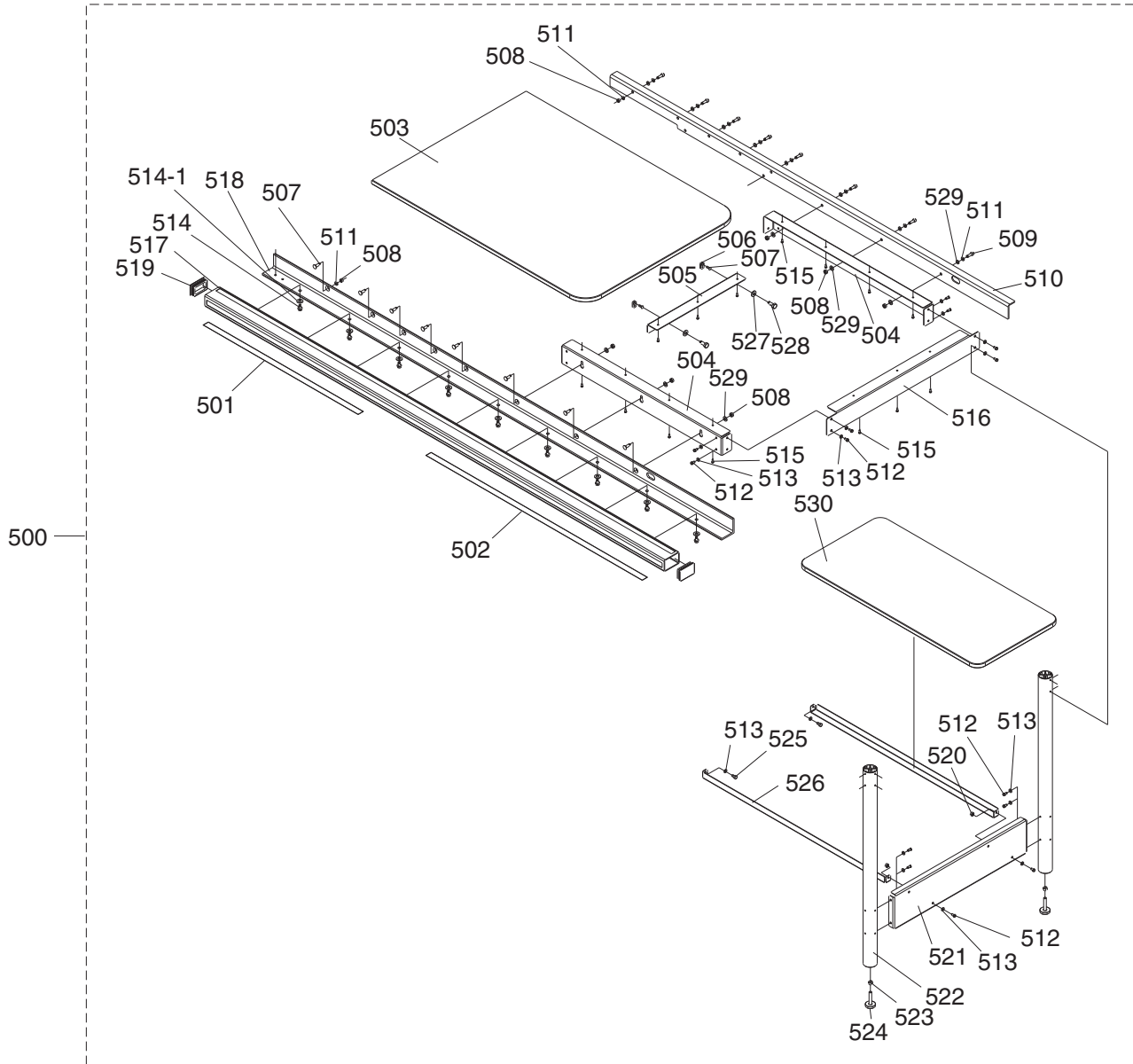

REF	PART #	DESCRIPTION
500	P0651500	EXTENSION TABLE ASSEMBLY
501	P0651501	LEFT SCALE 18"
502	P0651502	RIGHT SCALE 52"
503	P0651503	EXTENSION TABLE PLATE
504	P0651504	EXTENSION TABLE SUPPORT
505	P0651505	FRONT EXTENSION BRACKET
506	P0651506	MOUNTING PLATE
507	PFH21M	FLAT HD SCR M8-1.25 X 25
508	PN03M	HEX NUT M8-1.25
509	PSB31M	CAP SCREW M8-1.25 X 25
510	P0651510	REAR RAIL 79" LONG
511	PLW04M	LOCK WASHER 8MM
512	PS14M	PHLP HD SCR M6-1 X 12
513	PW03M	FLAT WASHER 6MM
514	PB06M	HEX BOLT M8-1.25 X 12
514-1	PW01M	FLAT WASHER 8MM

REF	PART #	DESCRIPTION
515	PHTEK8M	TAP SCREW M4 X 20
516	P0651516	RIGHT EXTENSION BRACKET
517	P0651517	FENCE TUBE (91-1/2" LONG)
518	P0651518	FRONT RAIL (91-1/2" LONG)
519	P0651519	END CAP
520	PN01M	HEX NUT M6-1
521	P0651521	SHELF END PLATE
522	P0651522	SUPPORT LEG
523	PN08	HEX NUT 3/8-16
524	P0651524	FOOT
525	PB02M	HEX BOLT M6-1 X 12
526	P0651526	LOWER SHELF BRACKET
527	PW01M	FLAT WASHER 8MM
528	PB06M	HEX BOLT M8-1.25 X 12
529	PW01M	FLAT WASHER 8MM
530	P0651530	LOWER SHELF



Outfeed Table Breakdown

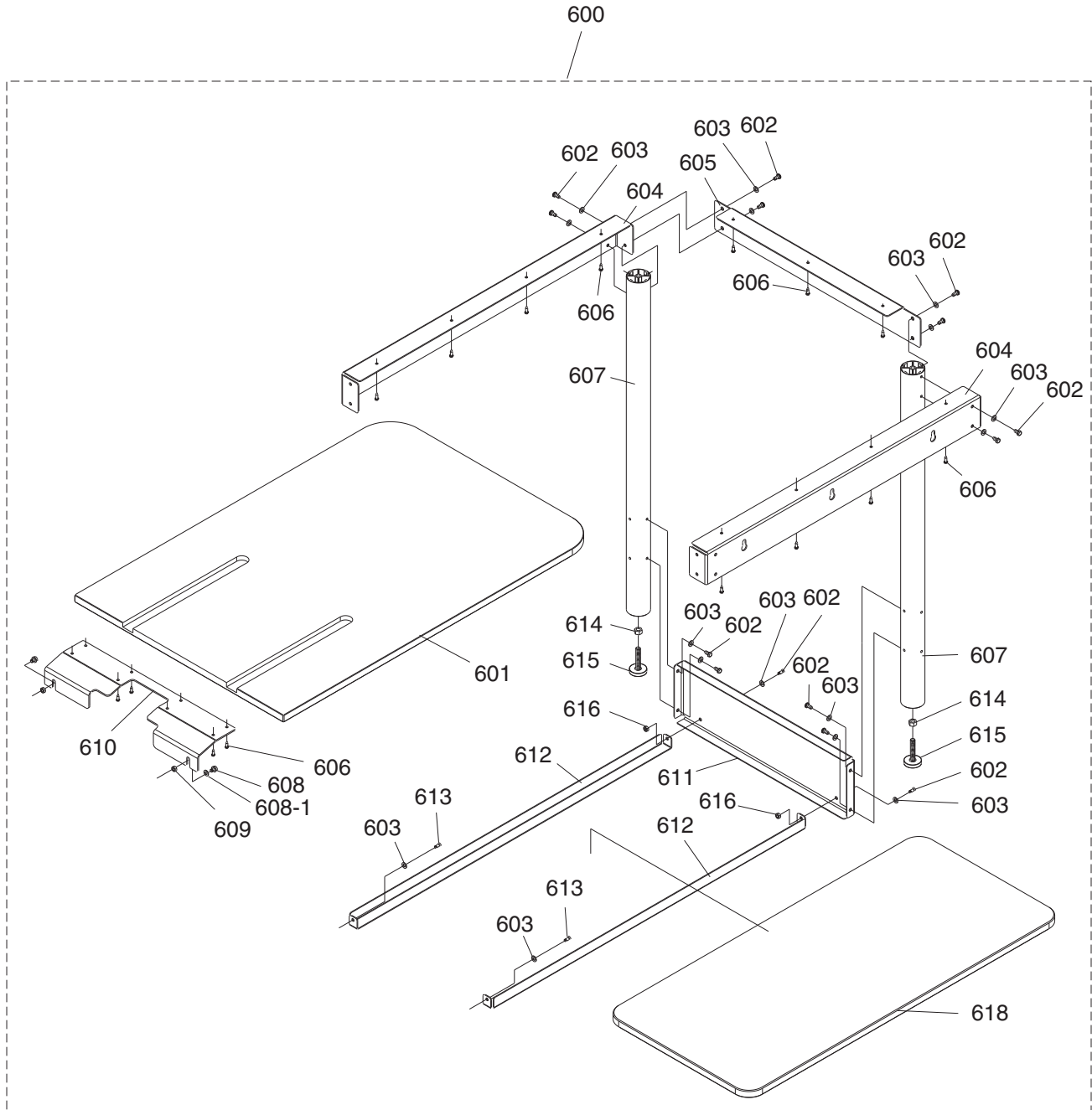

REF	PART #	DESCRIPTION
600	P0651600	OUTFEED TABLE ASSEMBLY
601	P0651601	OUTFEED TABLE PLATE
602	PS14M	PHLP HD SCR M6-1 X 12
603	PW03M	FLAT WASHER 6MM
604	P0651604	OUTFEED TABLE SUPPORT
605	P0651605	OUTFEED TABLE BRACKET
606	PHTEK8M	TAP SCREW M4 X 20
607	P0651607	SUPPORT LEG
608	PB03M	HEX BOLT M8-1.25 X 16
608-1	PW01M	FLAT WASHER 8MM

REF	PART #	DESCRIPTION
609	PN03M	HEX NUT M8-1.25
610	P0651610	FRONT OUTFEED TABLE BRACKET
611	P0651611	SHELF END PLATE
612	P0651612	LOWER SHELF BRACKET
613	PB02M	HEX BOLT M6-1 X 12
614	PN08	HEX NUT 3/8-16
615	P0651615	FOOT
616	PN01M	HEX NUT M6-1
618	P0651618	LOWER SHELF



Label Placement

200V2-28

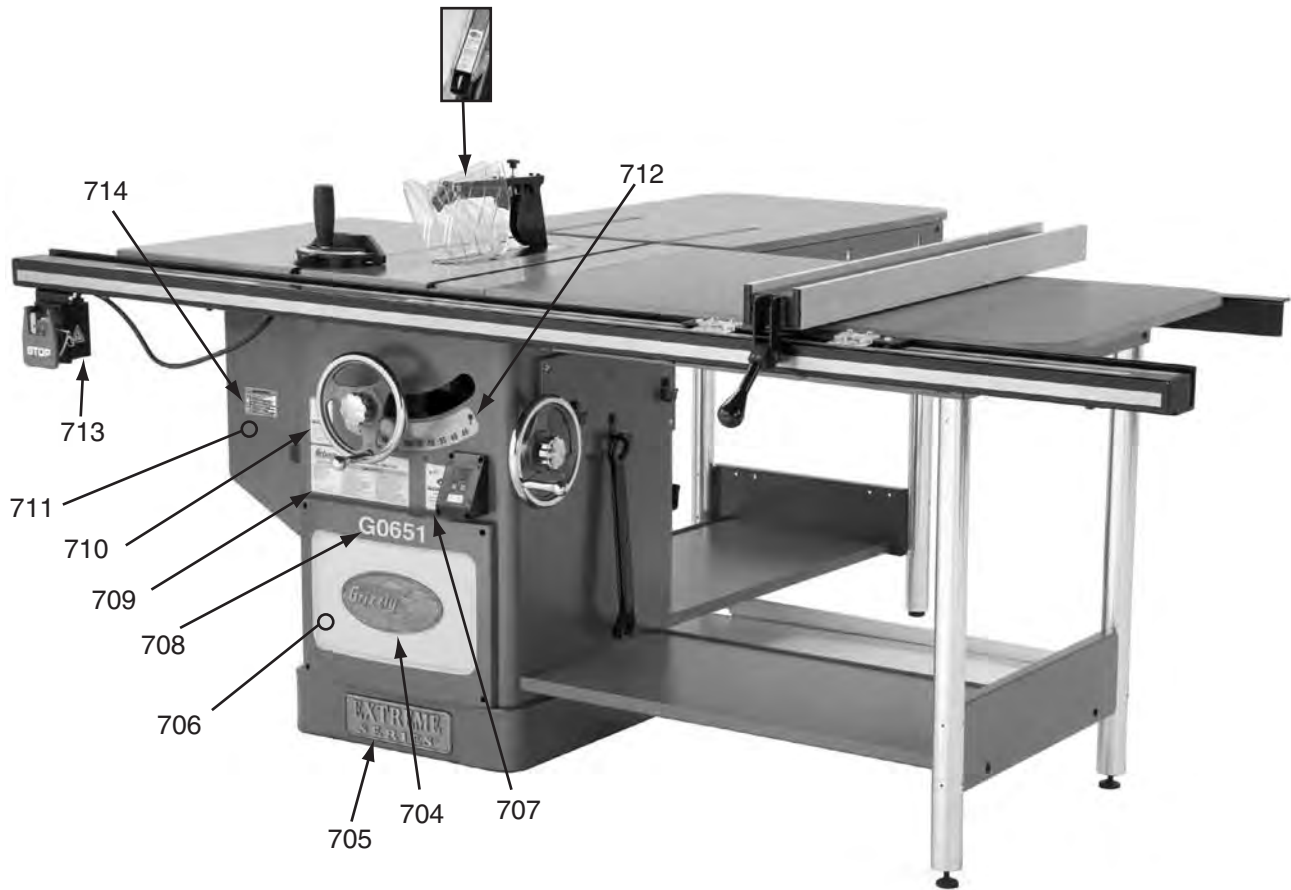

REF	PART #	DESCRIPTION
200V2-28	P0661002V2-28	AMPUTATION HAZ LABEL V2.01.10
704	G8589	GRIZZLY NAMEPLATE-LARGE
705	H7942	EXTREME SERIES PLATE
706	PPAINT-11	PUTTY TOUCH-UP PAINT
707	P0651707	SAFETY GLASSES-HEARING LABEL
708	P0651708	MODEL NUMBER LABEL G0651
708	P0652708	MODEL NUMBER LABEL G0652

REF	PART #	DESCRIPTION
709	P0651709	MACHINE ID LABEL G0651
709	P0652709	MACHINE ID LABEL G0652
710	PLABEL-12A	READ MANUAL-VERTICAL NS 7/05
711	PPAINT-1	GRIZZLY GREEN PAINT
712	P0651712	BLADE TILT ANGLE LABEL
713	PLABEL-14	ELECTRICITY LABEL
714	P0651714	UL 987 WARNING LABEL

WARNING

Safety labels warn about machine hazards and ways to prevent injury. The owner of this machine **MUST** maintain the original location and readability of the labels on the machine. If any label is removed or becomes unreadable, **REPLACE** that label before using the machine again. Contact Grizzly at (800) 523-4777 or www.grizzly.com to order new labels.

