

Grizzly **Industrial, Inc.**®

MODEL H7760 COMBINATION 2" x 27" BELT SANDER & 6" GRINDER OWNER'S MANUAL



COPYRIGHT © NOVEMBER, 2005 BY GRIZZLY INDUSTRIAL, INC.
**WARNING: NO PORTION OF THIS MANUAL MAY BE REPRODUCED IN ANY SHAPE
OR FORM WITHOUT THE WRITTEN APPROVAL OF GRIZZLY INDUSTRIAL, INC.**
#JK7691 PRINTED IN CHINA



WARNING!

Some dust created by power sanding, sawing, grinding, drilling, and other construction activities contains chemicals known to the State of California to cause cancer, birth defects or other reproductive harm. Some examples of these chemical are:

- Lead from lead-based paints.
- Crystalline silica from bricks, cement and other masonry products.
- Arsenic and chromium from chemically-treated lumber.

Your risk from these exposures varies, depending on how often you do this type of work. To reduce your exposure to these chemicals: Work in a well ventilated area, and work with approved safety equipment, such as those dust masks that are specially designed to filter out microscopic particles.

WARNING

Safety labels warn about machine hazards and ways to prevent injury. The owner of this machine **MUST** maintain the original location and readability of the labels on the machine. If any label is removed or becomes unreadable, **REPLACE** that label before using the machine again. Contact Grizzly at (800) 523-4777 or www.grizzly.com to order new labels.

Table of Contents

INTRODUCTION	2
Foreword	2
Contact Info	2
Machine Data Sheet.....	3
IDENTIFICATION	4
SECTION 1: SAFETY	5
Safety Instructions for Machinery.....	5
Additional Safety Instructions for Grinders.....	7
Additional Safety Instructions for Sanders	8
SECTION 2: CIRCUIT REQUIREMENTS	9
110V Operation	9
SECTION 3: SET UP	10
Unpacking	10
Inventory.....	10
Mounting.....	11
Tool Rests	12
Spark Guard & Eye Shield	12
Belt Tracking	13
Dust Port	13
SECTION 4: OPERATION	14
Test Run.....	14
Before Grinding	15
Operating Grinder	15
Wheel Care	16
Wheel Dressing	16
Wheel Selection	17
Wheel Inspection.....	17
Replacing Wheels	18
Sanding	19
Replacing Belts	20
SECTION 5: ACCESSORIES	21
SECTION 6: MAINTENANCE	22
General.....	22
Lubrication.....	22
Grinding Wheels.....	22
Sanding Belts	22
SECTION 7: SERVICE	23
Troubleshooting.....	23
Parts Breakdown	25
Parts List	26
WARRANTY AND RETURNS	27

INTRODUCTION

Foreword

We are proud to offer the Model H7760 Combination 2" x 27" Belt Sander & 6" Grinder. This machine is part of a growing Grizzly family of fine machinery. When used according to the guidelines set forth in this manual, you can expect years of trouble-free, enjoyable operation and proof of Grizzly's commitment to customer satisfaction.

We are pleased to provide this manual with the Model H7760. It was written to guide you through assembly, review safety considerations, and cover general operating procedures. It represents our effort to produce the best documentation possible.

The specifications, drawings, and photographs illustrated in this manual represent the Model H7760 as supplied when the manual was prepared. However, owing to Grizzly's policy of continuous improvement, changes may be made at any time with no obligation on the part of Grizzly. For your convenience, we always keep current Grizzly manuals available on our website at **www.grizzly.com**. Any updates to your machine will be reflected in these manuals as soon as they are complete. Visit our site often to check for the latest updates to this manual!

Contact Info

If you have any comments regarding this manual, please write to us at the address below:

Grizzly Industrial, Inc.
c/o Technical Documentation Manager
P.O. Box 2069
Bellingham, WA 98227-2069

We stand behind our machines. If you have any service questions or parts requests, please call or write us at the location listed below.

Grizzly Industrial, Inc.
1203 Lycoming Mall Circle
Muncy, PA 17756
Phone: (570) 546-9663
Fax: (800) 438-5901
E-Mail: techsupport@grizzly.com
Web Site: <http://www.grizzly.com>





MACHINE DATA SHEET

Customer Service #: (570) 546-9663 • To Order Call: (800) 523-4777 • Fax #: (800) 438-5901

MODEL H7760 GRINDER/SANDER COMBO

Design Type Bench Model

Overall Dimensions:

Height (w/Work Light Extended)..... 19³/₄"
 Width 15¹/₄"
 Depth 11³/₄"
 Shipping Weight 26 lbs.
 Net Weight..... 22 lbs.
 Box Size 17¹/₂" L x 15¹/₂" W x 9⁵/₈" H
 Footprint 5" x 6"
 Arbor..... 1/2"
 Wheel Size 6" x 3/4"
 Sanding Belt Size 2" x 27"

Motor:

Type..... TEFC Capacitor-Start Induction
 Horsepower 1/2 HP
 Voltage/Phase 110V / Single-Phase
 Amps 3.2A
 Cycle / RPM 60 Hertz / 3450 RPM
 Bearings Shielded & Permanently Lubricated

Features:

..... Wheel Flanges
 Tool Rests
 Rocker-Type Switch
 Extended Wheel-to-Motor Clearance
 Convenient Coolant Tray
 Included 80 Grit Sanding Belt
 Included Aluminum Oxide 36 Grit Grinding Wheel

Specifications, while deemed accurate, are not guaranteed.



IDENTIFICATION

To help you understand the Model H7760 set up and operation instructions, match the list below with the letters in **Figures 1 & 2**.

- A. Wheel Dressing Tool
- B. Work Light
- C. Eye Shield
- D. Grinding Wheel
- E. Grinding Wheel Tool Rest
- F. Coolant Tray
- G. ON/OFF Switch
- H. Sanding Belt Tool Rest
- I. Sanding Belt
- J. Dust Port
- K. Power Plug
- L. Sanding Belt Tension Knob
- M. Sanding Belt Tracking Knob
- N. Spark Guard

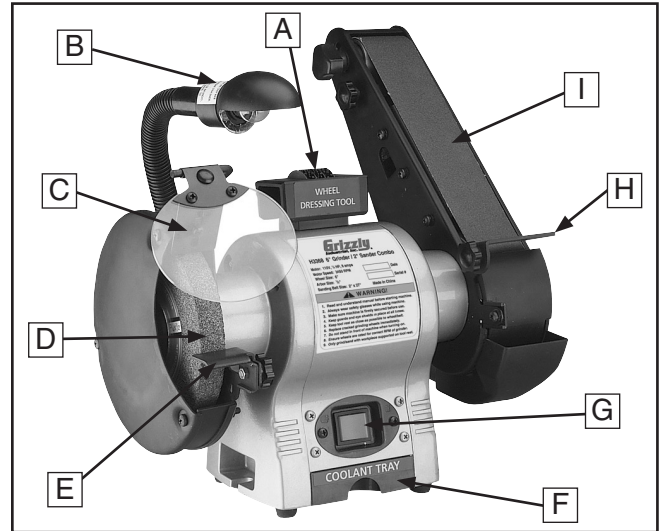

Figure 1. H7760 front view.

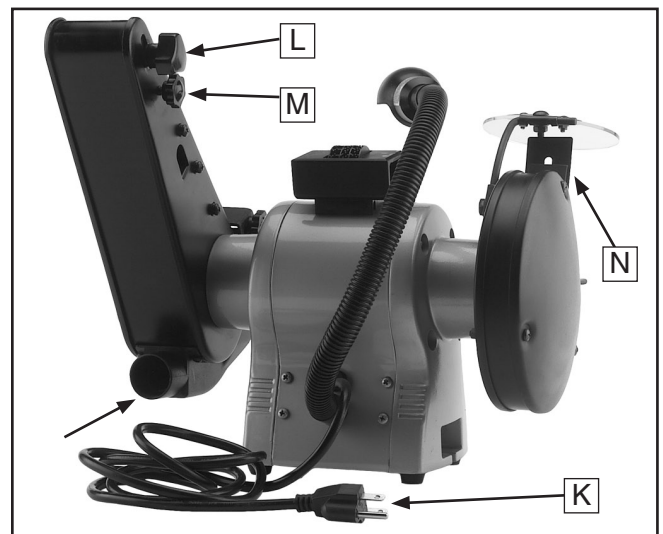

Figure 2. H7760 rear view.



SECTION 1: SAFETY

WARNING

For Your Own Safety, Read Instruction Manual Before Operating this Machine

The purpose of safety symbols is to attract your attention to possible hazardous conditions. This manual uses a series of symbols and signal words which are intended to convey the level of importance of the safety messages. The progression of symbols is described below. Remember that safety messages by themselves do not eliminate danger and are not a substitute for proper accident prevention measures.

 **DANGER** Indicates an imminently hazardous situation which, if not avoided, WILL result in death or serious injury.

 **WARNING** Indicates a potentially hazardous situation which, if not avoided, COULD result in death or serious injury.

 **CAUTION** Indicates a potentially hazardous situation which, if not avoided, MAY result in minor or moderate injury. It may also be used to alert against unsafe practices.

NOTICE This symbol is used to alert the user to useful information about proper operation of the machine.

WARNING

Safety Instructions for Machinery

- 1. READ THROUGH THE ENTIRE MANUAL BEFORE STARTING MACHINERY.** Machinery presents serious injury hazards to untrained users.
- 2. ALWAYS USE ANSI APPROVED SAFETY GLASSES WHEN OPERATING MACHINERY.** Everyday eyeglasses only have impact resistant lenses. They are NOT safety glasses.
- 3. ALWAYS WEAR AN ANSI APPROVED RESPIRATOR WHEN OPERATING MACHINERY THAT PRODUCES DUST.** Wood dust is a carcinogen and can cause cancer and severe respiratory illnesses.
- 4. ALWAYS USE HEARING PROTECTION WHEN OPERATING MACHINERY.** Machinery noise can cause permanent hearing damage.
- 5. WEAR PROPER APPAREL. DO NOT** wear loose clothing, gloves, neckties, rings, or jewelry which may get caught in moving parts. Wear protective hair covering to contain long hair and wear non-slip footwear.
- 6. NEVER OPERATE MACHINERY WHEN TIRED, OR UNDER THE INFLUENCE OF DRUGS OR ALCOHOL.** Be mentally alert at all times when running machinery.



WARNING

Safety Instructions for Machinery

7. **ONLY ALLOW TRAINED AND PROPERLY SUPERVISED PERSONNEL TO OPERATE MACHINERY.** Make sure operation instructions are safe and clearly understood.
8. **KEEP CHILDREN AND VISITORS AWAY.** Keep all children and visitors a safe distance from the work area.
9. **MAKE WORKSHOP CHILD PROOF.** Use padlocks, master switches, and remove start switch keys.
10. **NEVER LEAVE WHEN MACHINE IS RUNNING.** Turn power off and allow all moving parts to come to a complete stop before leaving machine unattended.
11. **DO NOT USE IN DANGEROUS ENVIRONMENTS.** DO NOT use machinery in damp, wet locations, or where any flammable or noxious fumes may exist.
12. **KEEP WORK AREA CLEAN AND WELL LIT.** Clutter and dark shadows may cause accidents.
13. **USE A GROUNDED EXTENSION CORD RATED FOR THE MACHINE AMPERAGE.** Undersized cords overheat and lose power. Replace extension cords if they become damaged. DO NOT use extension cords for 220V machinery.
14. **ALWAYS DISCONNECT FROM POWER SOURCE BEFORE SERVICING MACHINERY.** Make sure switch is in OFF position before reconnecting.
15. **MAINTAIN MACHINERY WITH CARE.** Keep blades sharp and clean for best and safest performance. Follow instructions for lubricating and changing accessories.
16. **MAKE SURE GUARDS ARE IN PLACE AND WORK CORRECTLY BEFORE USING MACHINERY.**
17. **REMOVE ADJUSTING KEYS AND WRENCHES.** Make a habit of checking for keys and adjusting wrenches before turning machinery **ON**.
18. **CHECK FOR DAMAGED PARTS BEFORE USING MACHINERY.** Check for binding and alignment of parts, broken parts, part mounting, loose bolts, and any other conditions that may affect machine operation. Repair or replace damaged parts.
19. **USE RECOMMENDED ACCESSORIES.** Refer to the instruction manual for recommended accessories. The use of improper accessories may cause risk of injury.
20. **DO NOT FORCE MACHINERY.** Work at the speed for which the machine or accessory was designed.
21. **SECURE WORKPIECE.** Use clamps or a vise to hold the workpiece when practical. A secured workpiece protects your hands and frees both hands to operate the machine.
22. **DO NOT OVERREACH.** Keep proper footing and balance at all times.
23. **MANY MACHINES WILL EJECT THE WORKPIECE TOWARD THE OPERATOR.** Know and avoid conditions that cause the workpiece to "kickback."
24. **ALWAYS LOCK MOBILE BASES (IF USED) BEFORE OPERATING MACHINERY.**
25. **BE AWARE THAT CERTAIN MATERIALS MAY CAUSE AN ALLERGIC REACTION** in people and animals, especially when exposed to fine dust. Make sure you know what type of dust you will be exposed to and always wear an approved respirator.



WARNING

Additional Safety Instructions for Grinders

- 1. EYE PROTECTION.** Grinding causes small particles to become airborne at a high rate of speed. ALWAYS wear safety glasses when using this machine.
- 2. MOUNTING TO BENCH/STAND.** An unsecured grinder may become dangerously out of control during operation. Make sure grinder is FIRMLY secured to a bench or stand before use.
- 3. WHEEL SPEED RATING.** Wheels operated faster than the rated RPM may break or fly apart. Before mounting a new wheel, be sure the wheel RPM rating is equal or higher than the speed of the grinder.
- 4. WHEEL FLANGES.** Only use the flanges included with the grinder when mounting wheels. Other flanges may not properly secure the wheel and cause an accident.
- 5. RING TEST.** Perform a "ring test" on grinding wheels before installation to ensure that they are safe to use. A wheel that does not pass the ring test may break or fly apart during operation. See **Page 17** for details on how to perform a ring test.
- 6. STARTING GRINDER.** If a wheel is damaged, it will usually fly apart shortly after start-up. To protect yourself, always stand to the side of the grinder when turning it **ON** and allow it to gain full speed before standing in front of it.
- 7. LUNG PROTECTION.** Grinding produces hazardous dust, which may cause long-term respiratory problems. Always wear a NIOSH approved dust mask or respirator when grinding.
- 8. SIDE GRINDING.** Grinding on the side of wheels can cause the them to break and fly apart unless the wheel is rated for side grinding.
- 9. TOP GRINDING.** Grinding on the top of wheels greatly increases the risk of workpiece kickback. Always grind on the downward part of the wheel.
- 10. HAND/WHEEL CONTACT.** Grinding wheels have the capability of removing a lot of skin fast. Keep a firm grip on the workpiece and position your hands a safe distance away when grinding. Avoid wearing gloves as they may get caught in the grinding wheel and cause even more serious entanglement injuries.
- 11. TOOL REST POSITION.** If the tool rest is too far away from the wheel, the workpiece may be pulled down, causing loss of control and pulling your hand into the grinding wheel. Keep the tool rest within $\frac{1}{8}$ " of the wheel when operating.
- 12. EYE SHIELD POSITION.** Hot sparks from grinding can cause serious eye and skin damage. Always ensure the eye shield is in place and properly angled so that you are protected. If the eye shield is damaged, replace it immediately!
- 13. CRACKED WHEEL.** Cracked wheels may break and fly apart during operation. Replace cracked wheels immediately!



WARNING

Additional Safety Instructions for Sanders

- 1. RESPIRATOR AND SAFETY GLASSES.** Always wear a respirator and safety glasses while operating the machine. Dust and chips are created when sanding. Some debris will be ejected, becoming hazards to the eyes and lungs.
- 2. DUST COLLECTION SYSTEM.** Never operate the sander without an adequate dust collection system in place and running.
- 3. CLOTHING.** DO NOT wear loose clothing while operating this machine. Roll up or button sleeves at the cuff.
- 4. HAND PROTECTION.** DO NOT place hands near, or in contact with, sanding belt during operation. DO NOT allow fingers to get pinched between the workpiece and the table. This may pull the operator's hand into the machine and cause serious injury!
- 5. MINIMUM STOCK DIMENSIONS.** Do not sand any stock thinner than $\frac{1}{16}$ ", narrower than $\frac{1}{8}$ ", or shorter than 9".
- 6. INSPECTING WORKPIECES.** Always inspect workpiece for nails, staples, knots, and other imperfections that could be dislodged and thrown from the machine during sanding operations.
- 7. SANDING METAL.** DO NOT sand any kind of metal, as this is an imminent fire hazard and could lead to serious injury or death.
- 7. FEEDING WORKPIECE.** Firmly grasp the workpiece in both hands and ease it into the machine using light pressure. DO NOT jam the workpiece into the machine during operation. Feed the workpiece against the direction of rotation. DO NOT sand tapered or pointed stock with the point facing the feed direction. Never sand more than one piece of stock at a time.
- 8. UNATTENDED OPERATION.** Never leave the machine running unattended.
- 9. REPLACING SANDPAPER.** Replace sanding paper when it becomes worn. DO NOT operate the sander with damaged or badly worn sandpaper.
- 10. MAINTENANCE AND ADJUSTMENTS.** Perform machine inspections and maintenance service promptly when called for. Disconnect power before performing maintenance or adjustments on the sander.
- 11. EXPERIENCING DIFFICULTIES.** Any problem, with the exception of conveyor or belt tracking that is concerned with any moving parts or accessories, must be investigated and corrected with the power disconnected, and after all moving parts have come to a complete stop.

WARNING

Like all machines there is danger associated with the Model H7760. Accidents are frequently caused by lack of familiarity or failure to pay attention. Use this machine with respect and caution to lessen the possibility of operator injury. If normal safety precautions are overlooked or ignored, serious personal injury may occur.

CAUTION

No list of safety guidelines can be complete. Every shop environment is different. Always consider safety first, as it applies to your individual working conditions. Use this and other machinery with caution and respect. Failure to do so could result in serious personal injury, damage to equipment, or poor work results.



SECTION 2: CIRCUIT REQUIREMENTS

110V Operation

⚠️ WARNING

Serious personal injury could occur if you connect the machine to the power source before you have completed the set up process. **DO NOT** connect the machine to the power source until instructed to do so.

Amperage Draw

The Model H7760 motor draws the following amps under maximum load:

Motor Draw3.2 Amps

Circuit Recommendations

We recommend connecting this machine to a dedicated circuit with a verified ground (**Figure 3**), using the circuit breaker size given below. Never replace a circuit breaker with one of higher amperage without consulting a qualified electrician. **If you are unsure about the wiring codes in your area or you plan to connect your machine to a shared circuit, you may create a fire hazard—consult a qualified electrician to reduce this risk.**

Circuit Breaker..... 10 Amps

Plug/Receptacle Type

Included Plug Type..... NEMA 5-15

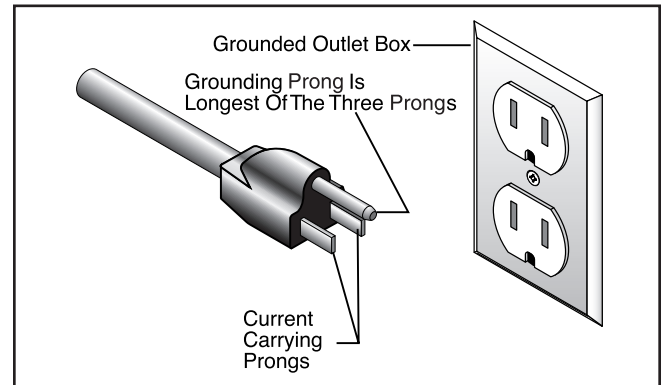
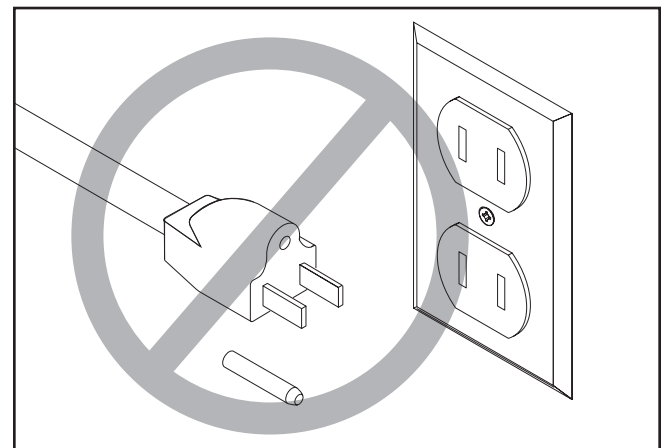
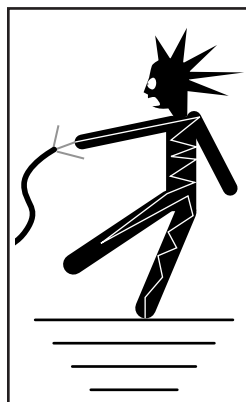

Figure 3. Typical type 5-15 plug & receptacle.



⚠️ CAUTION

This machine must have a ground prong in the plug to help ensure that it is grounded. **DO NOT** remove ground prong from plug to fit into a two-pronged outlet! If the plug will not fit the outlet, have the proper outlet installed by a qualified electrician.



⚠️ WARNING

Electrocution or fire could result if this machine is not grounded correctly or if your electrical configuration does not comply with local and state codes. **Ensure compliance by checking with a qualified electrician!**

Extension Cords

We do not recommend the use of extension cords. If you find it absolutely necessary:

- Use at least a 16 gauge cord that does not exceed 50 feet in length!
- The extension cord must also contain a ground wire and plug pin.
- A qualified electrician **MUST** size cords over 50 feet long to prevent motor damage.



SECTION 3: SET UP

Unpacking



CAUTION
Some metal parts may have sharp edges on them after they are formed. Please examine the edges of all metal parts before handling them. Failure to do so could result in injury.

The Model H7760 is shipped from the manufacturer in a carefully packed carton. If you discover the machine is damaged after you have signed for delivery, *please immediately call Customer Service at (570) 546-9663 for advice.*

Save the containers and all packing materials for possible inspection by the carrier or its agent. *Otherwise, filing a freight claim can be difficult.*

When you are completely satisfied with the condition of your shipment, you should inventory the contents.

NOTICE

A full parts list and breakdown can be found toward the end of this manual. For easier assembly, or to identify specific parts, please refer to the detailed illustrations at the end of the manual.

Inventory

After all the parts have been removed from the carton, you should have the parts shown in Figure 4:

Inventory	Qty
A. Spark Guard	1
B. Wheel Dressing Tool	1
C. Eye Shield & Bracket	1
D. Tool Rests	2
E. Grinder/Sander Unit	1
F. Hardware Bag	1
—Knob Bolt M5-0.8	2
—Flat Washer 5mm	2
—Hex Nut M5-0.8	2
—Flat Washer 8mm	1
—Hex Bolt M8-1.25	1
—Support Arm Bracket	1

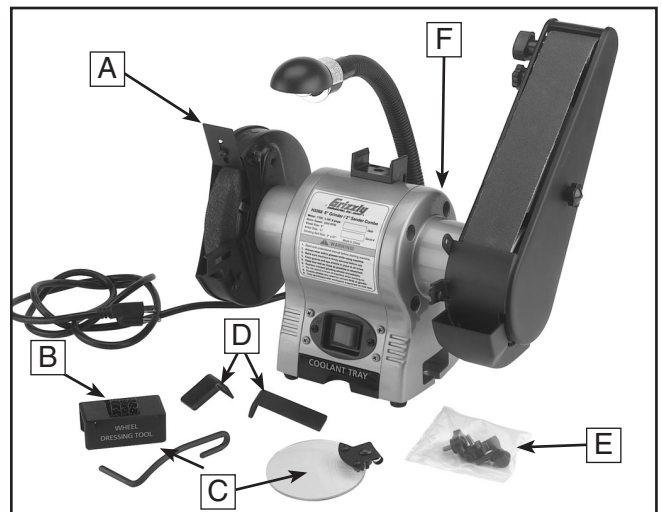

Figure 4. Model H7760 inventory.



Items Needed for Set Up

The following items are needed to complete the set up process, but are not included with your machine:

Description	Qty
Wrench 8mm	1
Wrench 13mm	1
Hex Bolt M8-1.25 (length varies).....	2
Flat Washer 8mm	4
Lock Washer 8mm	2
Hex Nut M8-1.25	2

Mounting

The Model H7760 weighs 22 lbs. Make sure the workbench on which you plan to mount the grinder is sturdy enough to hold the weight of the machine and any downward pressure that may be applied during operation. The workbench should have a level surface and be heavy, or attached to the floor so that it will not move during operation.

Components and Hardware Required	Qty
Sander/Grinder Unit	1
Hex Bolt M8-1.25 (length varies).....	2
Flat Washer 8mm	4
Lock Washer 8mm	2
Hex Nut M8-1.25	2

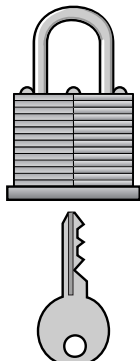

CAUTION

The Model H7760 can cause personal injury if operated by untrained users. Ensure that your machine is inaccessible to children and visitors by closing and locking all entrances to your shop/garage when you are away.

NOTICE

When mounted, the cooling tray can be easily damaged if the grinder is tipped forward.

To mount the grinder:

1. Find the best place in your shop to mount the grinder/sander.

—Pick a spot on the workbench that will allow enough room to move the size of an anticipated workpiece around the grinder. The operator (and possibly bystanders) should have enough room to stand out of the way.

—Mount the grinder in an area with proper lighting and near electrical outlets. Lighting should be bright enough to eliminate shadow and prevent eye strain. Electrical circuits should be dedicated or large enough to handle amperage requirements.

Note: Keep power or extension cords clear of high-traffic areas. If you install new lighting, outlets, or circuits, observe all electrical codes.

2. Mount the grinder to the workbench with bolts that are long enough to exceed the thickness of your workbench and the grinder base. Secure each bolt with flat washers, a lock washer, and a hex nut as illustrated in **Figure 5**.

Note: Because sizes vary for each individual situation, the hardware in this step is not included with the Model H7760.

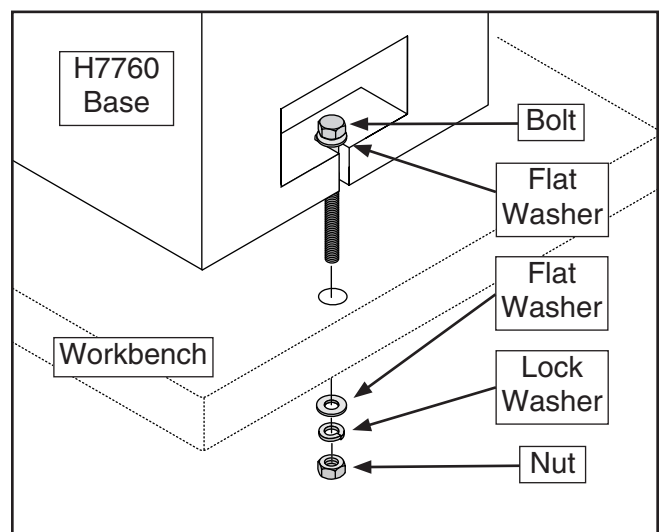

Figure 5. Mounting machine to the workbench.



Tool Rests

The tool rest attaches to the inward side of the guard and provides a surface that must be used to support the workpiece during operation. Certain types of grinding/sanding may require jigs or accessories that will be used with the tool rests to assure the proper angle of the workpiece against the wheel. Failure to install and use the tool rest can lead to serious personal injury!

Components and Hardware Required	Qty
Knob Bolt M5-0.8.....	2
Flat Washer 5mm.....	2
Hex Nut M5-0.8.....	2

To install the tool rests:

1. Loosely attach the tool rests perpendicular to the belt or wheel surface with the knob bolts and 5mm washers and hex nuts.
2. To adjust the angle of the sanding belt tool rest, use a square or a protractor to set the angle of the tool rest in relation to the sanding belt.
3. Adjust both tool rests approximately $\frac{1}{16}$ "- $\frac{1}{8}$ " from the grinding wheel and the sanding belt and tighten the knob bolts. **Figure 6** shows the correct adjustment for the tool rest at the grinding wheel.



Figure 6. Tool rest installed and positioned near the grinding wheel.

Spark Guard & Eye Shield

The spark guard must be installed and positioned $\frac{1}{8}$ " from the grinding wheel to minimize sparks flying towards the operator. The eye shield must be positioned between the grinding wheel and the operator's face to protect the operator from flying debris—this is not a replacement for safety glasses!

Components and Hardware Required	Qty
Eye Shield & Bracket	1
Eye Shield Support Arm.....	1
Support Arm Bracket.....	1
Spark Guard.....	1
Flat Washer 8mm.....	1
Hex Bolt M8-1.25.....	1
Carriage Bolt M6-1.0 x 18.....	1
Flat Washer 6mm.....	1
Hex Nut M6-1.0.....	1
Phillips Head Screw M5-0.8 x 8.....	1
Flat Washer 5mm.....	1

To install the spark guard and eye shield:

1. Using the included 5mm screw and washer, install the spark guard as shown in **Figure**

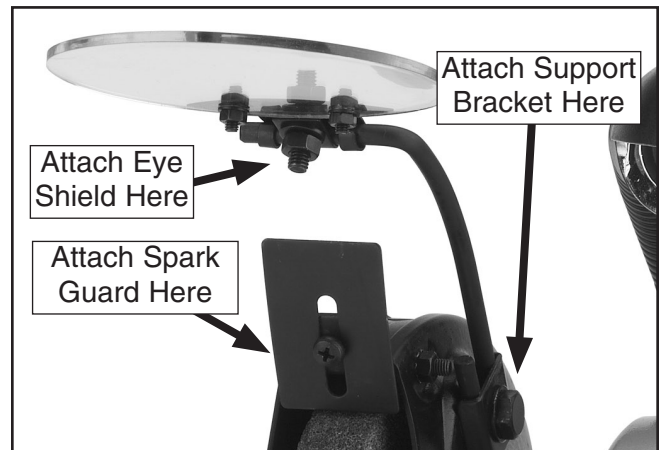

Figure 7. Spark guard and eye shield attached.

- 7.
2. Attach the eye shield to the support bracket with the included 6mm carriage bolt, washer and hex nut. Use the 8mm hex bolt and washer to attach the support bracket to the



Belt Tracking

“Tracking” the sanding belt means to center the belt on its rollers, so that it runs balanced and does not make contact with the sides of the belt cover.

To track the sanding belt:

1. DISCONNECT THE MACHINE FROM THE POWER SUPPLY!
2. Rotate the grinding wheel.
3. As you rotate the grinding wheel, watch how the sanding belt rides on the upper roller. If the belt is tracking properly, the sanding belt should be centered between the sides of the belt cover as shown in **Figure 8**.



Figure 8. Sanding belt centered between belt cover edges at the upper roller.

5. While spinning the wheel, turn the tracking control knob (**Figure 9**) counterclockwise to make the belt move to the left, or turn the tracking control knob clockwise to make the belt move to the right.

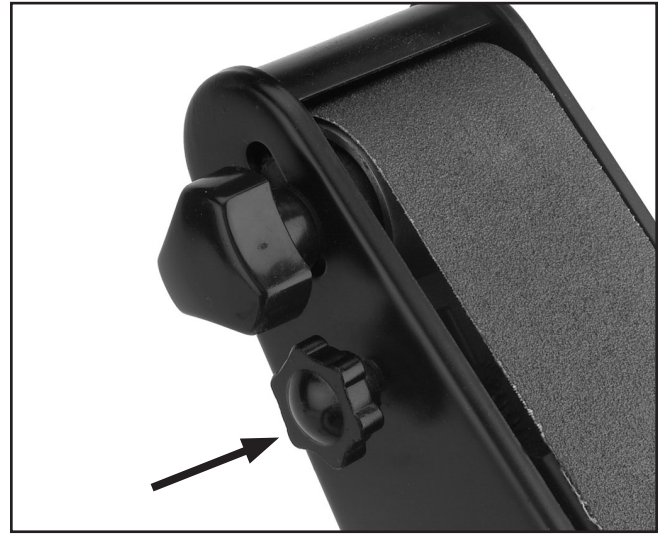

Figure 9. Tracking control knob.

6. After the belt is centered, spin the grinding wheel approximately ten times to ensure that the belt continues to track properly.

Dust Port

The dust port is located behind the sanding belt, below the belt roller. The opening is 1½" in diameter and can be connected to a utility vacuum (such as a SHOP•VAC®) or a dust collector.

To connect the dust port to a dust collection system:

1. Place a hose clamp over the dust hose.
2. Slide the hose over the dust port.
3. Secure the hose airtight with the hose clamp.
4. Check the hose with a light tug to ensure it is secure.



SECTION 4: OPERATION

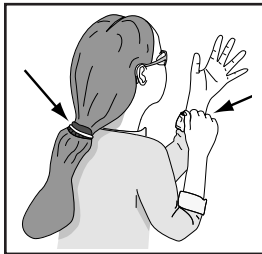

!WARNING

Keep loose clothing rolled up and out of the way of machinery and keep hair pulled back.

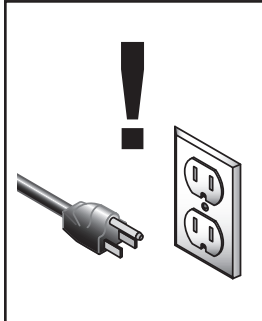

!WARNING

Disconnect power from the machine when performing any maintenance, assembly or adjustments. Failure to do this may result in serious personal injury.

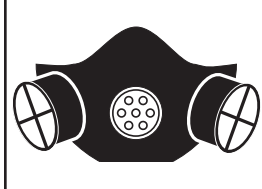
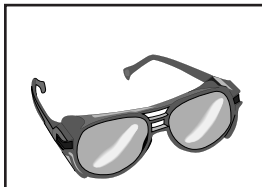

!WARNING

Using this machine produces dust which may cause allergic reactions and respiratory problems. Protect yourself by wearing safety glasses and a respirator during the entire operation process. **DO NOT** wear gloves while operating this machine as they can be caught in the rotating surfaces and become entangled. Failure to comply with this warning may result in serious personal injury.

Test Run

Once mounting is complete and adjustments are done to your satisfaction, you are ready to test the machine.

!WARNING

All grinding wheels have the potential of breaking apart during operation, causing serious personal injury or death! Always stand to the side of the grinder when turning it **ON** and wear the proper safety equipment to protect yourself.

To test run the grinder/sander:

1. Plug the machine into the power source.
2. Stand to the side of the grinding wheel and turn the grinder **ON**.

The machine should run smoothly with little or no vibration or rubbing noises. Strange or unusual noises should be investigated and corrected before operating the machine further. If the machine seems okay, stay out of the line of rotation of the grinding wheel and let it run for 1-2 minutes to make sure the wheel is structurally sound.

If you cannot easily locate the source of an unusual noise or vibration, contact our Technical Support department for help.

NOTICE

This section provides only a basic description of grinder/sander applications. There are many different grinding wheels and sanding belts available for your grinder/sander. **WE STRONGLY RECOMMEND** that you read books, trade magazines, or get formal training to maximize the potential of your machine.



Before Grinding

The grinder is a safe tool when used properly. In addition to the safety instructions in this manual, the most important safety consideration is to use common sense at all times. What may be okay in one situation, may not be safe in another.

Read the following statements to protect yourself before grinding:

- Make sure all guards and eye shields are in place.
- Stand to the side of the grinder when you turn it on and allow it to run for one full minute before EVERY use.
- Make sure that you have mounted your grinder securely and that you have performed the “Test Run” instructions in this manual.
- Remember that grinding often produces sparks. DO NOT allow anyone to stand in the path of the sparks. DO NOT grind near flammable liquids or gases.
- Wear the proper protective clothing. Remember that particles flying off of a grinding wheel will be traveling very fast—prepare for this. Wear safety glasses or a face shield, a dust mask, earplugs, a leather apron, and heavy leather boots.
- DO NOT lean into the workpiece in a manner that may cause your hands to move into the spinning wheel if the workpiece slips off.
- Concentrate on the task at hand. STOP grinding/sanding if there are distractions.
- DO NOT grind on the side of the wheel. Although side grinding is permissible for some wheel types, the Model H7760 is not designed for side grinding.

Operating Grinder

The grinder is designed for use with hard metals only. Soft metals and wood products should only be used on the sanding belt, as they will quickly load the grinding wheel surface and ruin its abrasive qualities.

WARNING

Grinding accidents can cause serious injury or death! Protect yourself by reading and following all preceding safety information in this manual before grinding.

To grind with the grinding wheel:

1. Fill the coolant tray $\frac{3}{4}$ full with water.
2. With the machine plugged into power, stand to the side of the grinding wheel, and move the red switch to the **ON** position.
3. Allow the machine to run for at least 1 full minute to ensure that the grinding wheel is safe for use, then move to the front of the machine.
4. Grasp the workpiece tightly and properly support it on the tool rest.
5. Place the workpiece against the front surface of the wheel with moderate pressure, moving it back and forth in a steady, even motion.

Note: *Using too much pressure will slow the motor and may damage the wheel. Using too little pressure will make the workpiece bounce around and you will not make good contact with the wheel.*
6. Regularly dip the workpiece into the coolant tray to cool it off.
7. When you are ready to stop the grinder, move the red switch to the **OFF** position. At this point, DO NOT continue grinding and DO NOT manually stop the grinding wheel with your workpiece!



Wheel Care

Your safety depends, on a large part, on the condition of the wheel during grinding. A wheel in poor condition presents the possibility of breaking apart during rotation, injuring the operator and possibly causing property damage.

To properly care for your wheel, follow these tips:

- Always transport, store and handle wheels with care. Wheels may be damaged if they are dropped or if heavy objects are stacked on them.
- Select the right grinding wheel for the job. **DO NOT** grind material that is not designed for the wheel.
- Select the right wheel for the machine. A machine that rotates at a higher RPM than the wheel rating may cause the wheel to fly apart.
- Mount the wheels properly. (See the “Replacing Wheels” instructions on **Page 18** for guidance.) Never use a wheel with the wrong arbor size for the grinder.
- **DO NOT** abuse the wheel by jamming the work into the grinding wheel with excessive force.
- Learn how to use the grinder and the grinding wheels properly. Ask a trusted person with experience or consult with your local library to learn more.
- Grinding on the side of the wheel may cause wheel damage.
- Dress the grinding wheel when the surface loses its abrasive quality or “bite.”

Wheel Dressing

Dressing restores the grinding wheel with a like-new abrasive quality. Whenever the front surface of the wheel loses its abrasive qualities (loading or polishing), then the wheel should be dressed. A dressing tool is included for this purpose.

To dress the grinding wheel:

1. With the machine plugged into power, stand to the side of the grinding wheel and move the red switch to the **ON** position.
2. Allow the machine to run for at least 1 full minute to make sure that the grinding wheel is not going to fly apart and injure you, then move to the front of the machine.
3. Hold the dressing tool firmly on the tool rest with both hands and press it lightly against the front surface of the grinding wheel as shown in **Figure 10**.



Figure 10. Using wheel dressing tool.

4. Move the dressing tool in a side-to-side motion, while keeping it even with the front surface of the grinder.
5. Regularly pull the dressing tool away from the wheel for visual inspection and repeat **Steps 3 & 4** until the surface of the wheel appears to be restored to its normal color and texture.



Wheel Selection

The Model H7760 only accepts Type 1 wheels with a 1/2" bore.

Aluminum oxide and silicon carbide wheels are marked in a somewhat uniform manner by all major manufacturers. Understanding these markings will help you understand the capabilities of various wheels. Always refer to the manufacturer's grinding recommendations when selecting a wheel for your project.

The basic format for wheel numbering is:

Prefix	Abrasive	Grit	Grade Type	Bond Type
Type 1	A	60	L	V

The *Prefix* is the manufacturer's designation for a particular type.

The most common *Abrasive Types* used are A for Aluminum Oxide and C for Silicon Carbide, and occasionally SG for Seeded Gel.

The *Grit Size* is a number that refers to the size of the abrasive grain in the wheel. The lower the number, the coarser the wheel. Grit sizes range from 10, which is a very coarse grit used for roughing, to 220, which is usually the upper range for fine finish work.

Grade Type is an indication of the hardness of the wheel—"A" being the softest and "Z" being the hardest.

Bond Type refers to the type of bonding material used to hold the abrasive material. Most general purpose wheels will have a "V" indicating Vitrified Clay is used. Vitrified Clay provides high strength and good porosity. The other common bond type is "B" for resin where synthetic resins are used. These are used to grind cemented carbide and ceramic materials.

There may be other numbers inserted that have meaning for a particular type of wheel. Refer to the manufacturer's technical data for a complete explanation.



Wheel Inspection

Before mounting a new grinding wheel, it must be inspected. DO NOT assume that a wheel is in sound condition just because it is new—often, damage can occur during shipping, with age, or with exposure to moisture.

First, the wheel should be given a **Visual Inspection**. Look for any cracks, chips, nicks, or dents in the surface of the wheel. If you see any of these, DO NOT use the wheel.

Second, the wheel should be given a **Ring Test**. This test will give you an indication of any internal damage that may not be obvious during a visual inspection.

To perform a Ring Test:

1. Make sure the wheel that you test is clean and dry; otherwise, you may get false results.
2. If size permits, balance the wheel with your finger in the hole. If this is not possible, hang the wheel in the air with a piece of cord or string looped through the hole in the center.
3. At the spots shown in **Figure 11**, gently tap the wheel with a light non-metallic device such as the handle of a screwdriver or a wooden mallet.

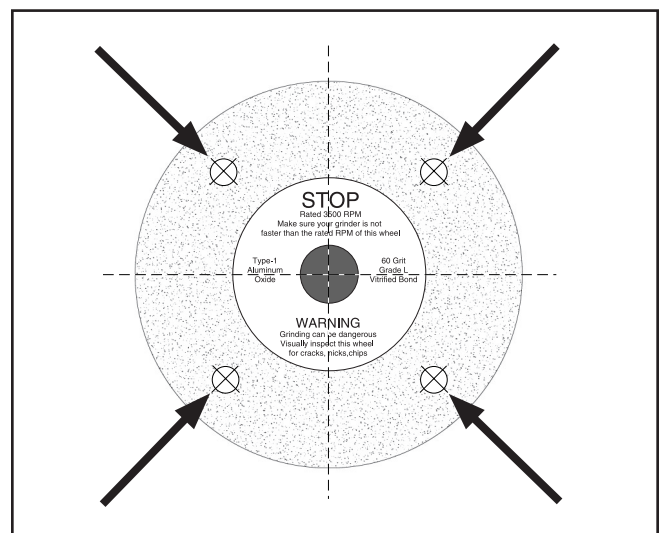

Figure 11. Ring test tapping locations.

4. An undamaged wheel will emit a clear metallic ring or “ping” sound in each of these spots. A damaged wheel will respond with a dull thud that has no clear tone.
5. If you determine from the ring test that the wheel is damaged, DO NOT use it!

Replacing Wheels

The wheel guard assembly must be removed in order to mount or dismount a grinding wheel.

⚠️ WARNING

The hazards of using a damaged wheel include flying chunks of sharp abrasive material that could cause serious injury or death. Inspect every grinding wheel before it is mounted and DO NOT use a damaged grinding wheel!

To remove/mount a wheel:

1. DISCONNECT THE MACHINE FROM THE POWER SUPPLY!
2. Remove the three Phillips head screws and nuts that go through the outer guard. Take off the outer guard and the rim guard.
3. Use a wrench on the nut that holds the wheel on the arbor. Hold the wheel from turning with your other hand.

Note: The grinding wheel arbor has a left-handed thread, so loosening the nut will require turning it clockwise.

4. Remove the outer wheel flange and paper disc. Pull the wheel free from the arbor. There will also be a paper disc and a wheel flange on the back side of the wheel which should also be removed.

5. Mount the new wheel in the reverse order or as shown in **Figure 12**. Always make certain there is a paper or fiber disc between the wheel flanges and the wheel itself. Tighten the nut snugly but DO NOT over-tighten. Over-tightening can crack the wheel.

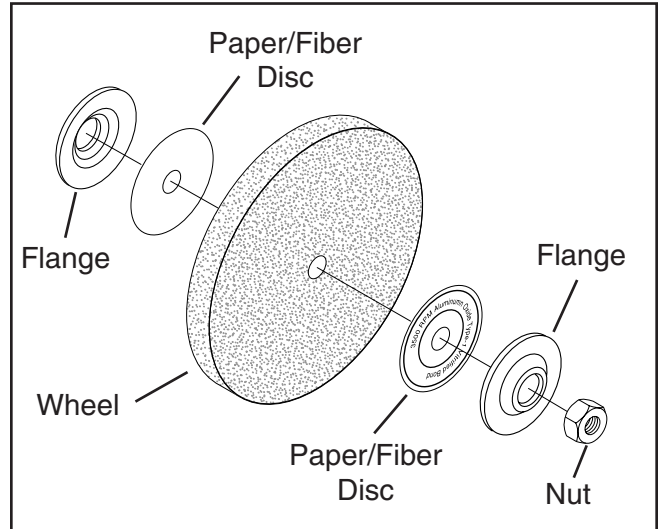

Figure 12. Wheel mounting order.

⚠️ CAUTION

Omitting the paper discs during assembly can put undue stress on the wheel, causing it to crack and possibly fall apart! NEVER assemble a grinding wheel on the arbor without paper or fiber discs between the wheel and the flanges.

6. Re-install the guards and shields.
7. Run a new wheel for at least one minute while standing clear of the line of rotation. If a wheel does have defects it will generally fail as soon as it gets up to full speed.



Sanding

The 2" sanding belt on the Model H7760 works great for non-ferrous metals and wood products. A wide variety of belts are also available for many types of materials and stages of finishing.

CAUTION

The sanding belt will remove large amounts of material quickly, including your skin. **DO NOT** touch the sanding belt and always position your hands so they will not slip into the belt or get caught in the belt.

To sand a workpiece:

1. Before starting the machine, adjust the angle of the tool rest so your workpiece can be properly supported and the area you wish to sand will be parallel with the sanding belt as illustrated in **Figure 13**.

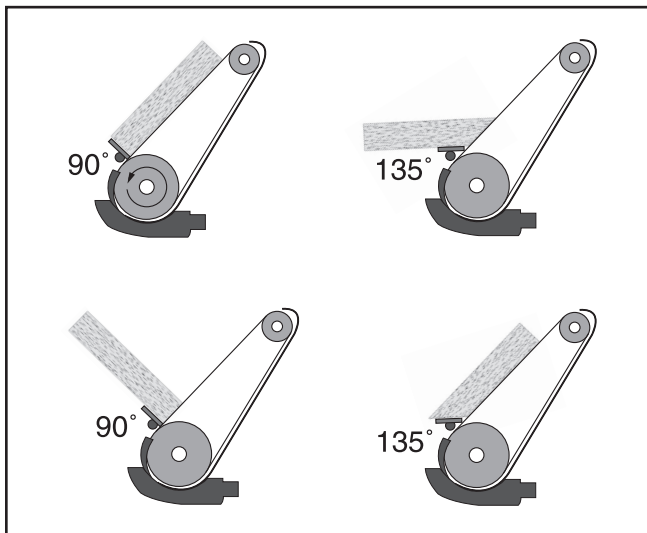

Figure 13. Examples of tool rest angles.

2. With the machine plugged into power, stand to the side of the grinding wheel, and move the red switch to the **ON** position.
3. Allow the machine to run for at least 1 full minute to make sure that the grinding wheel is not going to fly apart and injure you, then move to the front of the machine.

4. Grasp the workpiece tightly and properly support it on the tool rest.
5. Press the workpiece evenly against the sanding belt with light pressure (see **Figures 14 and 15**). **DO NOT** press hard—let the rotation of the belt do the work



Figure 14. Sanding a workpiece.



Figure 15. Sanding a workpiece.

6. Remove your workpiece regularly to check the progress the sander has made. *Remember—you can always remove more material but you cannot add it!*
7. When you are finished sanding, move the red switch to the **OFF** position. **DO NOT** continue sanding and **DO NOT** manually stop the sanding belt with your workpiece!



Replacing Belts

Many belts are available with different grit sizes.

To remove/replace a sanding belt:

1. DISCONNECT THE MACHINE FROM THE POWER SUPPLY!
2. Remove the star knob from the right-hand sanding belt cover as shown in **Figure 16**, and remove the cover.



Figure 16. Star knob removed.

3. Loosen the sanding belt tension knob, as shown in **Figure 17**.



Figure 17. Sanding belt tension knob.

4. Pull the sanding belt tension knob down with one hand and work the sanding belt off the rollers with the other hand as shown in **Figure 18**.



Figure 18. Removing sanding belt.

5. Install the new sanding belt in the reverse order of removal and replace the belt cover.
6. Track the new sanding belt as shown on **Page 13** BEFORE turning the machine **ON**.



SECTION 5: ACCESSORIES

- G7984—Face Shield
- H1298—Dust Sealed Safety Glasses
- H1300—UV Blocking, Clear Safety Glasses
- H2347—Uvex® Spitfire Safety Glasses
- H0736—Shop Fox® Safety Glasses

Safety Glasses are essential to every shop. If you already have a pair, buy extras for visitors or employees. You can't be too careful when it comes to shop safety!



Figure 19. Our most popular safety glasses.

2" x 27" Silicon Carbide Sanding Belts

Our silicon carbide sanding belts are available in packs of ten.

MODEL	SIZE	GRIT
H5016	2" x 27"	60
H5017	2" x 27"	80
H5018	2" x 27"	100
H5019	2" x 27"	120
H5020	2" x 27"	150
H5021	2" x 27"	180
H5022	2" x 27"	220

- PRO-STIK® Belt Cleaners
- G1511—Large (1½" x 1½" x 8½")
- G1512—Small (2" x 2" x 12")
- H1446—1¾" x 4¼"
- H1447—1¾" x 8½"

These crepe-rubber Belt Cleaners quickly remove gum and grit from belts and discs without damage. Extend the life of your belts or discs with this innovative natural cleaner.



Figure 20. PRO-STIK® Belt Cleaners.

Type 1 Grinding Wheels

Aluminum Oxide wheels are used for all kinds of general grinding. Silicon Carbide wheels are for grinding carbide. More of our wide range can be found in the latest Grizzly catalog.

MODEL	SIZE	BORE	GRIT	ABRASIVE
G1979	6" x ¾"	½"	36	Aluminum Oxide
G1980	6" x ¾"	½"	60	Aluminum Oxide
G1981	6" x ¾"	½"	120	Silicon Carbide

Call 1-800-523-4777 To Order



SECTION 6: MAINTENANCE

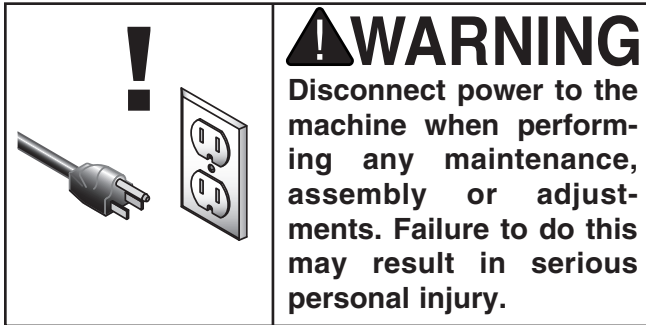

General

Always be aware of the condition of your machine. Routinely check the condition of the following items and repair or replace as necessary:

- Damaged or loose grinding wheel
- Loose mounting bolts
- Worn switch
- Worn or damaged cord
- Worn or damaged support bearings
- Any other condition that could hamper the safe operation of this machine.

Lubrication

Sealed and pre-lubricated ball bearings require no lubrication for the life of the bearings. All bearings are standard sizes, and replacements can be purchased from our Parts Department or a bearing supply store.

Grinding Wheels

The grinding wheel should be inspected before every use. Use the “ring test” method on **Page 17** to verify the structural integrity. Take care in storing grinding wheels to keep them free from potential damage due to being dropped or having other items dropped on them.

Replace the wheel when the wheel diameter is reduced to 5". Operating at anything less than this diameter does not allow the proper alignment of the tool rest and the eye shield.

Depending on the type of grinding you do, the grinding wheel may require periodic dressing. Refer to the “Wheel Dressing” instructions on **Page 18** for details on how this is done.

Sanding Belts

Sanding belts can be cleaned (“unloaded”) with commercially-available crepe-rubber belt cleaners. To clean, simply press the belt cleaner up against the moving belt and move across the surface of the belt until all wood dust has been removed. Grizzly's line of professional-grade PRO-STIK® belt cleaners can be found on **Page 21**.



SECTION 7: SERVICE

Review the troubleshooting and procedures in this section to fix your machine if a problem develops. If you need replacement parts or you are unsure of your repair skills, then feel free to call our Technical Support department at (570) 546-9663.

Troubleshooting

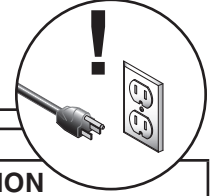

SYMPTOM	POSSIBLE CAUSE	CORRECTIVE ACTION
Motor will not start.	<ol style="list-style-type: none"> 1. Low voltage. 2. Open circuit in motor or loose connections. 	<ol style="list-style-type: none"> 1. Check power line voltage and correct if necessary. 2. Inspect all lead connections on motor for loose or open connections.
Motor will not start; fuses or circuit breakers blow.	<ol style="list-style-type: none"> 1. Short circuit in line cord or plug. 2. Short circuit in motor or loose connections. 3. Incorrect fuses or circuit breakers in power line. 	<ol style="list-style-type: none"> 1. Inspect cord and plug for damaged insulation or shorted wires. 2. Inspect all motor connections for loose or shorted terminals or worn insulation. 3. Install correct fuses or circuit breakers.
Motor overheats.	<ol style="list-style-type: none"> 1. Motor overloaded. 	<ol style="list-style-type: none"> 1. Reduce load on motor.
Motor stalls (resulting in blown fuses or tripped circuit).	<ol style="list-style-type: none"> 1. Motor overloaded. 2. Short circuit in motor or loose connections. 3. Low voltage. 4. Incorrect fuses or circuit breakers in power line. 	<ol style="list-style-type: none"> 1. Reduce load on motor. 2. Inspect connections on motor for loose or shorted terminals or worn insulation. 3. Check power line voltage and correct if necessary. 4. Install correct fuses or circuit breakers.
Machine slows when operating.	<ol style="list-style-type: none"> 1. Workpiece pressure is too great. 	<ol style="list-style-type: none"> 1. Reduce workpiece pressure on wheel.
Wavy condition on surface of workpiece.	<ol style="list-style-type: none"> 1. Machine vibrating. 2. Workpiece not being held firmly. 3. Wheel face uneven. 4. Wheel is too hard. 	<ol style="list-style-type: none"> 1. Ensure machine is securely mounted. 2. Use a holding device to firmly retain the workpiece. 3. Dress the grinding wheel. 4. Use softer wheel, or reduce the feed rate.
Lines on surface of workpiece.	<ol style="list-style-type: none"> 1. Impurity on wheel surface. 2. Workpiece not being held tightly. 	<ol style="list-style-type: none"> 1. Dress the grinding wheel. 2. Use a holding device to firmly retain the workpiece.
Burning spots or cracks in the workpiece.	<ol style="list-style-type: none"> 1. Workpiece pressure is too great. 2. Coolant required. 3. Improper type of grinding wheel. 	<ol style="list-style-type: none"> 1. Reduce workpiece pressure on wheel. 2. Add an optional coolant system or cool the workpiece more frequently. 3. Try a wheel which is softer style or a coarser grit.
Wheel dulls quickly, grit falls off.	<ol style="list-style-type: none"> 1. Workpiece pressure is too great. 2. Wheel is too soft. 3. Wheel diameter too small. 4. Bad wheel dress. 5. Defective wheel bonding. 	<ol style="list-style-type: none"> 1. Reduce workpiece pressure on wheel. 2. Select a wheel with a harder bond. 3. Replace the wheel. 4. Dress the wheel. 5. Consult manufacturer of grinding wheel.
Wheel clogs and workpiece shows burn marks.	<ol style="list-style-type: none"> 1. Wheel is too hard. 2. Feed rate too slow. 3. Bad wheel dress. 4. Coolant required. 	<ol style="list-style-type: none"> 1. Select a wheel with a softer bond. 2. Increase the rate of movement of the workpiece onto wheel. 3. Dress the wheel. 4. Add an optional coolant system or cool the workpiece more frequently.



Parts Breakdown

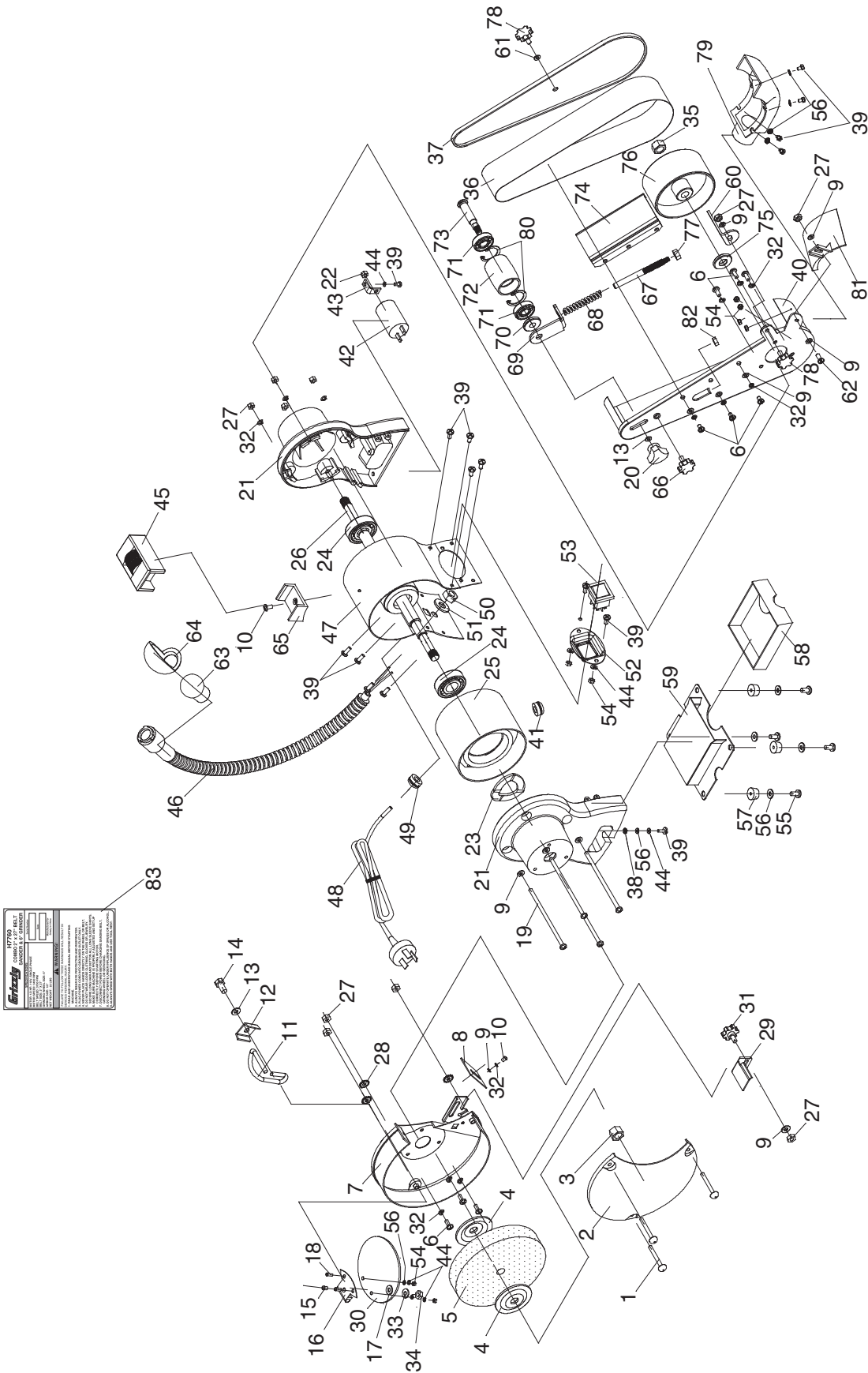

Parts List

REF	PART #	DESCRIPTION
1	PH7760001	PHLP HD SCR M5-.8 X 45
2	PH7760002	LEFT WHEEL COVER
3	PH7760003	HEX NUT M12-1.75 LH
4	PH7760004	FLANGE
5	PH7760005	GRINDING WHEEL A36N5V
6	PH7760006	PHLP HD SCR M5-.8 X 10
7	PH7760007	LEFT SAFE GUARD
8	PH7760008	SPARK BREAKER
9	PH7760009	FLAT WASHER 5MM
10	PH7760010	PHLP HD SCR M5-.8 X 8
11	PH7760011	SUPPORT ARM
12	PH7760012	BRACKET
13	PH7760013	FLAT WASHER 8MM
14	PH7760014	HEX BOLT M8-1.25 X 14
15	PH7760015	CARRIAGE BOLT M6-1.0 X 18
16	PH7760016	EYESHIELD PLATE
17	PH7760017	FLAT WASHER 6MM
18	PH7760018	PHLP HD SCR M4-.7 X 10
19	PH7760019	HOUSING SCR M5-.8 X 123
20	PH7760020	KNOB M8-1.25
21	PH7760021	END BELL
22	PH7760022	HEX NUT M8-1.25
23	PH7760023	WAVY WASHER 28MM
24	PH7760024	BEARING 6202-RS
25	PH7760025	STATOR
26	PH7760026	ROTOR
27	PH7760027	HEX NUT M5-.8
28	PH7760028	EXT TOOTH WASHER 5MM
29	PH7760029	LEFT MOUNT TOOL REST
30	PH7760030	EYESHIELD
31	PH7760031	KNOB BOLT M5-.8 X 10
32	PH7760032	LOCK WASHER 5MM
33	PH7760033	FLAT WASHER 4MM
34	PH7760034	HEX NUT M4-.7
35	PH7760035	HEX NUT M12-1.75
36	PH7760036	SANDING BELT 2" X 27"
37	PH7760037	RIGHT WHEEL COVER
38	PH7760038	EXT TOOTH WASHER 4MM
39	PH7760039	PHLP HD SCR M4-.7 X 8
40	PH7760040	RIGHT SAFE GUARD
41	PH7760041	CORD BUSHING
42	PH7760042	R CAPACITOR 9M 300V

REF	PART #	DESCRIPTION
43	PH7760043	CAPACITOR SUPPORT
44	PH7760044	LOCK WASHER 4MM
45	PH7760045	WHEEL DRESSING TOOL
46	PH7760046	LAMP SUPPORT
47	PH7760047	MOTOR HOUSING
48	PH7760048	CORD & PLUG
49	PH7760049	CORD CLIP
50	PH7760050	HEX NUT M10-1.0
51	PH7760051	LOCK WASHER 10MM
52	PH7760052	SWITCH PLATE
53	PH7760053	SWITCH
54	PH7760054	HEX NUT M4-.7
55	PH7760055	PHLP HD SCR M4-.7 X 15
56	PH7760056	FLAT WASHER 4MM
57	PH7760057	RUBBER FOOT
58	PH7760058	COOLANT TRAY
59	PH7760059	BOTTOM PLATE
60	PH7760060	RIGHT MOUNT TOOL REST
61	PH7760061	FLAT WASHER 5MM
62	PH7760062	PHLP HD SCR M5-.8 X 10
63	PH7760063	BULB S-25 12V 10W
64	PH7760064	LAMPSHADE
65	PH7760065	DRESSING BASE
66	PH7760066	KNOB M6-1.0 X 10
67	PH7760067	ADJUSTMENT ROD
68	PH7760068	SPRING
69	PH7760069	TENSION PLATE
70	PH7760070	DRIVE SHAFT WASHER
71	PH7760071	BALL BEARING 6201ZZ
72	PH7760072	UPPER DRIVE CYLINDER
73	PH7760073	DRIVE SHAFT
74	PH7760074	WORK SUPPORT
75	PH7760075	DRIVE SHAFT SPACER
76	PH7760076	LOWER DRIVE CYLINDER
77	PH7760077	HEX NUT M6-1.0
78	PH7760078	KNOB BOLT M5-.8 X 10
79	PH7760079	DUST PORT
80	PH7760080	INT RETAIN RING 32MM
81	PH7760081	SAFE BOARD
82	PH7760082	HEX NUT M5-.8
83	PH7760083	MACHINE ID LABEL

WARNING

Safety labels warn about machine hazards and ways to prevent injury. The owner of this machine **MUST** maintain the original location and readability of the labels on the machine. If any label is removed or becomes unreadable, **REPLACE** that label before using the machine again. Contact Grizzly at (800) 523-4777 or www.grizzly.com to order new labels.



WARRANTY AND RETURNS

Grizzly Industrial, Inc. warrants every product it sells for a period of **1 year** to the original purchaser from the date of purchase. This warranty does not apply to defects due directly or indirectly to misuse, abuse, negligence, accidents, repairs or alterations or lack of maintenance. This is Grizzly's sole written warranty and any and all warranties that may be implied by law, including any merchantability or fitness, for any particular purpose, are hereby limited to the duration of this written warranty. We do not warrant or represent that the merchandise complies with the provisions of any law or acts unless the manufacturer so warrants. In no event shall Grizzly's liability under this warranty exceed the purchase price paid for the product and any legal actions brought against Grizzly shall be tried in the State of Washington, County of Whatcom.

We shall in no event be liable for death, injuries to persons or property or for incidental, contingent, special, or consequential damages arising from the use of our products.

To take advantage of this warranty, contact us by mail or phone and give us all the details. We will then issue you a "Return Number," which must be clearly posted on the outside as well as the inside of the carton. We will not accept any item back without this number. Proof of purchase must accompany the merchandise.

The manufacturers reserve the right to change specifications at any time because they constantly strive to achieve better quality equipment. We make every effort to ensure that our products meet high quality and durability standards and we hope you never need to use this warranty.

Please feel free to write or call us if you have any questions about the machine or the manual.

Thank you again for your business and continued support. We hope to serve you again soon.





WARRANTY CARD

Name _____
 Street _____
 City _____ State _____ Zip _____
 Phone # _____ Email _____ Invoice # _____
 Model # _____ Order # _____ Serial # _____

The following information is given on a voluntary basis. It will be used for marketing purposes to help us develop better products and services. **Of course, all information is strictly confidential.**

1. How did you learn about us?

Advertisement Friend Catalog
 Card Deck Website Other:

2. Which of the following magazines do you subscribe to?

<input type="checkbox"/> Cabinet Maker	<input type="checkbox"/> Popular Mechanics	<input type="checkbox"/> Today's Homeowner
<input type="checkbox"/> Family Handyman	<input type="checkbox"/> Popular Science	<input type="checkbox"/> Wood
<input type="checkbox"/> Hand Loader	<input type="checkbox"/> Popular Woodworking	<input type="checkbox"/> Wooden Boat
<input type="checkbox"/> Handy	<input type="checkbox"/> Practical Homeowner	<input type="checkbox"/> Woodshop News
<input type="checkbox"/> Home Shop Machinist	<input type="checkbox"/> Precision Shooter	<input type="checkbox"/> Woodsmith
<input type="checkbox"/> Journal of Light Cont.	<input type="checkbox"/> Projects in Metal	<input type="checkbox"/> Woodwork
<input type="checkbox"/> Live Steam	<input type="checkbox"/> RC Modeler	<input type="checkbox"/> Woodworker West
<input type="checkbox"/> Model Airplane News	<input type="checkbox"/> Rifle	<input type="checkbox"/> Woodworker's Journal
<input type="checkbox"/> Modeltec	<input type="checkbox"/> Shop Notes	<input type="checkbox"/> Other:
<input type="checkbox"/> Old House Journal	<input type="checkbox"/> Shotgun News	

3. What is your annual household income?

\$20,000-\$29,000 \$30,000-\$39,000 \$40,000-\$49,000
 \$50,000-\$59,000 \$60,000-\$69,000 \$70,000+

4. What is your age group?

20-29 30-39 40-49
 50-59 60-69 70+

5. How long have you been a woodworker/metalworker?

0-2 Years 2-8 Years 8-20 Years 20+ Years

6. How many of your machines or tools are Grizzly?

0-2 3-5 6-9 10+

7. Do you think your machine represents a good value? Yes No

8. Would you recommend Grizzly Industrial to a friend? Yes No

9. Would you allow us to use your name as a reference for Grizzly customers in your area?
Note: We never use names more than 3 times. Yes No

10. Comments: _____

CUT ALONG DOTTED LINE

FOLD ALONG DOTTED LINE



Place Stamp Here



GRIZZLY INDUSTRIAL, INC.
P.O. BOX 2069
BELLINGHAM, WA 98227-2069



FOLD ALONG DOTTED LINE

Send a Grizzly Catalog to a friend:

Name _____
Street _____
City _____ State _____ Zip _____

TAPE ALONG EDGES--PLEASE DO NOT STAPLE

grizzly.com

TOOL WEBSITE

Buy Direct and Save with Grizzly® – Trusted, Proven and a Great Value!

*Visit Our Website Today And Discover
Why Grizzly® Is The Industry Leader!*

- SECURE ORDERING
- ORDERS SHIPPED WITHIN 24 HOURS
- E-MAIL RESPONSE WITHIN ONE HOUR

-OR-

Call Today For A **FREE**
Full Color Catalog

1-800-523-4777

