

READ THIS FIRST



Model G9729

IMPORTANT UPDATE

For Machines Mfd. Since 4/18
and Owner's Manual Revised 9/13

For questions or help with this product contact Tech Support at (570) 546-9663 or techsupport@grizzly.com

The following changes were recently made since the owner's manual was printed:

- Parts revised to show new motor. Motor specs updated.

Aside from this information, all other content in the owner's manual applies and **MUST** be read and understood for your own safety. **IMPORTANT: Keep this update with the owner's manual for future reference.**

For questions or help, contact our Tech Support at (570) 546-9663 or techsupport@grizzly.com.

Revised Lathe Bed Parts

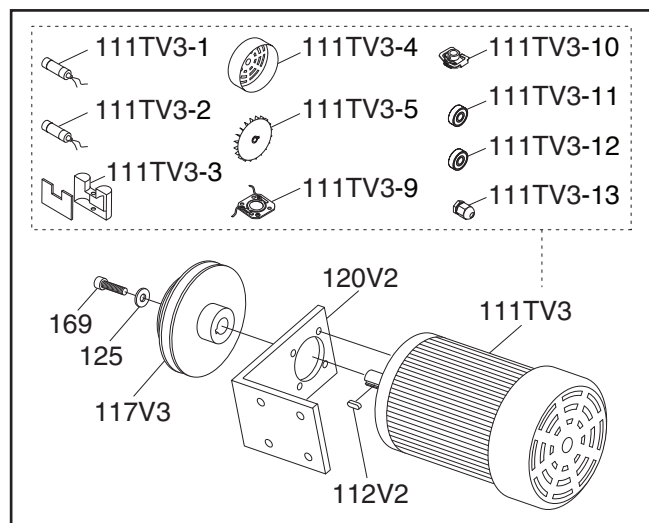

REF	PART #	DESCRIPTION
111TV3	P9729111TV3	MOTOR 3/4HP 110V 1-PH V3.04.18
111TV3-1	P9729111TV3-1	R CAPACITOR 50M 450V 1-13/16 X 3-1/2
111TV3-2	P9729111TV3-2	S CAPACITOR 300M 250V 1-5/8 X 3-1/2
111TV3-3	P9729111TV3-3	MOTOR JUNCTION BOX
111TV3-4	P9729111TV3-4	MOTOR FAN COVER
111TV3-5	P9729111TV3-5	MOTOR FAN
111TV3-9	P9729111TV3-9	CONTACT PLATE
111TV3-10	P9729111TV3-10	CENTRIFUGAL SWITCH
111TV3-11	P9729111TV3-11	BALL BEARING 6204-2RS (FRONT)
111TV3-12	P9729111TV3-12	BALL BEARING 6204-2RS (REAR)
111TV3-13	P9729111TV3-13	STRAIN RELIEF TYPE-3 M18-1.5
112V2	P9729112V2	KEY 6 X 6 X 30 V2.04.18
117V3	P9729117V3	MOTOR PULLEY V3.04.18
120V2	P9729120V2	MOTOR MOUNT V2.04.18
125	P9729125	FLAT WASHER 6MM
169	P9729169	CAP SCREW M6-1 X 55

Revised Headstock Parts

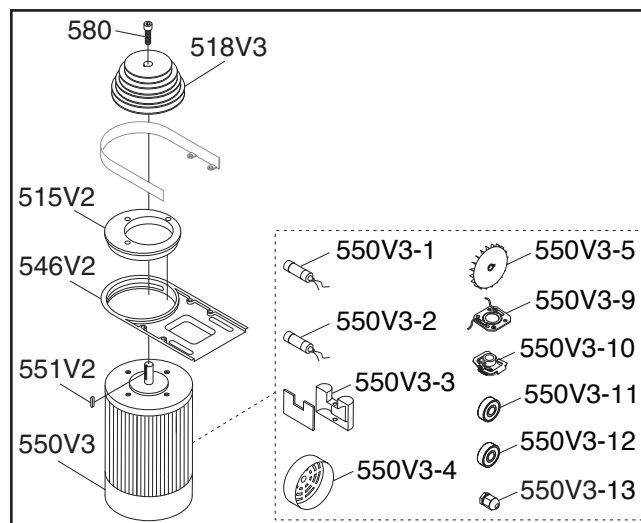

REF	PART #	DESCRIPTION
515V2	P9729515V2	ECCENTRIC FLANGE V2.04.18
518V3	P9729518V3	MOTOR PULLEY V3.04.18
546V2	P9729546V2	MOTOR MOUNT V2.04.18
550V3	P9729550V3	MOTOR 3/4HP 110V 1-PH V3.04.18
550V3-1	P9729550V3-1	R CAPACITOR 50M 450V 1-13/16 X 3-1/2
550V3-2	P9729550V3-2	S CAPACITOR 300M 250V 1-5/8 X 3-1/2
550V3-3	P9729550V3-3	MOTOR JUNCTION BOX
550V3-4	P9729550V3-4	MOTOR FAN COVER
550V3-5	P9729550V3-5	MOTOR FAN
550V3-9	P9729550V3-9	CONTACT PLATE
550V3-10	P9729550V3-10	CENTRIFUGAL SWITCH
550V3-11	P9729550V3-11	BALL BEARING 6204-2RS (FRONT)
550V3-12	P9729550V3-12	BALL BEARING 6204-2RS (REAR)
550V3-13	P9729550V3-13	STRAIN RELIEF TYPE-3 M18-1.5
551V2	P9729551V2	KEY 6 X 6 X 30 V2.04.18
580	P9729580	CAP SCREW M6-1 X 45

COPYRIGHT © NOVEMBER, 2018 BY GRIZZLY INDUSTRIAL, INC.
WARNING: NO PORTION OF THIS MANUAL MAY BE REPRODUCED IN ANY SHAPE OR FORM WITHOUT THE WRITTEN APPROVAL OF GRIZZLY INDUSTRIAL, INC.

#MN20049 PRINTED IN CHINA

Revised Specifications

Electrical:

Full-Load Current Rating.....8.5A

Motors:

Lathe Spindle

Amps8.5A
Speed.....1700 RPM

Mill Spindle

Amps8.5A
Speed.....1700 RPM



Grizzly *Industrial, Inc.*®

COMBINATION LATHE/MILL MODEL G9729 INSTRUCTION MANUAL

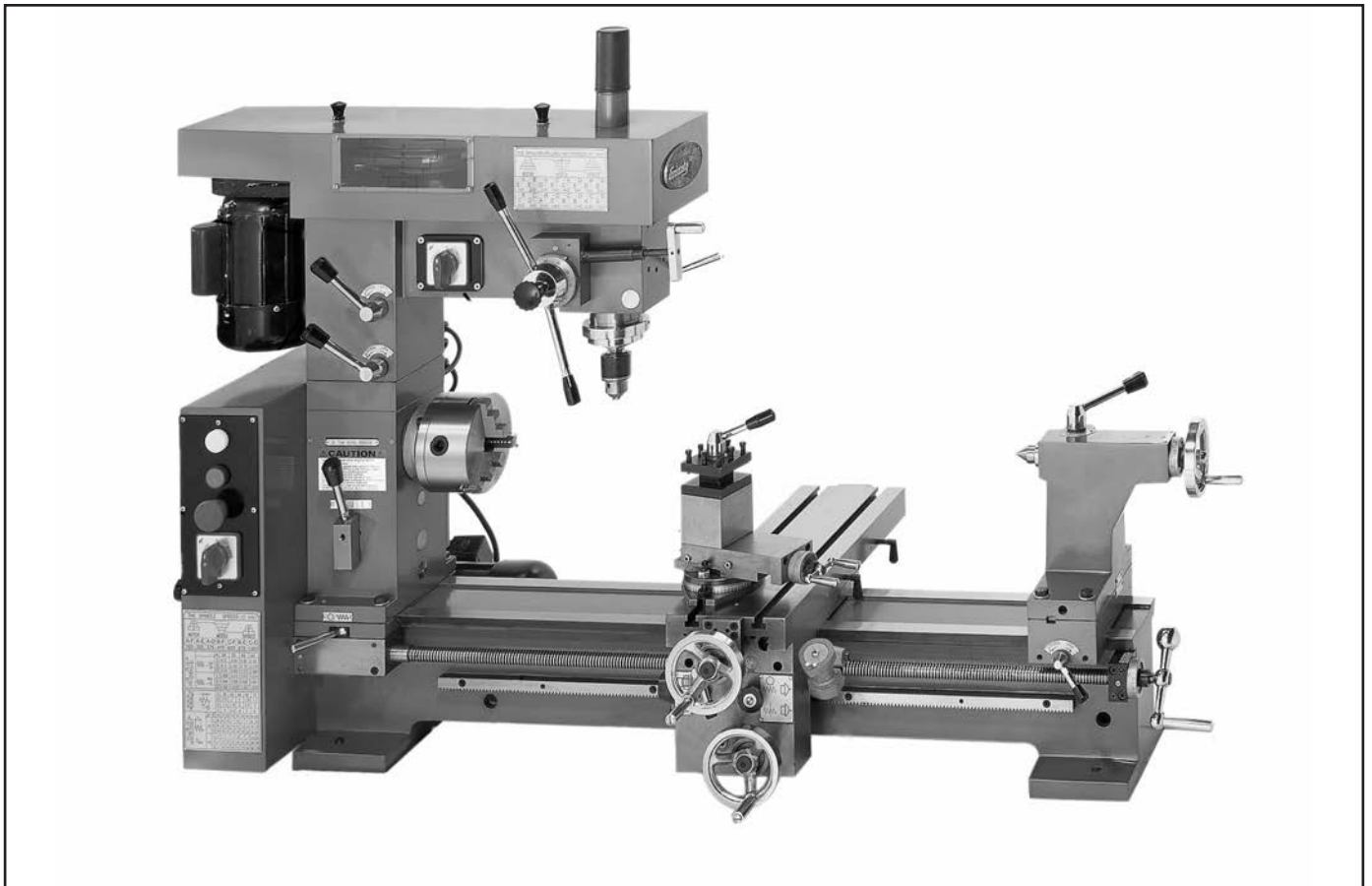

COPYRIGHT © MAY, 2005 BY GRIZZLY INDUSTRIAL, INC. REVISED SEPTEMBER, 2013 (ST)

**WARNING: NO PORTION OF THIS MANUAL MAY BE REPRODUCED IN ANY SHAPE
OR FORM WITHOUT THE WRITTEN APPROVAL OF GRIZZLY INDUSTRIAL, INC.**

#PC3395 PRINTED IN CHINA

WARNING

Some dust created by power sanding, sawing, grinding, drilling, and other construction activities contains chemicals known to the State of California to cause cancer, birth defects or other reproductive harm. Some examples of these chemicals are:

- Lead from lead-based paints.
- Crystalline silica from bricks, cement, and other masonry products.
- Arsenic and chromium from chemically treated lumber.

Your risk from these exposures varies, depending on how often you do this type of work. To reduce your exposure to these chemicals: work in a well ventilated area, and work with approved safety equipment, such as those dust masks that are specially designed to filter out microscopic particles.

Table of Contents

- INTRODUCTION..... 3**
 - Foreword 3
 - Contact Info 3
 - Machine Data Sheet..... 4
 - Identification 5
- SECTION 1: SAFETY 6**
 - Safety Instructions for Machinery..... 6
 - Additional Safety Instructions for Lathe/Mills 8
 - Glossary Of Terms 9
- SECTION 2: CIRCUIT REQUIREMENTS 10**
 - 110V Operation 10
- SECTION 3: SET UP 11**
 - Set Up Safety 11
 - Items Needed For Set Up 11
 - Unpacking 11
 - Inventory..... 12
 - Hardware Recognition Chart..... 13
 - Clean Up 14
 - Site Considerations 14
 - Moving & Placing Base Unit..... 15
 - Hand Crank 16
 - Handwheels..... 16
 - Steady and Follow Rest Removal..... 17
 - Test Run..... 18
- SECTION 4: LATHE OPERATIONS 19**
 - Operation Safety 19
 - Lathe Chuck Removal 20
 - Lathe Chucks with Mounting Plate..... 21
 - Chuck Jaws 22
 - Replacing Jaws 23
 - Face Plate 24
 - Dead Center 25
 - Tool Post 26
 - Tailstock Controls..... 27
 - Tailstock 27
 - Tailstock Drill Mounting 29
 - Tailstock Drill Removal..... 29
 - Carriage Controls 30
 - Carriage Lock..... 31
 - Follow Rest..... 32
 - Steady Rest..... 33
 - Lathe Speeds 34
 - Start Up and Spindle Break-in Procedures 35
 - Feed Lever 35
 - Feed Selection 36
 - Reading the Charts 37
 - Feed Rates..... 37

Half Nut	38
Apron Power Feed	38
Changing Gears	39
Inch Threading	40
Cutting Threads.....	42
Metric Threading	43
SECTION 5: MILL OPERATIONS.....	44
Mill Speeds.....	44
Head Rotation	45
Quill Lock Lever	45
Quill Lock Lever	45
Fine Down Feed.....	45
Machine Vise.....	46
Drill Chuck Removal.....	47
Drill Chuck Mounting	47
SECTION 6: ACCESSORIES.....	48
SECTION 7: MAINTENANCE.....	50
Schedule	50
Cleaning	50
Unpainted Cast Iron	50
Lubrication.....	51
SECTION 8: SERVICE	53
About Service.....	53
Gibs	53
Troubleshooting.....	55
Electrical Diagram	56
Electrical Components	57
PARTS	58
G9729 Lathe Bed	58
G9729 Parts Breakdown 0-199 Series	59
G9729 Lower Head Assembly	60
G9729 Parts Breakdown 200 Series.....	61
G9729 Belt Guard	62
G9729 Parts Breakdown 300 Series.....	63
G9729 Parts Breakdown 400 Series.....	63
G9729 Headstock Assembly.....	64
G9729 Parts Breakdown 500 & 600 Series	65
G9729 Crossslide Assembly	66
G9729 Parts Breakdown 700 Series.....	67
G9729 Apron Assembly	68
G9729 Parts Breakdown T Series	69
G9729 Rests Assemblies.....	70
G9729 Compound Assembly	71
G9729 Tailstock Assembly.....	72
G9729 Parts Breakdown 900 Series.....	73
WARRANTY AND RETURNS	74

INTRODUCTION

Foreword

We are proud to offer the Model G9729 Combination Lathe/Mill. This machine is part of a growing Grizzly family of fine metalworking machinery. When used according to the guidelines set forth in this manual, you can expect years of trouble-free, enjoyable operation and proof of Grizzly's commitment to customer satisfaction.

We are pleased to provide this manual with the Model G9729. It was written to guide you through assembly, review safety considerations, and cover general operating procedures. It represents our effort to produce the best documentation possible.

The specifications, drawings, and photographs illustrated in this manual represent the Model G9729 as supplied when the manual was prepared. However, owing to Grizzly's policy of continuous improvement, changes may be made at any time with no obligation on the part of Grizzly. For your convenience, we always keep current Grizzly manuals available on our website at **www.grizzly.com**. Any updates to your machine will be reflected in these manuals as soon as they are complete. Visit our site often to check for the latest updates to this manual!



Contact Info

If you have any comments regarding this manual, please write to us at the address below:

Grizzly Industrial, Inc.
c/o Technical Documentation
P.O. Box 2069
Bellingham, WA 98227-2069

We stand behind our machines. If you have any service questions or parts requests, please call or write us at the location listed below.

Grizzly Industrial, Inc.
1203 Lycoming Mall Circle
Muncy, PA 17756
Phone: (570) 546-9663
Fax: (800) 438-5901
E-Mail: techsupport@grizzly.com
Web Site: <http://www.grizzly.com>





MACHINE DATA SHEET

Customer Service #: (570) 546-9663 • To Order Call: (800) 523-4777 • Fax #: (800) 438-5901

MODEL G9729 COMBO LATHE/MILL

Design Type: Bench Model

Overall Dimensions:

Overall Length.....	58"
Overall Width.....	40½"
Overall Height.....	40"
Bed Width.....	5½"
Spindle Bore.....	1⅛"
Spindle Taper.....	MT#4
Tailstock, Mill Head Taper.....	MT#3
Weight (Net).....	525 lbs.
Weight (Shipping).....	692 lbs.
Crate Size.....	56½" L x 23" W x 42" H
Footprint.....	19" x 50"

Lathe Capacity:

Swing Over Bed.....	16½"
Swing Over Saddle.....	11½"
Distance Between Centers.....	31"
Spindle Type.....	Intrinsic 5" Back Plate
Compound Travel.....	3"
Cross Slide Travel.....	3¾"
Tailstock Quill Travel.....	2½"
Spindle Speeds.....	175, 325, 400, 525, 650, 950, 1425 RPM
Feed Rate Range.....	0.002" - 0.014"
Thread Range Inch.....	4 TPI -120 TPI in 44 Steps (Gear changes required)
Thread Range Metric.....	14 @ .75 - 6.0 mm

Mill Capacity: (Measured without Drill Chuck)

Swing.....	22"
Spindle to Bed.....	14½"
Spindle Travel.....	4 ⁵ / ₁₆ "
Spindle to Work Table.....	12 ¹ / ₁₆ "
Spindle to Vise.....	8 ⁹ / ₁₆ "
Spindle to Center line.....	6 ¹ / ₈ "
Vise Jaw Opening.....	3 ¹ / ₈ "
Head Stock Height.....	3 ¹ / ₈ "
Range of Speeds.....	120—3000 RPM
Number of Speeds.....	16
Drill Chuck Capacity.....	½"

2 Motors:

Type.....	TEFC Capacitor Start Induction
Horsepower (Each Motor).....	¾ HP
Switch.....	Reversing
Phase.....	Single Phase
Voltage.....	110V
Amps.....	8.8
RPM (Each Motor).....	1725
Bearings.....	Shielded And Lubricated For Life

Features:

.....	5" 3-Jaw Chuck
.....	T- Slots in Cross Slide
.....	10 Change Gears
.....	Carriage Lock
.....	2 Dead Centers
.....	Power Cross Feed

Specifications, while deemed accurate, are not guaranteed.

Identification

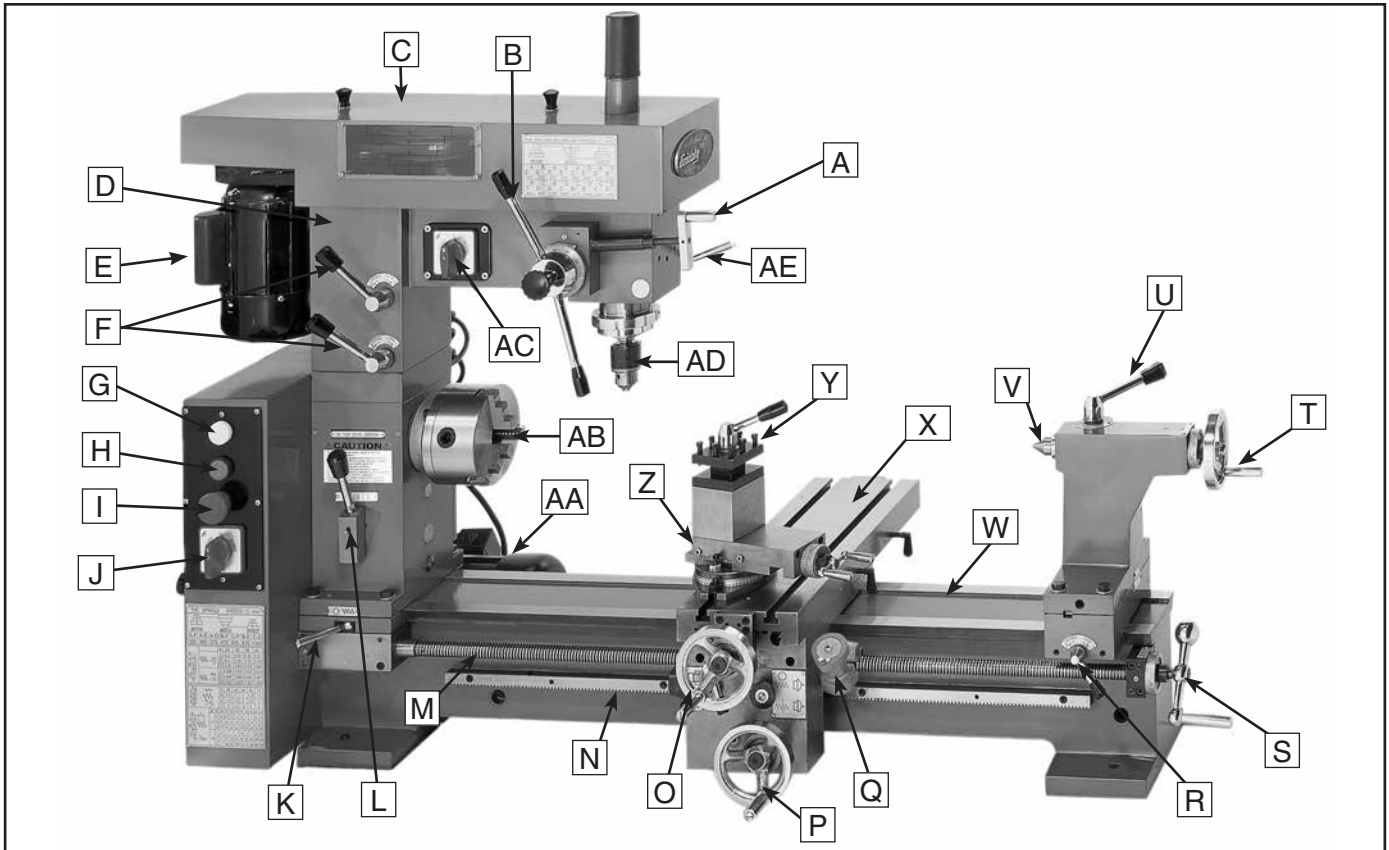

Figure 1. G9729 Controls and features.

- | | |
|-------------------------------------|----------------------------------|
| A. Fine Downfeed Handle | Q. Thread Chasing Dial |
| B. Quill Downfeed Lever | R. Tailstock Lock Lever |
| C. Upper Belt Guard | S. Leadscrew Hand Crank |
| D. Head Stock | T. Tailstock Handwheel |
| E. Mill/Drill Motor | U. Tailstock Quill Lock |
| F. Head Locks | V. Tailstock Center |
| G. Power Indicator | W. Lathe Bed |
| H. ON Switch | X. Mill Table |
| I. Emergency Stop | Y. Tool Post |
| J. Reversing Switch—Lathe | Z. Compound Slide |
| K. Feed Lever | AA. Lathe Motor |
| L. Feed Rate Selection Lever | AB. 3-Jaw Chuck |
| M. Leadscrew | AC. Reversing Switch—Mill |
| N. Gear Rack | AD. Drill Chuck |
| O. Cross Slide Handwheel | AE. Quill Lock |
| P. Longitudinal Handwheel | |



SECTION 1: SAFETY

WARNING

For Your Own Safety, Read Instruction Manual Before Operating this Machine

The purpose of safety symbols is to attract your attention to possible hazardous conditions. This manual uses a series of symbols and signal words which are intended to convey the level of importance of the safety messages. The progression of symbols is described below. Remember that safety messages by themselves do not eliminate danger and are not a substitute for proper accident prevention measures.

 **DANGER** Indicates an imminently hazardous situation which, if not avoided, **WILL** result in death or serious injury.

 **WARNING** Indicates a potentially hazardous situation which, if not avoided, **COULD** result in death or serious injury.

 **CAUTION** Indicates a potentially hazardous situation which, if not avoided, **MAY** result in minor or moderate injury. It may also be used to alert against unsafe practices.

NOTICE This symbol is used to alert the user to useful information about proper operation of the machine.

WARNING

Safety Instructions for Machinery

- 1. READ THROUGH THE ENTIRE MANUAL BEFORE STARTING MACHINERY.** Machinery presents serious injury hazards to untrained users.
- 2. ALWAYS USE ANSI APPROVED SAFETY GLASSES WHEN OPERATING MACHINERY.** Everyday eyeglasses only have impact resistant lenses, they are NOT safety glasses.
- 3. ALWAYS WEAR AN ANSI APPROVED RESPIRATOR WHEN OPERATING MACHINERY THAT PRODUCES DUST.** Wood dust is a carcinogen and can cause cancer and severe respiratory illnesses.
- 4. ALWAYS USE HEARING PROTECTION WHEN OPERATING MACHINERY.** Machinery noise can cause permanent hearing damage.
- 5. WEAR PROPER APPAREL. DO NOT** wear loose clothing, gloves, neckties, rings, or jewelry which may get caught in moving parts. Wear protective hair covering to contain long hair and wear non-slip footwear.
- 6. NEVER OPERATE MACHINERY WHEN TIRED, OR UNDER THE INFLUENCE OF DRUGS OR ALCOHOL.** Be mentally alert at all times when running machinery.

WARNING

Safety Instructions for Machinery

7. **ONLY ALLOW TRAINED AND PROPERLY SUPERVISED PERSONNEL TO OPERATE MACHINERY.** Make sure operation instructions are safe and clearly understood.
8. **KEEP CHILDREN AND VISITORS AWAY.** Keep all children and visitors a safe distance from the work area.
9. **MAKE WORKSHOP CHILD PROOF.** Use padlocks, master switches, and remove start switch keys.
10. **NEVER LEAVE WHEN MACHINE IS RUNNING.** Turn power **OFF** and allow all moving parts to come to a complete stop before leaving machine unattended.
11. **DO NOT USE IN DANGEROUS ENVIRONMENTS.** DO NOT use machinery in damp, wet locations, or where any flammable or noxious fumes may exist.
12. **KEEP WORK AREA CLEAN AND WELL LIT.** Clutter and dark shadows may cause accidents.
13. **USE A GROUNDED EXTENSION CORD RATED FOR THE MACHINE AMPERAGE.** Undersized cords overheat and lose power. Replace extension cords if they become damaged. DO NOT use extension cords for 220V machinery.
14. **ALWAYS DISCONNECT FROM POWER SOURCE BEFORE SERVICING MACHINERY.** Make sure switch is in OFF position before reconnecting.
15. **MAINTAIN MACHINERY WITH CARE.** Keep blades sharp and clean for best and safest performance. Follow instructions for lubricating and changing accessories.
16. **MAKE SURE GUARDS ARE IN PLACE AND WORK CORRECTLY BEFORE USING MACHINERY.**
17. **REMOVE ADJUSTING KEYS AND WRENCHES.** Make a habit of checking for keys and adjusting wrenches before turning machinery **ON**.
18. **CHECK FOR DAMAGED PARTS BEFORE USING MACHINERY.** Check for binding and alignment of parts, broken parts, part mounting, loose bolts, and any other conditions that may affect machine operation. Repair or replace damaged parts.
19. **USE RECOMMENDED ACCESSORIES.** Refer to the instruction manual for recommended accessories. The use of improper accessories may cause risk of injury.
20. **DO NOT FORCE MACHINERY.** Work at the speed for which the machine or accessory was designed.
21. **SECURE WORKPIECE.** Use clamps or a vise to hold the workpiece when practical. A secured workpiece protects your hands and frees both hands to operate the machine.
22. **DO NOT OVERREACH.** Keep proper footing and balance at all times.
23. **MANY MACHINES WILL EJECT THE WORKPIECE TOWARD THE OPERATOR.** Know and avoid conditions that cause the workpiece to "kickback."
24. **ALLERGIC REACTIONS.** Be aware that certain metal shavings and cutting fluids may cause an allergic reaction in people and animals, especially when cutting fumes can be inhaled. Make sure you know what type of metal and cutting fluid you will be exposed to and how to avoid contamination.

WARNING

Additional Safety Instructions for Lathe/Mills

- 1. AVOID CRASHES.** Make sure no part of tool, tool holder, compound or cross slide, or carriage will come into contact with the chuck during operation.
- 2. PRE-START.** Before starting the machine be certain the workpiece has been properly engaged in the chuck and tailstock center (if in use) and that there is adequate clearance for full rotation.
- 3. HOLDING TOOLS.** Adjust tool holder to provide proper support for the turning tool you will be using. Test tool holder clearance by rotating workpiece by hand before turning lathe **ON**.
- 4. SPINDLE SPEEDS.** Select the spindle speed which is appropriate for the type of work and material. Allow the lathe/mill to gain its full speed before beginning a cut.
- 5. FEED RATE CHANGES.** Never change feed rate or spindle speeds while the lathe is in motion.
- 6. SPINDLE DIRECTION CHANGES.** Never reverse motor direction while the lathe/mill is in motion.
- 7. STOPPING SPINDLE.** DO NOT stop lathe using your hand against the workpiece or chuck.
- 8. BE ATTENTIVE.** DO NOT leave lathe/mill running unattended for any reason.
- 9. MACHINE CARE AND MAINTENANCE.** Never operate the lathe/mill with damaged or worn parts. Maintain your lathe/mill in proper working condition. Perform routine inspections and maintenance promptly when called for. Put away adjustment tools after use.
- 10. DISCONNECT POWER.** Make sure lathe/mill is turned **OFF**, disconnected from its power source and all moving parts have come to a complete stop before starting any inspection, adjustment, or maintenance procedure.
- 11. AVOIDING ENTANGLEMENT.** Keep loose clothing articles such as sleeves, belts or jewelry items away from the lathe and drill spindles.
- 12. CUTTING TOOLS.** Always use the proper cutting tools for the material you are turning, make certain they are sharp and that they are held firmly in the tool holder.
- 13. SAFE CHUCK HANDLING.** Always place a board or piece of plywood across the bedway when removing or installing chucks to avoid the possibility of a finger pinch occurring between a loose chuck and the edges of the bedway.
- 14. CLEAN-UP.** DO NOT clear chips by hand. Use a brush, and never clear chips while the lathe is turning.

WARNING

Like all machines there is danger associated with the Model G9729. Accidents are frequently caused by lack of familiarity or failure to pay attention. Use this machine with respect and caution to lessen the possibility of operator injury. If normal safety precautions are overlooked or ignored, serious personal injury may occur.

CAUTION

No list of safety guidelines can be complete. Every shop environment is different. Always consider safety first, as it applies to your individual working conditions. Use this and other machinery with caution and respect. Failure to do so could result in serious personal injury, damage to equipment, or poor work results.

Glossary Of Terms

The following is a list of common definitions, terms and phrases used throughout this manual as they relate to this lathe/mill and metalworking in general. Become familiar with these terms for assembling, adjusting or operating this machine. Your safety is **VERY** important to us at Grizzly!

Arbor: A machine shaft that supports a cutting tool.

Backlash: Wear in a screw or gear mechanism that may result in slippage, vibration, and loss of tolerance.

Collet: A conical shaped split-sleeve bushing which holds round or rectangular tool and/or workpieces by their outside diameter.

Cross Feed: Mill—The movement of the table toward or away from the column.
Lathe—Movement of cutting tool across the end of the workpiece.

Cross Slide: A fixture attached to the lathe carriage that holds the compound rest and can be moved in and out.

Cutting Speed: The distance a point on a cutter moves in one minute, expressed in meters or feet per minute.

Dial Indicator: An instrument used in setup and inspection work that shows on a dial the amount of error in size or alignment of a part.

Dividing Head: A milling machine accessory used to divide a circular object into a number of equal parts.

Down Milling or Climb Milling: Feeding the workpiece in the same direction as the cutter rotation.

End Mill: A cutter with cutting surfaces on both its circumference and end.

Facing: In lathe work, cutting across the end of a workpiece, usually to machine a flat surface.

Feed: The movement of a cutting tool into a workpiece.

Fixture: A device that securely holds the workpiece in place during cutting operation as opposed to a **Jig** which is used to hold and guide a workpiece through an operation.

Gib: A tapered wedge located along a sliding member to take up wear or to ensure a proper fit.

Headstock: The major lathe component that houses the spindle and motor drive system to turn the workpiece.

Lathe Center: A lathe accessory with a 60° point which is inserted into the headstock or tailstock of the lathe and is used to support the workpiece.

Leadscrew: Lathe—The long screw that is driven by the end gears and supplies power to the carriage. Mill—The screws that move the table in longitudinal, transverse, or vertical directions.

Spindle: The revolving shaft that holds and drives the workpiece or cutting tool.

Tailstock: A moveable fixture opposite of the headstock on a lathe that has a spindle used to support one end of a workpiece and for holding tools.

Toolpost: The part of the compound rest that holds the tool holder.

Turret: Lathe—A machine fixture that holds multiple tools and can be revolved and indexed to position. Mill—The part of a mill which rotates on the column and can be set to a specific degree.

Ways: The precision machined and flat tracks on a lathe or mill on which the carriage, tailstock, and the mill table and knee slide.

SECTION 2: CIRCUIT REQUIREMENTS

110V Operation

!WARNING

Serious personal injury could occur if you connect the machine to the power source before you have completed the set up process. **DO NOT** connect the machine to the power source until instructed to do so.

Amperage Draw

The two 3/4 HP motors on the Model G9729 will each draw the following amps:

Motor Load8.8 Amps

Circuit Requirements

Only connect your machine to a circuit that meets the requirements below. Always check to see if the wires and circuit breaker in your circuit are capable of handling the amperage draw from your machine, as well as any other machines that could be operating on the same circuit. If you are unsure, consult a qualified electrician.

Minimum Circuit Requirement..... 15 Amp

Plug Type

The Model G9729 is supplied with a 5-15 plug, similar to **Figure 2**.

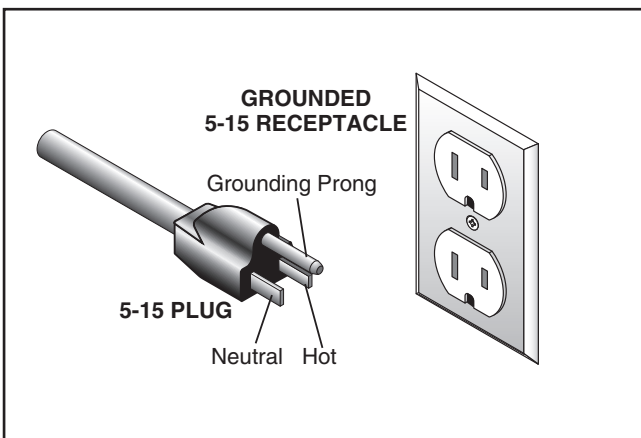

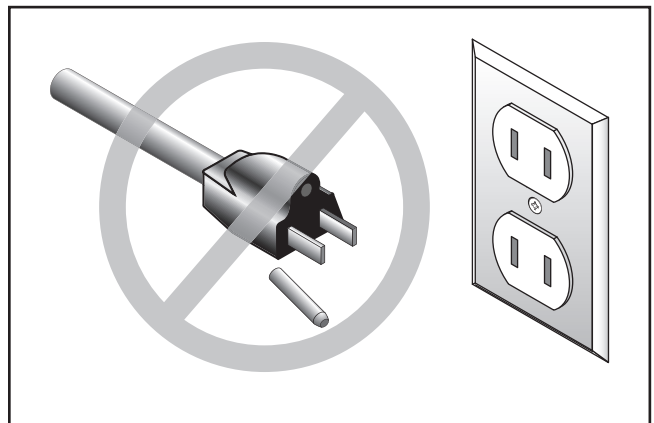

Figure 2. Typical 5-15 plug and receptacle.



!WARNING
Electrocution or fire could result if this machine is not grounded correctly or if your electrical configuration does not comply with local and state codes. Ensure compliance by checking with a qualified electrician!



!CAUTION
This machine must have a ground prong in the plug to help ensure that it is grounded. **DO NOT** remove ground prong from plug to fit into a two-pronged outlet! If the plug will not fit the outlet, have the proper outlet installed by a qualified electrician.

Extension Cords

- Make sure the cord is rated Standard Service (grade S) or better.
- The extension cord must contain a ground wire and plug pin.
- Use at least a 16 gauge cord. Use a 14 gauge cord if the cord is between 51-100 feet.
- Do not use extension cords over 100 feet.



SECTION 3: SET UP

Set Up Safety

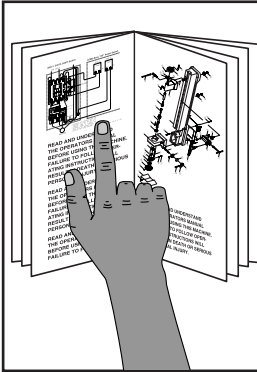

!WARNING

This machine presents serious injury hazards to untrained users. Read through this entire manual to become familiar with the controls and operations before starting the machine!

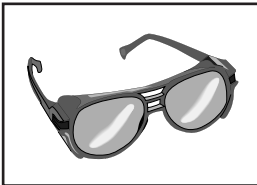

!WARNING

Wear safety glasses during the entire set up process!

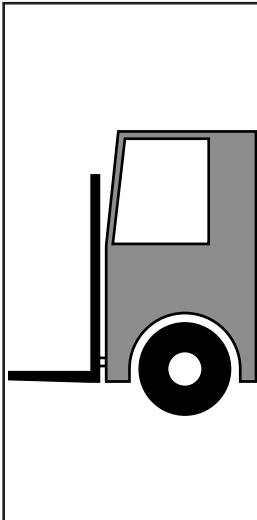

!WARNING

The Model G9729 has a shipping weight of approximately 692 lbs. Serious personal injury may occur if safe moving methods are not followed. To be safe, you will need assistance and power equipment when moving the shipping crate and removing the machine from the crate.



Items Needed For Set Up

The following items are needed to complete the set up process, but are not included with your machine:

Description	Qty
• Forklift (or other mechanical lifting device)	1
• An Assistant	1
• Safety Glasses (for each person)	1
• Precision Level	1
• Solvent for Cleaning	1
• Shop Rags	1
• Slings (rated for appropriate load)	1
• Steel Rod $\frac{3}{4}$ x 24"	2



Unpacking

The Model G9729 was carefully packed when it left our warehouse. If you discover the machine is damaged after you have signed for delivery, *please immediately call Customer Service at (570) 546-9663 for advice.*

Save the containers and all packing materials for possible inspection by the carrier or its agent. *Otherwise, filing a freight claim can be difficult.*

When you are completely satisfied with the condition of your shipment, you should inventory the contents.



Inventory

After all the parts have been removed from the two boxes, you should have the following items:

Box 1: (Figure 3)	Qty
A. Model G9729 Combo Lathe/Mill.....	1
B. Face Plate	1
C. Adaptor Plate.....	1

Small Box Contents:

D. 120T/127T Combo Gear, & 72T Gear	1
E. 36T Gear, & 33T Gear	1
F. 30T Gear, & 27T Gear	1
G. 60T Gear, & 48T Gear	1
H. 42T Gear, & 39T Gear	1
I. Plastic Spindle Cover	1
J. Lathe Chuck Jaws	1
K. Leadscrew Crank Handle	1
L. Wrench 13/16mm	1
Flat Head Screwdriver	1
Drift.....	1
Hex Wrench 3, 4, 5, & 8mm	4
M. MT#4 Dead Center.....	1
N. MT#3 Dead Center.....	1
O. Lathe Chuck Key	1
Tool Post Wrench.....	1
Shims	3
Drill Chuck Key.....	1

Item not shown:

P. Hex Handle 14mm for Head Lock.....	1
--	---

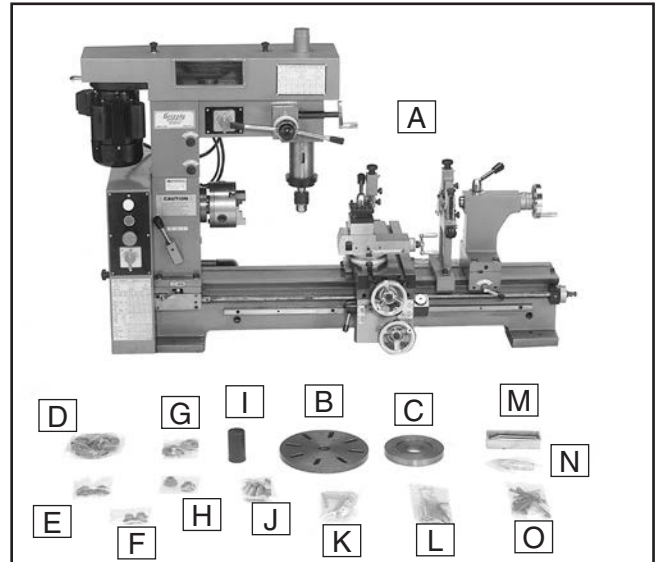

Figure 3. Model G9729 Inventory.

In the event that any nonproprietary parts are missing (e.g. a nut or a washer), we would be glad to replace them, or for the sake of expediency, replacements can be obtained at your local hardware store.



Hardware Recognition Chart

USE THIS CHART TO MATCH UP HARDWARE DURING THE ASSEMBLY PROCESS.

MEASURE BOLT DIAMETER BY PLACING INSIDE CIRCLE

- #10
- 1/4"
- 5/16"
- 3/8"
- 7/16"
- 1/2"



Key

- 4mm
- 5mm
- 6mm
- 8mm
- 10mm
- 12mm
- 16mm

LINES ARE 1MM APART

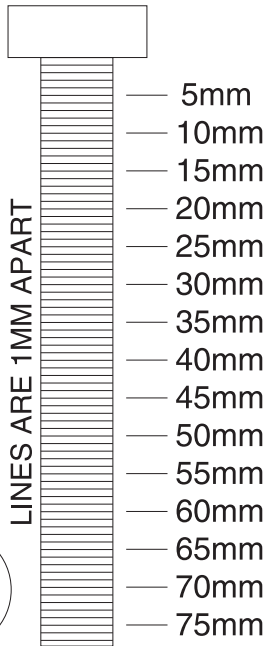

LINES ARE 1/16" INCH APART

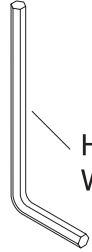
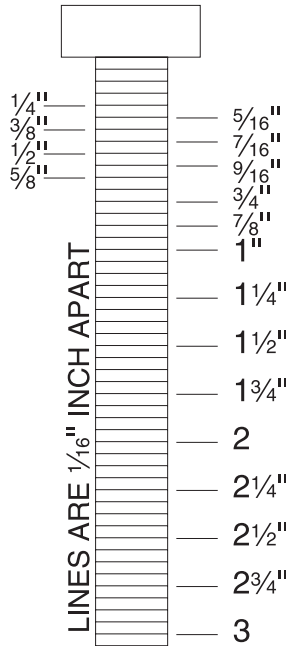

Hex Wrench

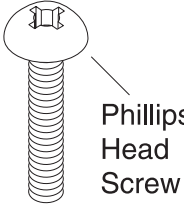

Phillips Head Screw

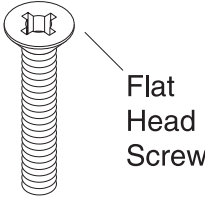

Flat Head Screw

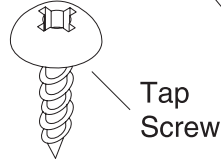

Tap Screw

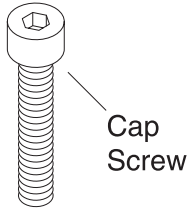

Cap Screw

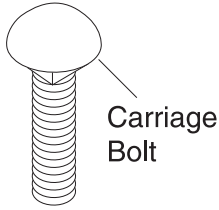

Carriage Bolt

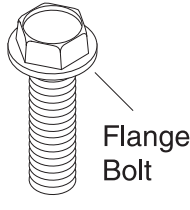

Flange Bolt

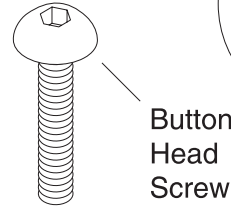

Button Head Screw

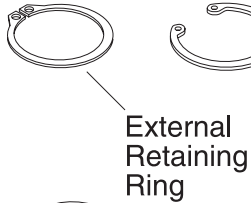

External Retaining Ring

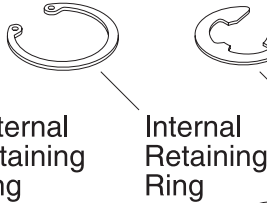

Internal Retaining Ring

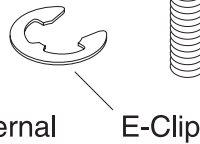

E-Clip

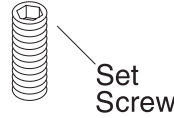

Set Screw

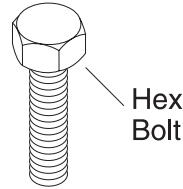

Hex Bolt



Lock Nut



Wing Nut

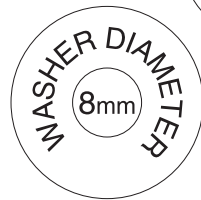
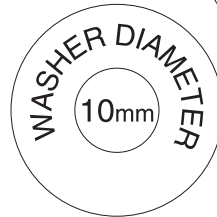
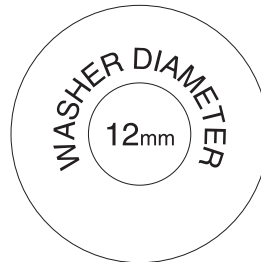
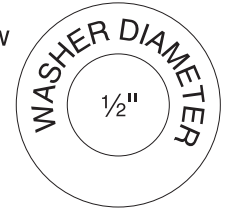
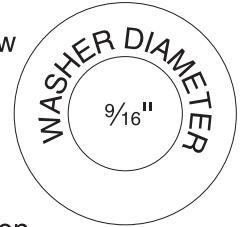
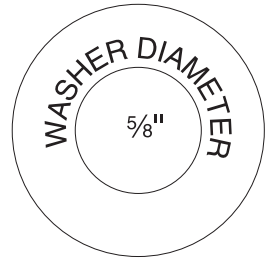

WASHERS ARE MEASURED BY THE INSIDE DIAMETER

Clean Up

The unpainted surfaces are coated with a waxy oil to protect them from corrosion during shipment. Remove this protective coating with a solvent cleaner or citrus-based degreaser such as Grizzly's G7895 Degreaser. To clean thoroughly, some parts may need to be removed. **For optimum performance from your machine, make sure you clean all moving parts or sliding contact surfaces that are coated.** Avoid chlorine-based solvents, such as acetone or brake parts cleaner, as they may damage painted surfaces should they come in contact. Always follow the manufacturer's instructions when using any type of cleaning product.

	<p>⚠️ WARNING Gasoline and petroleum products have low flash points and could cause an explosion or fire if used to clean machinery. DO NOT use gasoline or petroleum products to clean the machinery.</p>
--	--

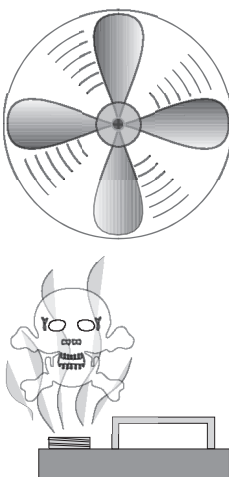
	<p>⚠️ CAUTION Many of the solvents commonly used to clean machinery can be toxic when inhaled or ingested. Lack of ventilation while using these solvents could cause serious personal health risks or fire. Take precautions from this hazard by only using cleaning solvents in a well ventilated area.</p>
---	--



Site Considerations

Floor and Workbench Load

Your Model G9729 weighs 525 lbs. Most commercial or garage shop floors should be sufficient to carry the weight. Before moving the Lathe/Mill onto a residential floor, inspect it carefully to determine that it will be sufficient to carry the load of the machine, the device for moving it and its operators. The workbench the machine rests on should be strong and stable enough to hold the weight of the machine and the workpiece.

Working Clearances

Consider existing and anticipated needs, size of material to be processed through each machine, and space for auxiliary stands, work tables or other machinery when establishing a location for your lathe/mill combo (see **Figure 4**).

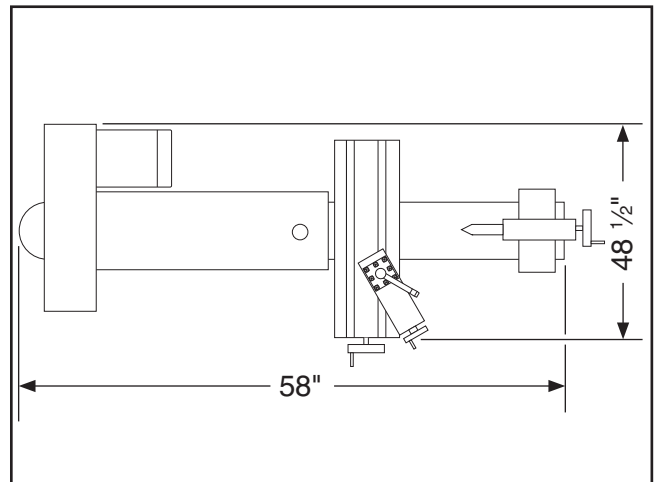

Figure 4. Working dimensions.

	<p>⚠️ CAUTION Unsupervised children and visitors inside your shop could cause serious personal injury to themselves. Lock all entrances to the shop when you are away and DO NOT allow unsupervised children or visitors in your shop at any time!</p>
--	--

Moving & Placing Base Unit

The Model G9729 requires the use of lifting equipment such as a fork lift, engine hoist or boom crane. DO NOT lift the machine by hand. Holes are provided in the edge of the lathe bed for inserting $\frac{3}{4}$ " steel rods for lifting (see **Figure 5**). Used in conjunction with lifting straps and following safe lifting procedures as detailed by the manufacturers of these lifting devices, the lathe/mill can be safely lifted off the pallet and placed on a sturdy work bench.

Practice safe lifting:

- Position the tailstock and apron to the far right on the lathe bed. (Opposite of the headstock.)
- Make sure the steel rods for lifting extend at least 8" on each side of the lathe bed.
- DO NOT lift the machine from any other points than the lifting holes provided.
- Use lifting equipment such as a fork lift, engine hoist or crane to move or lift the lathe/mill. **Never** use only human power to lift the machine.

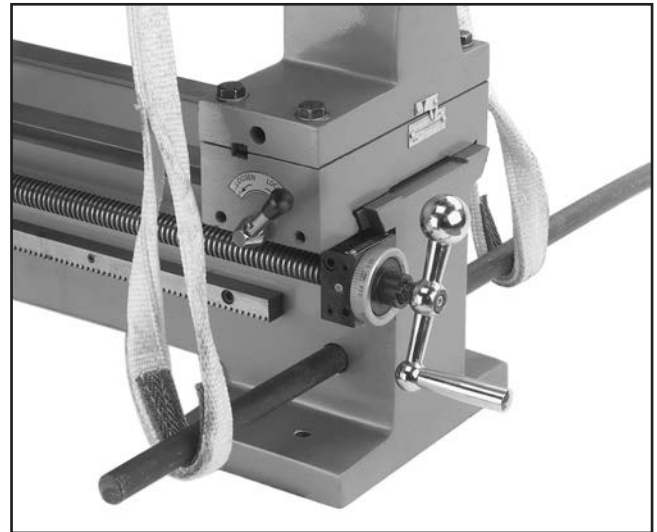
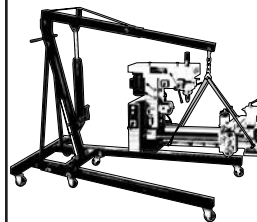

Figure 5. Use lifting straps, bars and power equipment to lift machine.



!WARNING

Wear safety glasses during the entire setup process!



!WARNING

The Model G9729 is a heavy machine, 525 lbs. DO NOT move the machine by yourself – you will need assistance and power equipment. Serious personal injury may occur if safe moving methods are not followed.



Hand Crank

The hand crank for the longitudinal manual feed must be installed.

To install the hand crank:

1. The end of the leadscrew has a washer and screw attached. Remove these.
2. The hand crank has a key slot on one side as shown in **Figure 6**. Slide the hand crank onto the end of the leadscrew, key slot first.
3. Thread the screw through the washer and into the end of the leadscrew.
4. To use the hand crank, push it in towards the leadscrew so the key way and key engage. Turn the hand crank while keeping pressure applied. When released, the hand crank will withdraw from the leadscrew and will no longer be engaged.

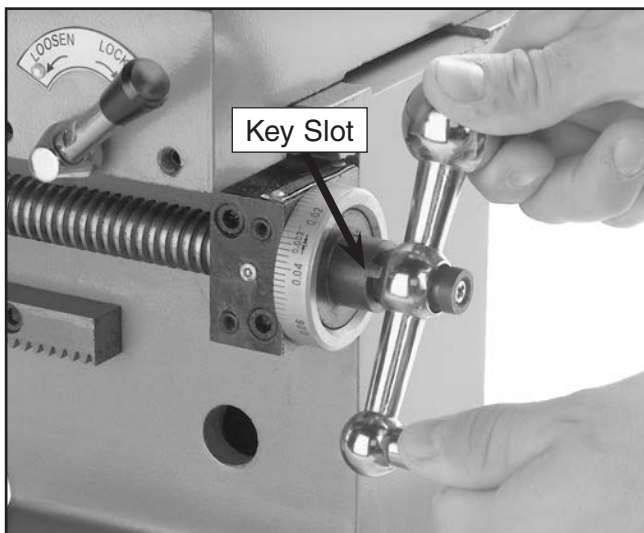

Figure 6. The key is engaged with the hand crank.



Handwheels

The apron and cross slide handwheel handles must be installed. A screwdriver is supplied for this job. Locate the threaded holes on each hand wheel and attach the handles (see **Figure 7**).



Figure 7. Attach handles to handwheels.



Steady and Follow Rest Removal

The Model G9729 Lathe/Mill comes equipped with a steady rest and follow rest. These are used to support smaller stock while turning, drilling or boring. They are installed at the factory for shipping purposes and should be removed at this time. The steady rest has a single clamp bolt that once removed, allows the clamp shoe to come out the side (**Figure 8**) and the main body to be lifted off of the lathe bed.

To remove the follow rest, simply remove the two cap screws at its base. We recommend threading the screws back into the mounting holes to keep the holes clear of debris and to make sure they do not become misplaced.

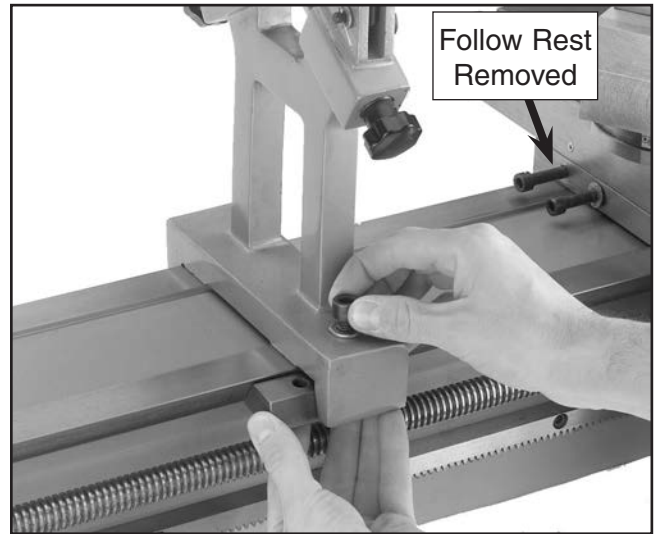
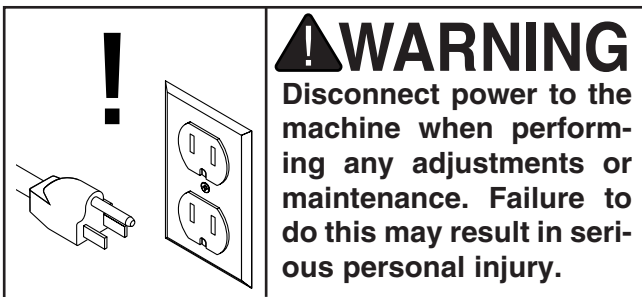

Figure 8. Removing the clamp shoe on the steady rest.



Test Run



Now that the lathe/mill is set up and you have read the safety guidelines, it's time to give each motor a test run.

The purpose of the test run is to make sure the lathe/mill is wired correctly and the motors are working properly before proceeding with additional set up. Check to make sure that auto feeds are not engaged, the chucks are secure in the spindles, and there are no loose parts around the spindles. Set the lathe/mill to the slowest RPM before the test run. Refer to **Control Panel** on **Page 19**, **Lathe Speeds** on **Page 34**, **Mill Speeds** on **Page 44**, and **Lubrication** on **Page 51** before doing the test run.

The lathe and mill motors will be tested independently. Before starting the lathe/mill:

1. Make sure the machine is properly grounded, the power switch is turned **OFF**, and both reversing switches are set to the middle position.
2. Inspect the machine to ensure that all hand tools are out of the way, guards are in place and nothing is impeding the movement of either chuck. Check this by rotating each by hand.
3. Rotate the EMERGENCY STOP button in the direction of the arrows on the button and allow it to pop out.
4. Push the START button on the control panel. While keeping your hand on the reversing switch for the lathe, turn it to the FORWARD position. The lathe should run smoothly with little or no vibration or rubbing noises when it starts. Strange or unnatural noises should be investigated and corrected before operating the machine further.
5. If the lathe/mill is running correctly, turn the reversing switch to the **OFF** position, wait for the machine to come to a complete stop.



SECTION 4: LATHE OPERATIONS

Operation Safety

!WARNING

Damage to your eyes, lungs, and ears could result from using this machine without proper protective gear. Always wear safety glasses, a respirator, and hearing protection when operating this machine.

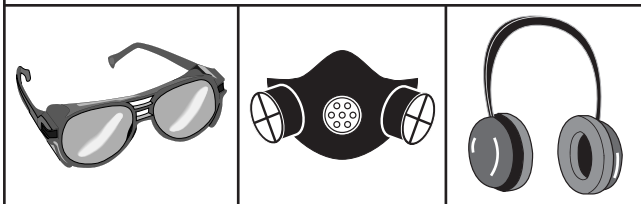

!WARNING

Loose hair and clothing could get caught in machinery and cause serious personal injury. Keep loose clothing and long hair away from moving machinery.

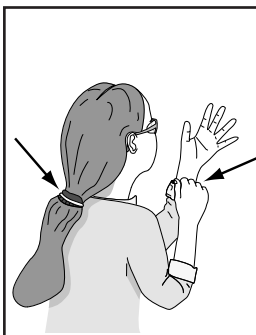

NOTICE

If you have never used this type of machine or equipment before, **WE STRONGLY RECOMMEND** that you read books, trade magazines, or get formal training before beginning any projects. Regardless of the content in this section, Grizzly Industrial will not be held liable for accidents caused by lack of training.



Control Panel

It is vital that you become familiar with the control panel before operating the Model G9729.

Power to the two motors is controlled through a series of switches mounted on the Lower and Upper Belt Guards in **Figure 9**. Please examine the layout before running the lathe/mill.

Note—*The lathe spindle and drill spindle cannot be used simultaneously.*

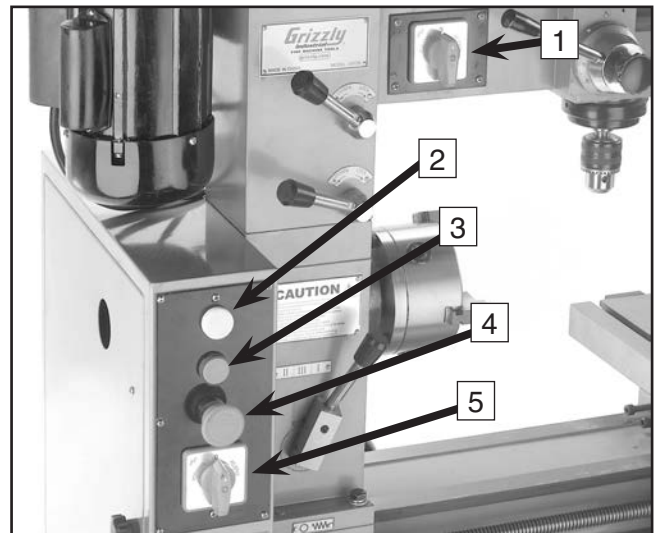
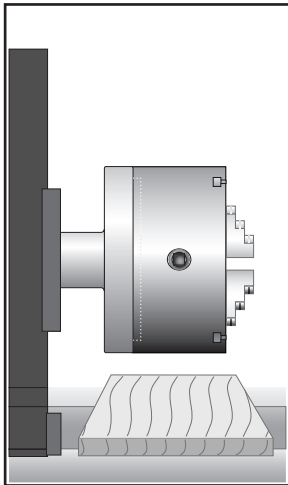

Figure 9. Control panel components.

1. **MILL REVERSING SWITCH:** select direction of rotation for the milling/drilling spindle.
2. **POWER INDICATOR LIGHT:** shines when the system power is **ON**.
3. **SYSTEM ON BUTTON:** push this button to get power to the system.
4. **EMERGENCY STOP BUTTON:** immediately disconnects power to the system. Once pressed, this button must be twisted to allow use of the system ON button.
5. **LATHE REVERSING SWITCH:** selects direction of rotation for the lathe spindle.

Lathe Chuck Removal



CAUTION

ALWAYS place a piece of plywood over the bed-ways of the lathe before removing or installing a lathe chuck. This helps by covering the sharp corners of the bed, protecting your hands and fingers from a pinch injury.

WARNING

Always disconnect the power to the machine before making adjustments, set-up changes or cleaning. Failure to do so could result in injury to yourself and others.

To remove a chuck:

1. **Unplug the lathe/mill!**
2. Place a piece of plywood or a chuck cradle across the lathe bed and position it just under the chuck. The board should be at least 8" wide and 10" long.
3. Locate the three socket head cap screws on the back of the back plate and remove two of them. (**Figure 10**).
4. Loosen the last screw, then tap the edge of the chuck with a rubber or wooden mallet to loosen the seal between the chuck and plate.
5. Remove the last screw and the chuck. Note—*Support the bottom of the chuck with a block or an assistant. It is important that you are ready to support its weight (35-50 lbs. depending on the chuck).*

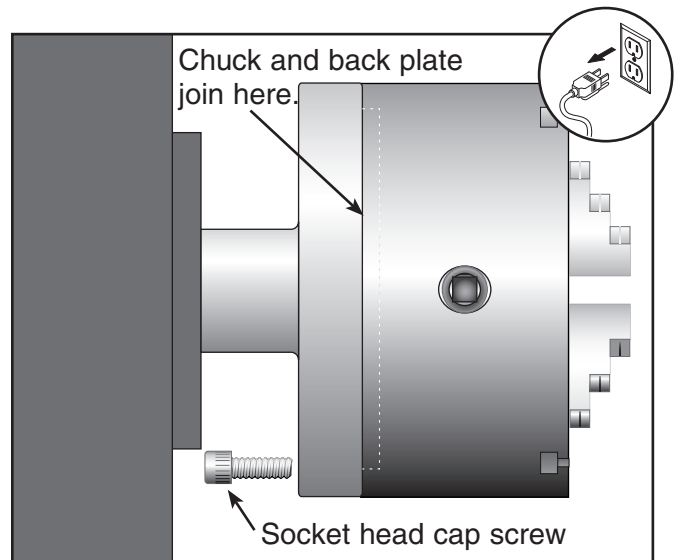

Figure 10. Removing screw from back of chuck.

To install a chuck:

1. **Unplug the lathe/mill!**
2. Place a piece of plywood across the lathe bed and position it just under the spindle.
3. Clean the mating surfaces with a paint brush or rag, then wipe the surfaces with your hand. If there is grit on the surfaces you will be able to feel it. Keep wiping until it is clean.
4. Place a socket head screw into one of the holes in the back plate. Lift the chuck up to the spindle and align the threaded hole in the back of the chuck with the screw.
5. While supporting the weight of the chuck, turn the screw three turns. **DO NOT** tighten at this time, just snug the screw a little bit. Rotate the spindle and repeat the steps on the last two screws.
6. Return to the first screw and tighten it a little more. Tighten the other screws also but only enough so the gap between the chuck and the back plate remains even.
7. Finally, tighten all three screws until the gap between the chuck and the back plate is closed and the screws are tight.



Lathe Chucks with Mounting Plate

The Model G9729 Lathe/Mill comes equipped with a 5" 3-jaw chuck (already installed).

The 3-jaw chuck is a scroll-type chuck, meaning that all three jaws move simultaneously when the chuck key is turned. Most 4-jaw chucks, on the other hand, feature jaws that are adjusted independently. A 4-jaw chuck can be used to hold square or rectangular stock and is used to "dial in" stock to true axial alignment. Rotate the chuck key clockwise, closing the jaws (**Figure 11**).

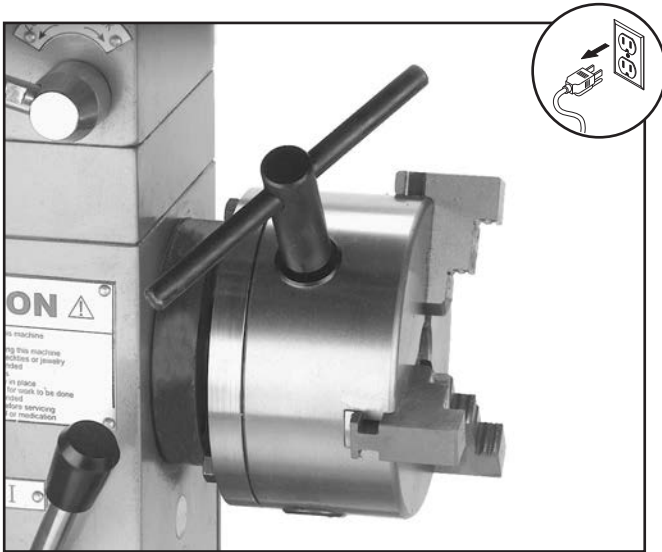

Figure 11. Rotate chuck key to close jaws.

Please note that an adapter plate has been provided for mounting a 4-jaw chuck. Please see Grizzly's current catalog for ordering information on 4-jaw chucks.

To use this adaptor plate:

1. Fasten the plate to the 4-jaw chuck using the screws provided with the chuck.
2. Fasten the plate to the spindle plate using the three screws that were removed from the 3-jaw chuck.

DO NOT mount chucks measuring larger than 6" in diameter on this spindle.

Some 4-jaw chucks may not readily mount to the back plate provided. It may be necessary to drill and tap new mounting holes and/or resurface and shoulder the plate so the chuck can be mounted accurately and safely. See **Replacing Jaws** on **Page 23**.



Chuck Jaws

The 3-jaw chuck supplied with the lathe/mill comes with 2 sets of jaws which are depicted in **Figure 12**. These are commonly known as the internal and external jaws. While both can hold a workpiece on the inside or outside surface of the jaw, the most common uses are shown in **Figure 13**.

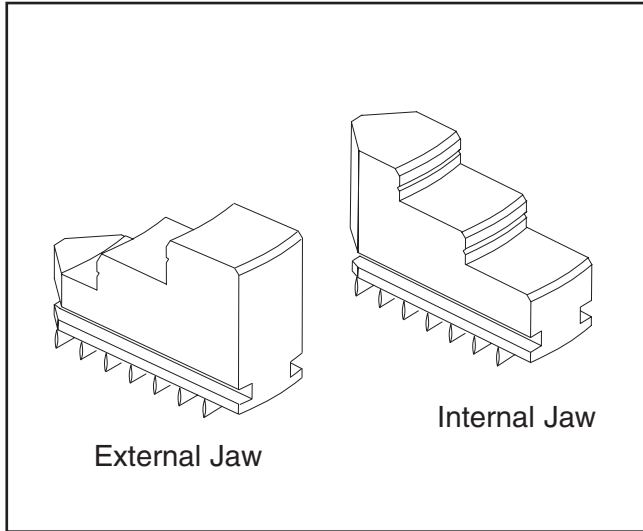

Figure 12. Jaws for the 3-jaw chuck.

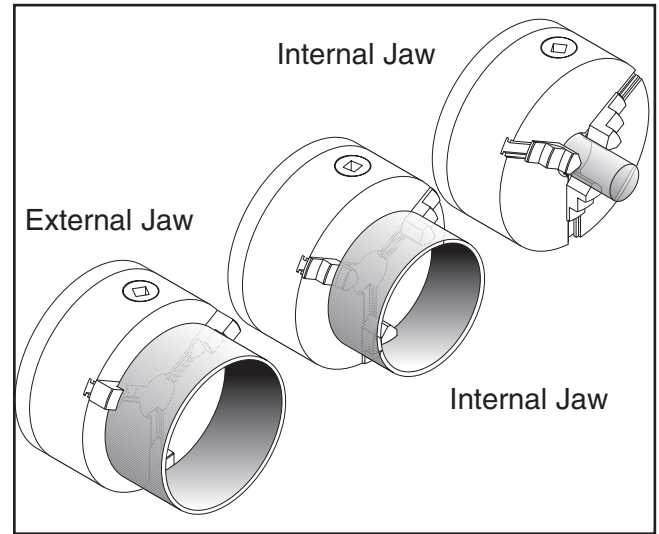

Figure 13. Workholding options.

Replacing Jaws

Changing jaws on the 3-jaw chuck is straight forward, but attention must be paid to the sequence in which the jaws are loaded into the chuck. Follow the instructions below.

!WARNING

Always disconnect the power to the machine before making adjustments, set-up changes or cleaning. Failure to do so could result in injury to yourself and others.

To replace the jaws:

1. **Unplug the lathe/mill!**
2. Remove all of the jaws on the chuck by turning the chuck key counterclockwise. Each jaw will move until it reaches the end of the lead thread of the scroll inside the chuck body. The jaws can then be pulled out of the chuck by hand.
3. Examine the inside of each slot in the chuck for debris and clean.
4. Examine each chuck jaw. Numbers can be found in the slot, at the bottom of each jaw.
5. Locate the slot and the jaw with the #1 and rotate the chuck key in the clockwise direction until you see the beginning of the lead thread on the scroll come into view through the slot, then back it off slightly until it disappears again. In **Figure 14**, the lead thread is still showing in the slot. The jaw cannot be loaded until the lead thread for the scroll is no longer seen in the slot.
6. Slide the #1 jaw into the slot and rotate the key clockwise a couple of turns.
7. Repeat **Step 5** for jaw #2 and #3 in sequence.



Figure 14. Arrow points to the lead of the scroll.

It is important to follow these points when replacing jaws in your 3-jaw chuck:

- The jaws must be loaded in sequence beginning with the #1 jaw.
- The chuck, scroll, and jaws should be thoroughly cleaned before assembly. (A paint brush works great for cleaning the scroll).
- Never use a combination of inside and outside jaws to hold a workpiece.
- DO NOT over-tighten the chuck jaws. Damage will occur, resulting in loss of accuracy.
- DO NOT load the jaws into chuck incorrectly to do eccentric work. Use a 4-jaw chuck for this purpose.
- 3-jaw chucks will always have a little runout. It is advisable to measure the runout of a workpiece after it is mounted in the chuck. If a higher degree of accuracy is desired, replace the 3-jaw chuck with a 4-jaw chuck and adjust the workpiece while using a dial indicator until the desired concentricity is achieved.



Face Plate

The face plate supplied with the model G9729 Lathe/Mill can be easily mounted to the spindle once the chuck has been removed. Installing the faceplate follows the same steps as any of the lathe chucks. In **Figure 15** the face plate is being set up to hold a workpiece for precision boring. Always use a minimum of 3 independent clamps when holding eccentric workpieces.

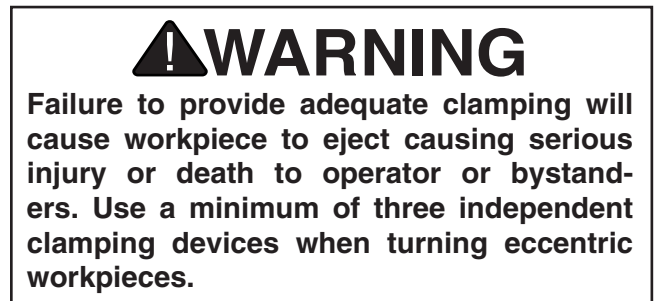
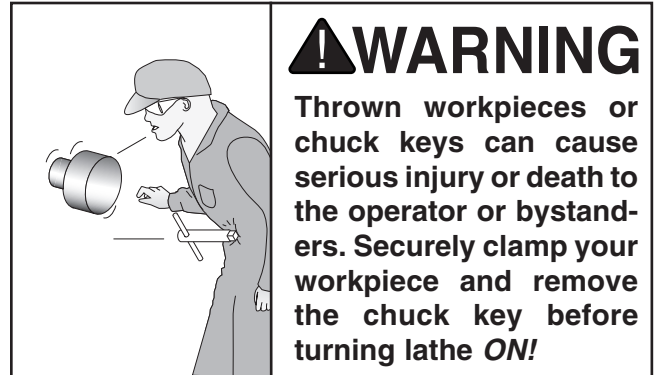

Figure 15. Setting up face plate.

To load a workpiece:

1. **Unplug the lathe/mill!**
2. Support the workpiece.
3. Lock the tailstock and then turn the tailstock quill so the dead center makes contact with the centerpoint of your workpiece.
4. Lock the tailstock and apply sufficient pressure to hold the workpiece in place. Depending on the workpiece, some additional support may be needed.
5. Secure the workpiece with a minimum of three independent clamping devices. Failure to follow this step may lead to deadly injury to yourself or bystanders. Take into account rotation and the cutting forces applied to the workpiece when clamping to the faceplate. **Make sure your clamping application will not fail!**

6. Check your centerline, as tightening the clamps may have caused it to move. Adjust as necessary.
7. Use a lower RPM when machining heavy eccentric workpieces. Take into consideration workpiece size and material.



Dead Center

The dead center is used to support stock that is too long to be supported by the chuck alone. Stock protruding more than $2\frac{1}{2}$ times its diameter should be supported by a dead or live center.

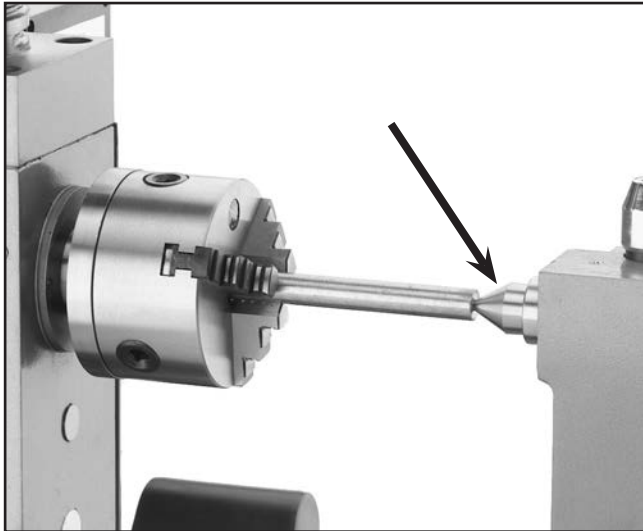
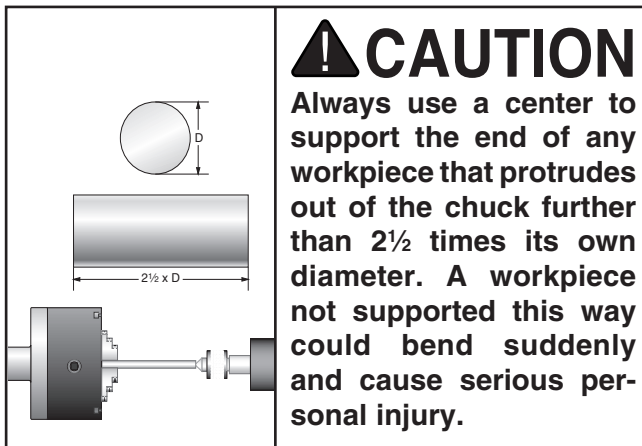

Figure 16. Dead center installed in tailstock.



The tailstock quill and the dead center have a Morse Taper #3. Before assembling these, ensure that the mating surfaces are very clean. Clean the mating surfaces so they are free of dirt and oil. These parts will last longer and remain accurate when properly cleaned before assembly. Morse tapers will not interlock when dirt or oil are present on the mounting surfaces.

Insert the end of the dead center into the tailstock bore until it seats. The force of the dead center contacting a mounted workpiece will fully seat the taper when the handwheel is tightened.

When using a center, the tailstock quill should protrude about $\frac{1}{2}$ " and not more than $1\frac{1}{4}$ " out of the tailstock body (Figure 16).

To minimize wear and maximize smooth operation, oil the tip of the dead center before seating it in the workpiece as in Figure 17. Heat from friction will reduce the life expectancy of the center, and may cause chatter in the workpiece and spoil the center hole.

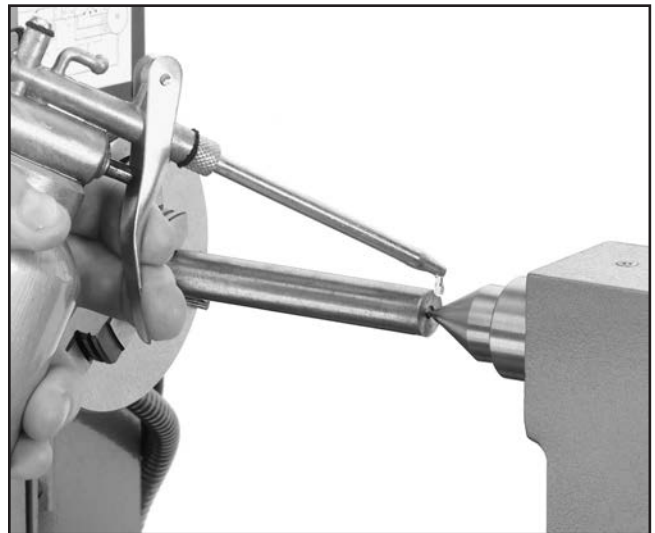

Figure 17. Oil center hole before seating the dead center.

To remove the dead center, back the tailstock quill all the way into the tailstock casting by turning the handwheel counterclockwise. The dead center will pop out. Be sure to hold it before it comes out, preventing the dead center from falling and causing any damage to the lathe or the dead center.

The dead center is used with the idea of achieving a more accurate finished product while keeping the spindle RPM low. Failure to do this will burn up the dead center. For a slight bit of accuracy loss and large gain in time, the live center can be used. The live center has bearings letting the center and the workpiece rotate together, instead of the workpiece rotating around the dead center.



Tool Post

The Model G9729 comes supplied with a 4-way turret tool post that is designed to accept up to four ½" tool bits. Other devices and holders may be installed into the tool post and arranged as in **Figure 18**.

- When more than one tool is secured into the tool post, changing from one tool to another is quickly done by loosening the lock lever (#4) and rotating the post to the desired tool.
- A spring-loaded catch is installed below the tool post and allows motion in only one direction. The catch causes the tool post to stop at the same rotational point for each tool placement. This feature can be useful for some types of machining setups. Note— *Securing the tool post is not dependent upon the catch. Thus, the tool post can be positioned at any rotational location and properly fixed with the lock lever. Also, removing the catch and rotating it 180° will cause the tool post to stop in the opposite direction.*

When securing a tool bit into the tool post, always remember these rules:

- Secure the tool bit with at least two of the bolts on the tool post.
- Make sure the top of the tool bit is at the lathe spindle center line or just below. The tailstock center can be used as a reference as shown in **Figure 19**.
- Never extend the tool bit more than 2½ times its thickness from the edge of the tool rest. I.e. a ⅜" tool bit should only extend ⅝" past the bottom of the tool rest. Less is better!
- Always use sharp tool bits.
- Avoid using tool bits that require shimming. If you must, be sure to use steel shims as opposed to aluminum or brass shims. Soft shims may give, allowing the tool bit to become loose! Soft shims will also contribute to poor surface finishes.

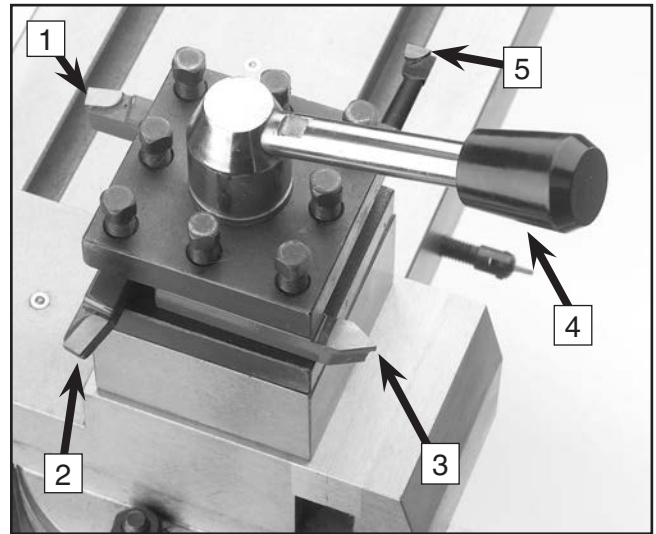

Figure 18. Four cutting tools mounted into the tool post shown with lock lever.

1. Left Hand Tool
2. Right Hand Tool
3. Threading Tool
4. Lock Lever
5. Boring Bar

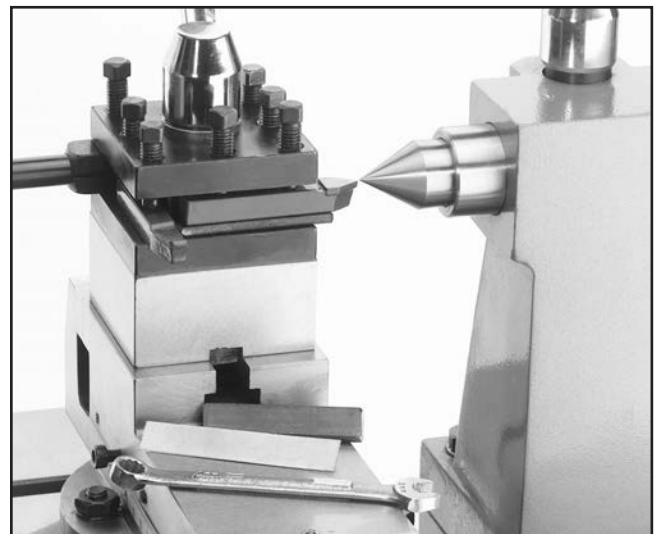

Figure 19. Using a center to check tool bit height.



Tailstock Controls

Figure 20 shows the locations of the tailstock controls.

1. Tailstock Handwheel

Turning the handwheel advances or retracts the quill in the tailstock. The graduated dial on the handwheel is adjustable.

2. Quill Lock Lever

This lever locks the tailstock quill in place.

3. Tailstock Lock Lever

This lever locks the tailstock in place on the lathe bed.

4. Offset Mechanism

Loosening these bolts allows the tailstock to be offset from center by turning a screw. This feature will allow taper turning when a workpiece is held between centers.

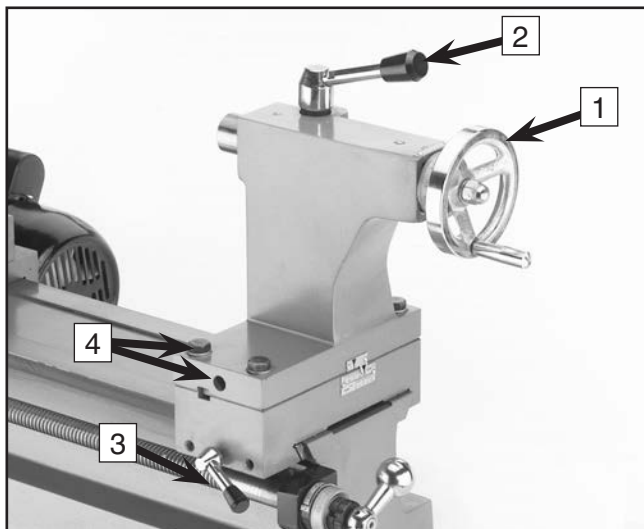

Figure 20. Detail of tailstock controls.



Tailstock

The tailstock on the Model G9729 is aligned with the headstock at the factory. However, we recommended that you take the time to ensure that the tailstock is aligned to your own desired tolerances.

To align the tailstock:

1. Center drill a 6" long piece of round cold rolled stock on both ends. Set it aside for use in **Step 4**.
2. Make a dead center by turning a 60° point on a piece of scrap material (**Figure 21**). Note— *As long as it remains in the chuck, the point of your new center will be accurate to your spindle axis. Keep in mind the point will have to be refinished whenever it is removed and returned to the chuck.*

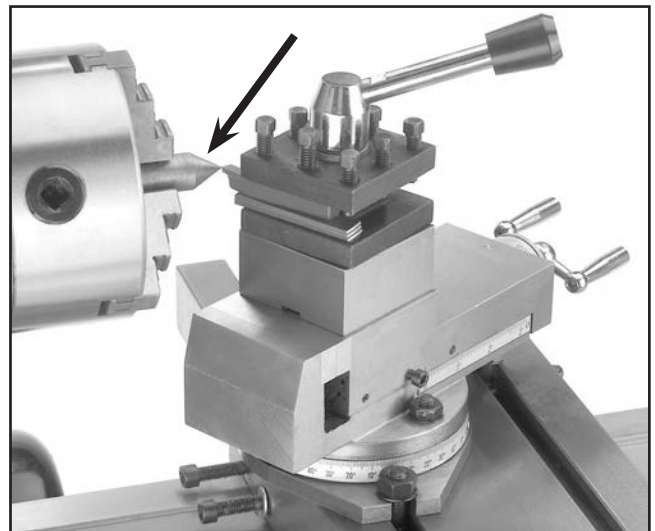

Figure 21. Finished dead center.

3. Place a center in your tailstock.
4. Attach a lathe dog to the bar stock and mount it between the centers (**Figure 22**).
5. Turn approximately .010" off of the diameter.

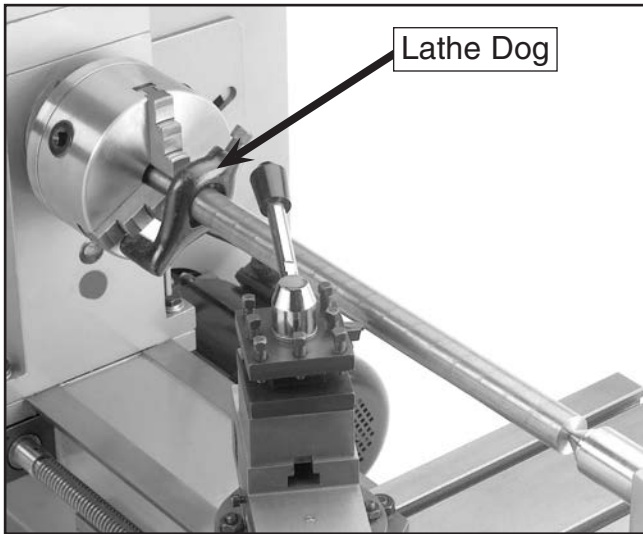

Figure 22. Bar stock mounted between centers with lathe dog.

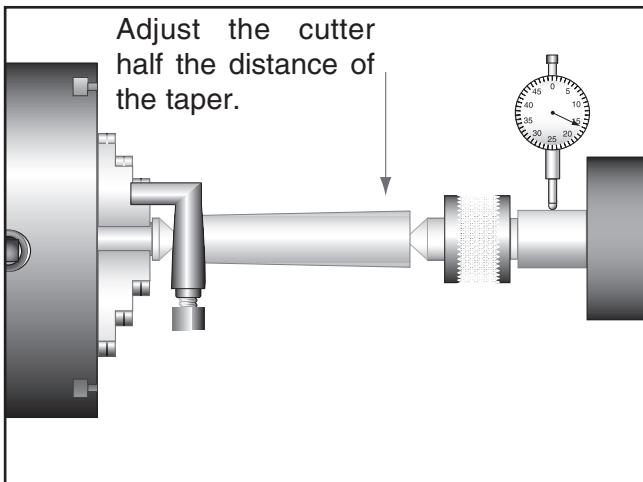

Figure 23. Adjusting for headstock end taper.

6. Measure the workpiece with a micrometer. If the stock is fat at the tailstock end, the tailstock needs to be moved toward the operator half the amount of the taper (**Figure 23**). If the stock is thinner at the tailstock end, the tailstock needs to be moved away from the operator by at least half the amount of the taper (**Figure 24**).

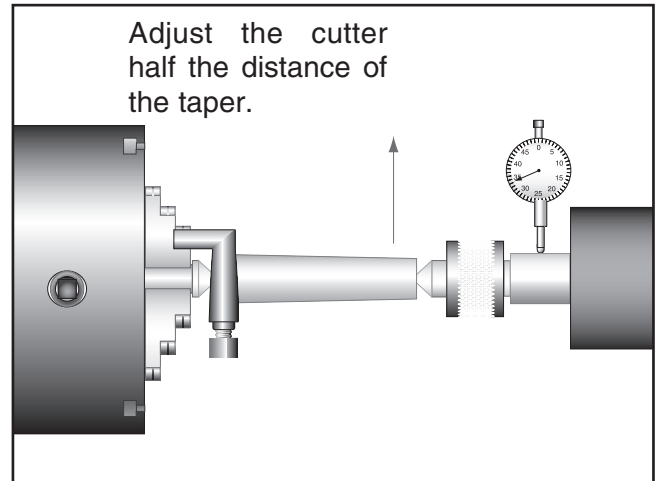

Figure 24. Adjusting for tailstock end taper.

7. Loosen the four tailstock mounting bolts. Adjust the tailstock offset by half the amount of the taper by turning the adjustment set screws (**Figure 25**). Turn another .010" off of the stock and check for a taper. Repeat as necessary until the desired amount of accuracy is achieved.

NOTICE
DO NOT forget to lock down the tailstock after each adjustment. Failure to follow this notice may cause damage to the tailstock, workpiece or both.



Figure 25. Tailstock offset adjustment screw.



Tailstock Drill Mounting

Prior to mounting the drill chuck into the tailstock, wipe the inside of the tailstock quill and arbor down with a clean dry cloth and inspect them for nicks or scratches. Any irregularities on the surface of the arbor or inside the tailstock quill will hinder the locking capability of the taper and should be dressed smooth with a fine file. Then wipe down with your hand to finish the cleaning process.

To mount the drill chuck into the tailstock of the lathe, slide the arbor into the tailstock quill about one half of the way. This should seat it well into the tailstock quill.



Tailstock Drill Removal

Because the drill chuck arbor is threaded on the small end, removal requires the use of a mallet and a wooden dowel as shown in **Figure 26**. Tap along the back edge of the drill chuck on the left and then the right. The drill chuck and arbor will pop loose from the tailstock quill.

Drill chuck arbors with a standard tang (or flat key) on the small end of the taper allow the operator to simply turn the tailstock handwheel counterclockwise until the drill chuck arbor pops loose. Grizzly offers a variety of chucks and arbors. Please see our current catalog for more information.



Figure 26. Removing the drill chuck.



Carriage Controls

The lathe has 3 handles for manual control of the tool bit during machining operations.

Compound Slide

This slide is adjustable so that cuts may be produced with an angle. By loosening the bolts at the swivel base as shown in **Figure 27**, the compound may pivot to any angle relative to the turning axis of the lathe spindle. This feature allows tapered cuts to be produced on a workpiece.

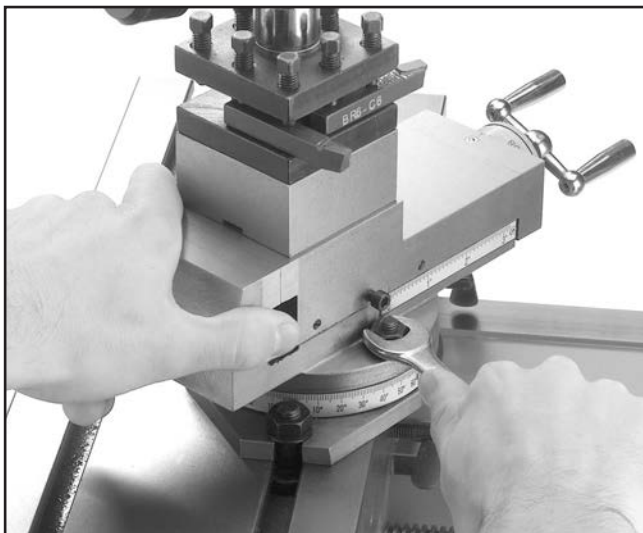

Figure 27. Changing the angle on the compound slide.

Cross Slide

This handwheel moves the compound slide across the lathe bed (see **Figure 28**). Turning the dial clockwise moves the slide away from the operator. The motion of this slide is used for facing a workpiece and when advancing a cut for reducing a diameter. The dial has 100 divisions with each mark representing 0.001" (one thousandths of an inch) of motion for the slide. The label above the dial reports that each line represents 0.002" \varnothing . It is best to think of this as the amount of reduction in diameter on the part, per mark on the dial. Therefore, rotating the dial 10 marks will move the slide 0.010", and multiplying this amount by 0.002" equals 0.020". The workpiece diameter will be reduced by 0.020".

Apron

The longitudinal motion of the apron is controlled by the lower handwheel (**Figure 28**) on the face of the apron or the hand crank at the end of the lathe bed. The handwheel will be used most often, but when the hand crank is used, remember that the half nut must be engaged and the crank must be pushed in before it will move the apron. The motion of this slide is used when cutting along the length of a workpiece. This slide can also be operated with the power feed feature.

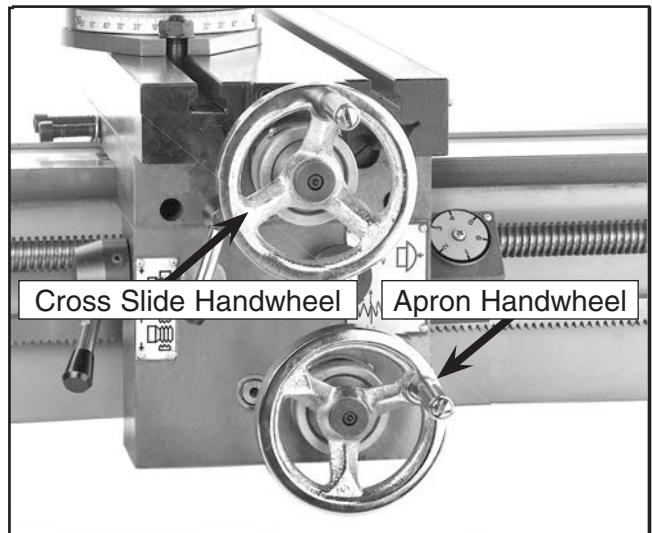

Figure 28. Carriage handwheels.

Graduated Dials

Each dial can be rotated without turning the hand crank. This is helpful because the dial can be set to zero after the tool bit touches the part. The graduated dial can be adjusted by holding the hand crank with one hand and turning the dial with the other.



Carriage Lock

The carriage lock lever is located under the right hand side of the apron as shown in **Figure 29**. This allows the carriage to be locked in place for precision facing operations while using the lathe or to make a set up in a milling operation more rigid.

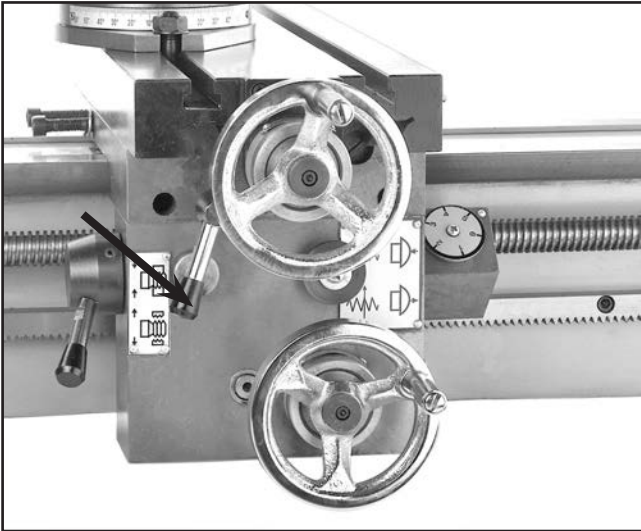

Figure 29. Carriage lock.



Follow Rest

The follow rest is used on long narrow stock to help keep deflection to a minimum. In normal use, the cutter applies some pressure to the part. In the case of slender parts (even those supported by a center mounted in the tailstock) there is a tendency for the part to deflect away from the cutter. The follow rest keep this from happening because the brass fingers support the workpiece near the point of contact with the cutter. **Figure 30** shows an example of follow rest use.

NOTICE

The workpiece must be supported with a center mounted in the tailstock when using the follow rest! Damage to the tool post, follow rest, and workpiece may occur if this notice is ignored.

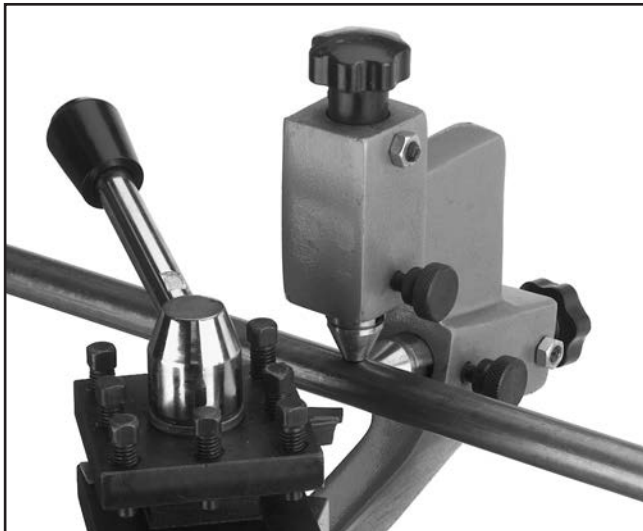

Figure 30. Follow rest set-up.

1. Attach the follow rest to the leading edge of the carriage.
2. Loosen the knurled thumb screws for each brass finger and turn the adjusting knobs clockwise until they stop.
3. Secure the workpiece between centers or into a 3- or 4-jaw chuck with a center mounted in the tailstock.

4. Lubricate the brass finger surfaces with oil prior to seating them on the workpiece and occasionally during use.
5. Adjust the brass fingers until they lightly touch the workpiece. Note—*To minimize deflection of the part during set up, use the method shown in (Figure 31). The indicator is set opposite to one of the brass fingers and the brass finger is adjusted until the needle on the dial moves, then it is backed off to the original setting. Each brass finger is adjusted this way.*

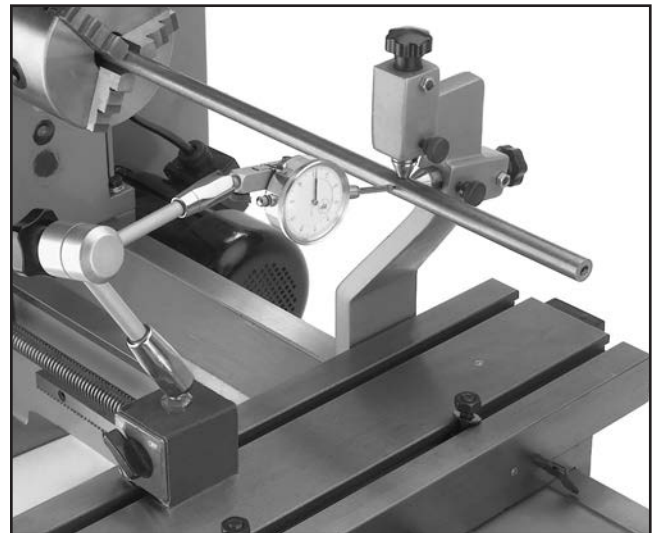

Figure 31. Setting the brass finger with an indicator.



Steady Rest

The steady rest is used for the same reasons as the follow rest and also when support is needed for a workpiece that cannot be supported by a center in the tailstock. This is especially useful when the end of a long workpiece is to be faced (**Figure 32**).

1. Place the steady rest on the lathe bed on one side of the apron or the other. If the end is to be faced, the steady rest is placed on the left hand side of the apron.
2. Place the clamp shoe in position and secure with the cap screw. (Refer to **Figure 8** on **Page 17**.)

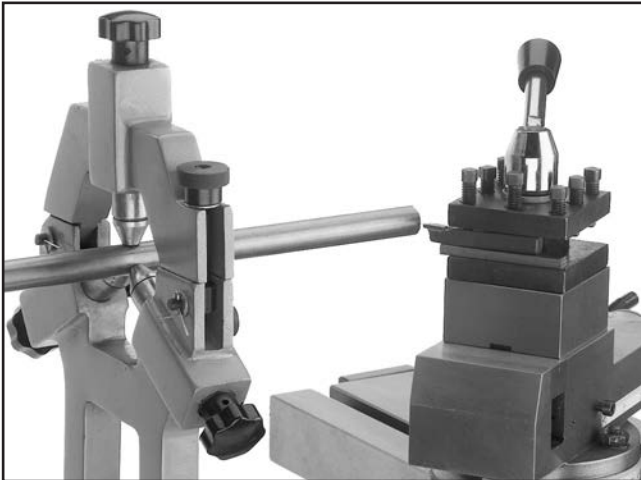

Figure 32. Steady rest supporting a part to be faced.

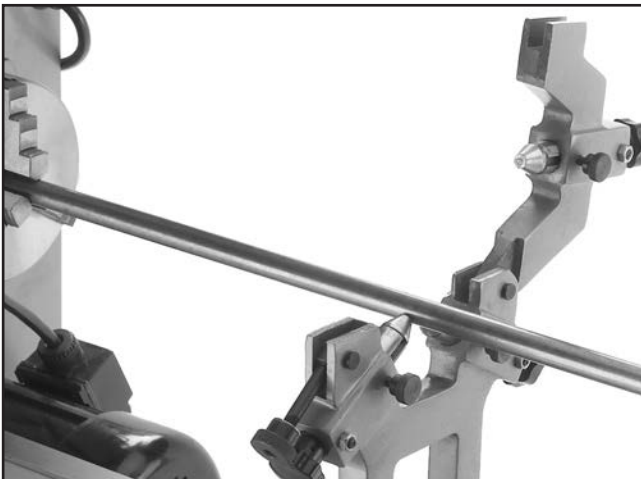

Figure 33. Loading the workpiece into the steady rest.

3. Loosen the thumb screws for each brass finger and adjust the brass fingers to allow plenty of clearance for the workpiece.
4. Loosen the knurled thumb wheel, and pivot the head out of the way (see **Figure 33**).
5. Load the workpiece into the chuck.
6. Oil each brass finger and pivot the head back into place and secure with the lock bolt.
7. Adjust the brass fingers until they lightly touch the workpiece.
8. Use the indicator as described in **Follow Rest** on **Page 32** to set the brass finger in the proper position.



Lathe Speeds

The speed of the lathe is controlled by the positions of the belts on the pulleys. The chart in **Figure 34** shows the various combinations of belt positions for achieving a range of six speeds.

⚠ WARNING

Always disconnect the power to the machine before making adjustments, set-up changes or cleaning. Failure to do so could result in injury to yourself and others.

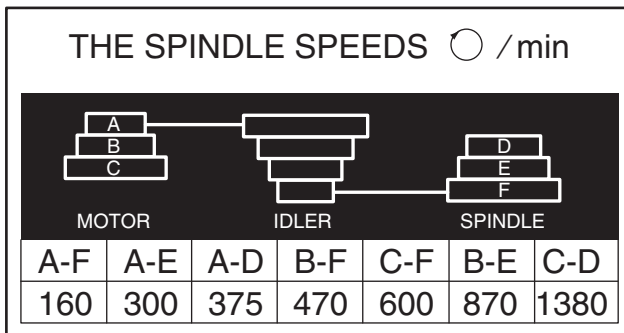

Figure 34. Lathe speed chart.

Example:

To select a spindle speed of 160 RPM, refer to **Figure 34**.

To change belt position:

1. **Unplug the lathe/mill!**
2. Loosen the tensioning lock lever on the back of the lower belt guard (see **Figure 35**).
3. Allow the middle pulley and the shaft it is mounted on, to slide downward along the slot on the back of the belt guard. This will relax the tension of the V-belts.

4. Move the V-belts to the A and F positions.
5. Pull the middle pulley and shaft back up the slot to tension the V-belts.
6. Tighten the lock lever.

Check the tension of the V-belts. They should deflect $\frac{1}{2}$ " with moderate finger pressure applied half way between the pulleys. If more deflection is present, re-tension the V-belts as in **Step 5**. DO NOT over tension the V-belts. Frequent over tensioning will result in premature bearing wear.

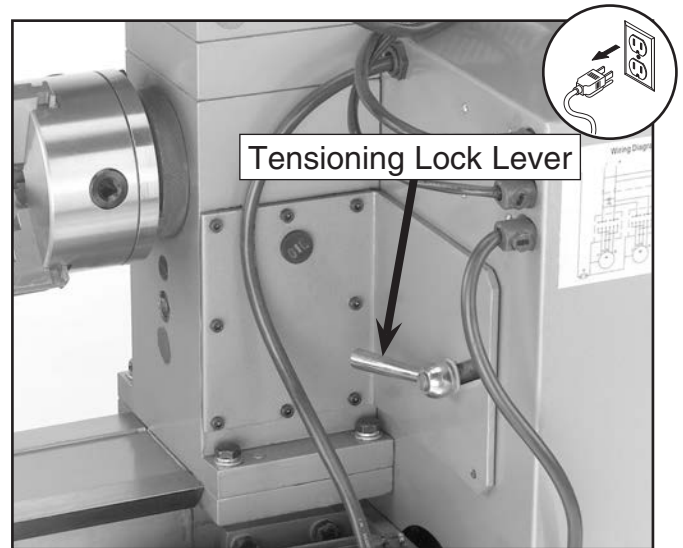

Figure 35. Lock lever to adjust pulley.



Start Up and Spindle Break-in Procedures

It is essential to closely follow the proper break-in procedures to ensure trouble free performance. Complete this process once you have familiarized yourself with all instructions in this manual.

To begin the start up and break-in procedure:

1. Check oil levels in the headstock and apron. Follow all lubrication procedures highlighted in **Lubrication** in the **MAINTENANCE** section on **Page 51** of this manual.
2. Make sure there are no obstructions around or underneath the spindle.
3. Turn the spindle ON/OFF switch to either the **FORWARD** or **REVERSE** position and verify the spindle rotates in the proper direction.
4. Set the spindle speed to the lowest RPM, refer to **Lathe Speeds** and **Mill Speeds** sections on **Pages 34 & 44**.
5. Turn the lathe **ON** and let it run for a minimum of 10 minutes.
6. Turn the lathe **OFF**, change gears to the next highest RPM and repeat this step for each RPM setting.
7. Repeat these steps for the mill.
8. Start with the slowest RPM and change V-belts to the next highest RPM and repeat this step for each RPM setting.

NOTICE

Failure to follow start up and spindle break-in procedures will likely cause rapid deterioration of spindle and other related parts.

Check all oil levels and lubrication points before starting lathe. Excessive wear will result if moving parts are not lubricated!

Feed Lever

The feed lever allows the power feeding feature of the lathe to be turned **ON** and **OFF**. When turned to the right, as in **Figure 36**, the feed lever engages power to the leadscrew, providing power to the apron and cross slide. When turned to the left, the lever disengages the power feed, enabling the apron to be fed manually with the hand crank at the end of the lathe bed. The hand crank cannot be turned manually unless the feed lever is turned to the left.

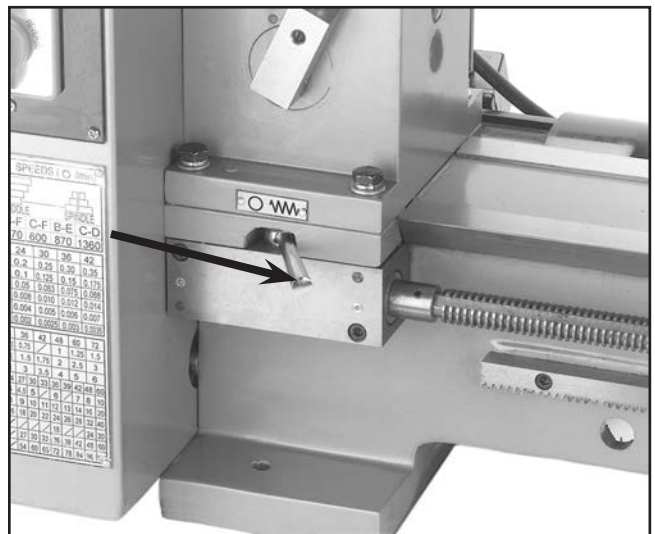
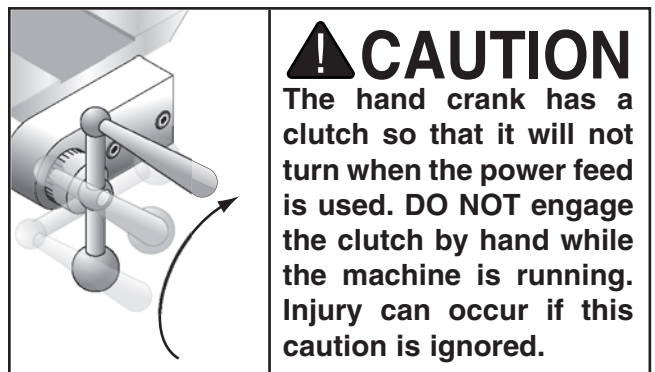

Figure 36. Feed lever indicated by arrow.



Feed Selection

NOTICE

Never move the feed rate lever while machine is running. Damage to the machine will occur.

NOTICE

DO NOT force any lever on this machine. If the lever will not engage, with the machine OFF, rotate the chuck by hand while keeping light pressure on the selector. As the chuck rotates it aligns the gear teeth inside the selector box and as the gears come to engage the selector will engage.

The Feed Rate selection Lever, shown in **Figure 37**, controls internal gears that change the feed rate. The coarsest setting for the feed rate lever is in the “I” position. When the lever is turned to the “II” position, the feed rate is reduced by one half of the feed rate of position “I”. When this lever is turned to the “III” position, the feed rate is reduced by one half the feed rate of position “II”. In position “I”, roughing would most likely be done and in the “III” position, finishing would most likely be done.

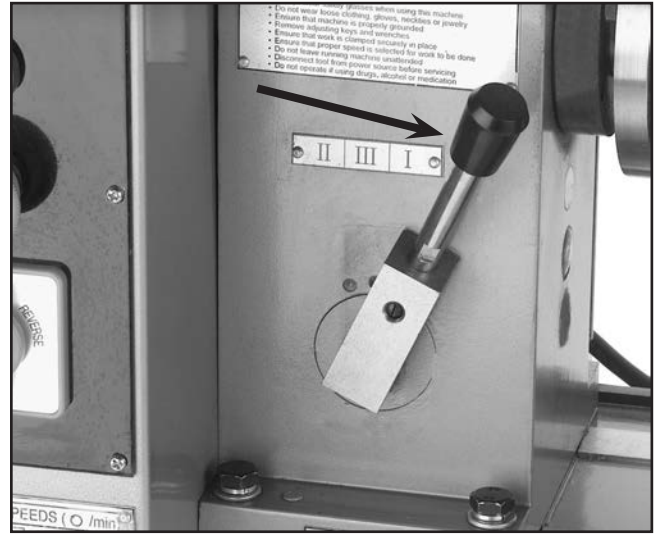

Figure 37. Feed rate selection lever.



Reading the Charts

Charts for the powerfeed and thread cutting features for the lathe are located on the bottom of the lower belt guard. **Figure 38** shows a segment of the chart for feed rates with a brief description.

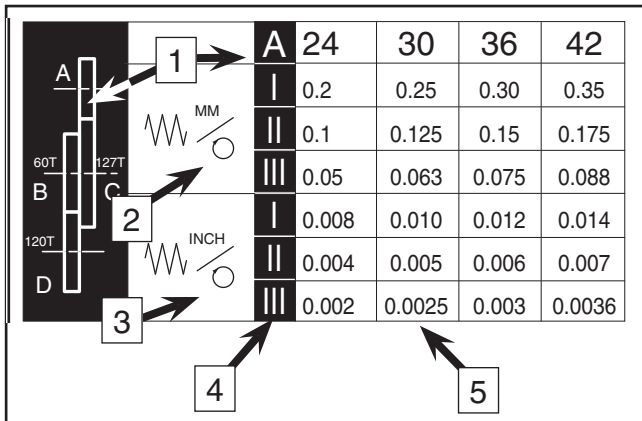

Figure 38. Rates given in millimeters and inches.

Note—These charts reflect approximate apron movement per revolution of the leadscrew.

1. Gear position A and the gears needed to accomplish the available feed rates.
2. The available feed rates in millimeters per revolution.
3. The available feed rates in inches per revolution.
4. The feed lever position column.
5. The available feed rate columns.



Feed Rates

Feed rate gear settings are detailed in **Figure 38**. In the example below we will be selecting gears for a feed rate of 0.002" per revolution:

1. Find 0.002" on the chart in **Figure 38**.
2. Locate the number in gear position A, which is above 0.002". The number in this case is 24, representing a gear with 24 teeth.
3. Look at the column for the feed lever position and find the roman numeral next to the 0.002". In this case III.
4. Change the gears at the B, C, & D locations as necessary (see **Figures 38 & 42**).

To make a cut using a feed rate of 0.002" per revolution, install the 24 tooth gear into position A, (see **Figure 38**) and move the feed lever into position III as in **Figure 39**. For making any other gear changes, see the section titled **Changing Gears** on **Page 39**.

Note— The corresponding feed rate in millimeters would be 0.05 millimeters per revolution and the gearing is identical.

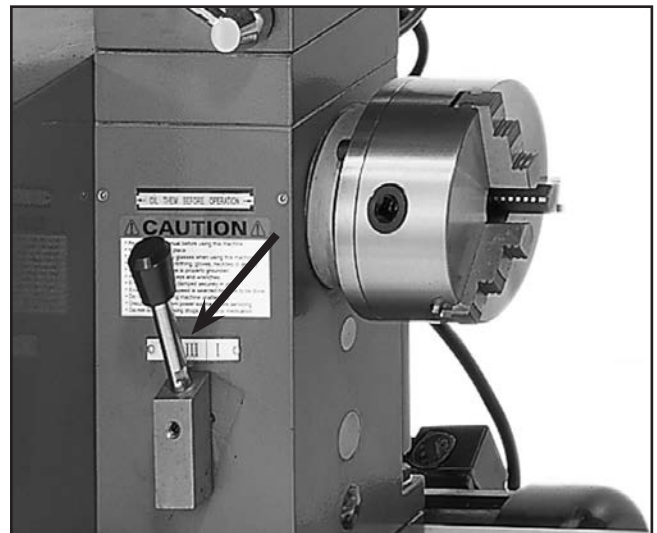

Figure 39. Feed rate selector set to "III".



Half Nut

The half nut lever is located under the left hand side apron (**Figure 40**). This handle may be engaged and disengaged while the machine is running and while making a cut. Move the lever to the down position to engage the half nut. Because the threads of the nut and leadscrew will not always be aligned, engaging the half nut may require waiting until they align, with the machine running. Lift the handle in the direction of the arrow as shown in **Figure 40**. **DO NOT** force the handle, apply light pressure to the handle and when the threads are aligned the handle will engage.

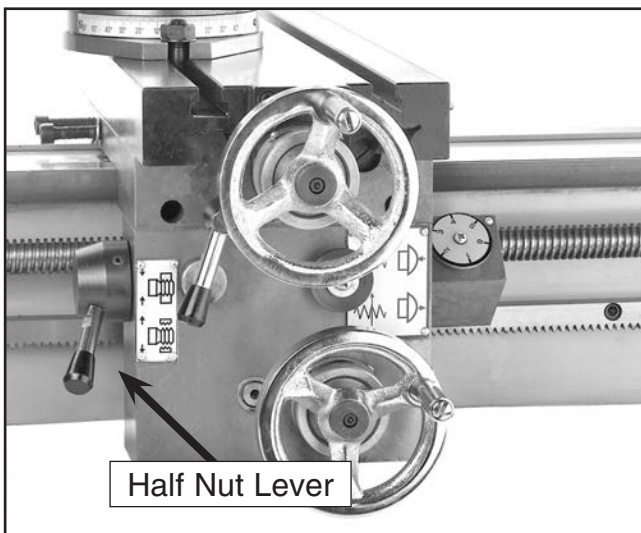

Figure 40. Half nut lever disengaged.



Apron Power Feed

The apron power feed is designed to make work more efficient, provide better surface finishes and aid in cutting threads.

- Once the proper gears have been installed, (see **Changing Gears** on **Page 39**) and the feed rate selected, power to the apron and cross slide is provided by the leadscrew, shown in **Figure 41**.
- In the case of the apron, motion starts by engaging the half nut lever, shown in **Figure 40**.
- In the case of the cross slide, a ring is pulled out, as shown in **Figure 41**.

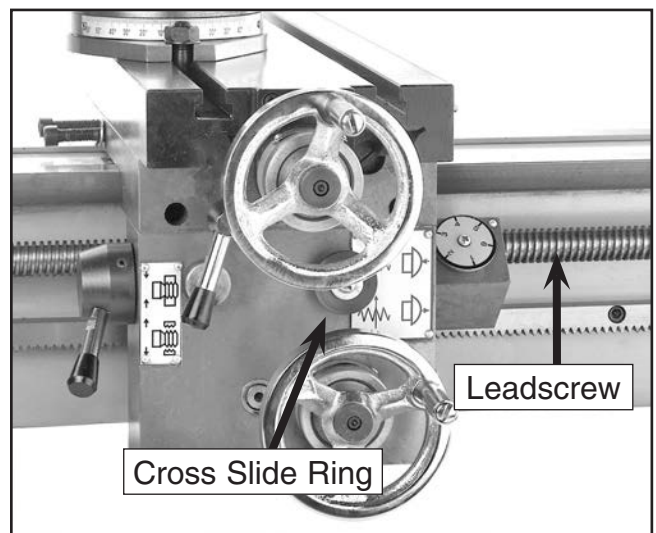

Figure 41. Apron controls.

NOTICE

DO NOT try to engage the half nut & cross slide ring at the same time. While there is a lock-out provided against simultaneous engagement, these components could be damaged if proper procedures are ignored.



Changing Gears

Changing gears on the Model G9729 is straight forward. Refer to the label found on the bottom of the lower belt guard for proper gear selection while following the example below. We will be changing the gears to those that would be used to set the machine for a 0.002" per revolution feed rate. These instructions assume that all of the gears need to be changed. The number of teeth are stamped on each gear.

!WARNING

Always disconnect the power to the machine before making adjustments, set-up changes or cleaning. Failure to do so could result in injury to yourself and others.

NOTICE

Make sure the gears engage properly before operating the machine. Damage to the gears will occur if adjustments are not correct.

To change gears:

1. **Unplug the lathe/mill!**
2. Remove the nuts on the end of the shafts for gears A and D (see **Figure 42**).
3. Loosen the cap screw E, at the bottom of the gear support bracket and allow it to rotate downward.
4. Remove the cap screw in the middle of the combination gear B/C. This will allow removal of the gears and bushing supporting them. A T-nut will remain in the gear support bracket as in **Figure 43**.
5. Remove gears A and D.
6. Replace the gears in positions A and D with 24 and 120 tooth gears, respectively.

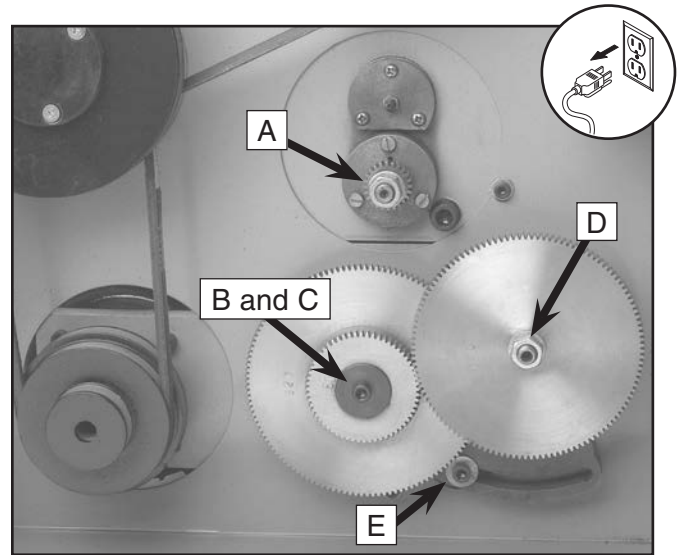

Figure 42. Socket head screw and support bracket with the gears in lower position.

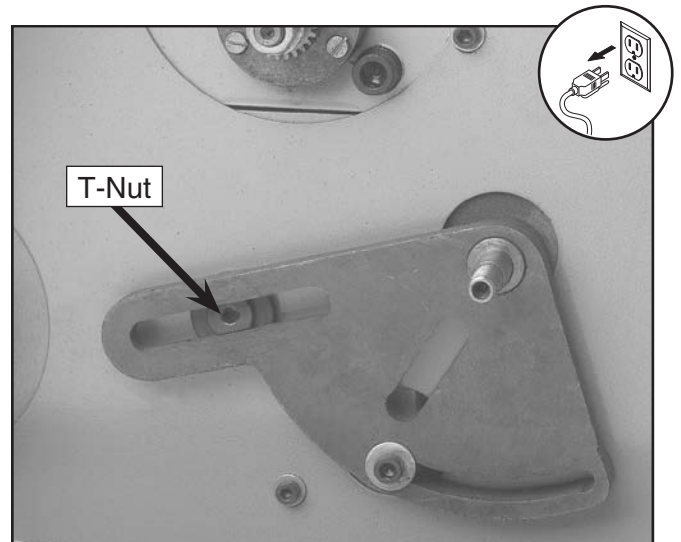

Figure 43. The T-nut remains in the gear support bracket.

7. Insert the bushing into the 60/100 tooth combination gear from the side that has 60 teeth. Align the flats of the bushing to the slot in the gear support arm and loosely fasten the assembly to the T-nut using the cap screw. Slide the combination gear along the slot in the support arm until gear C engages with gear D, and tighten the cap screw (see **Figure 44**).
8. Rotate the support arm until gears B and A are engaged. Tighten the cap screw at the bottom of the gear support arm (**Figure 45**), showing the gears properly aligned and engaged.

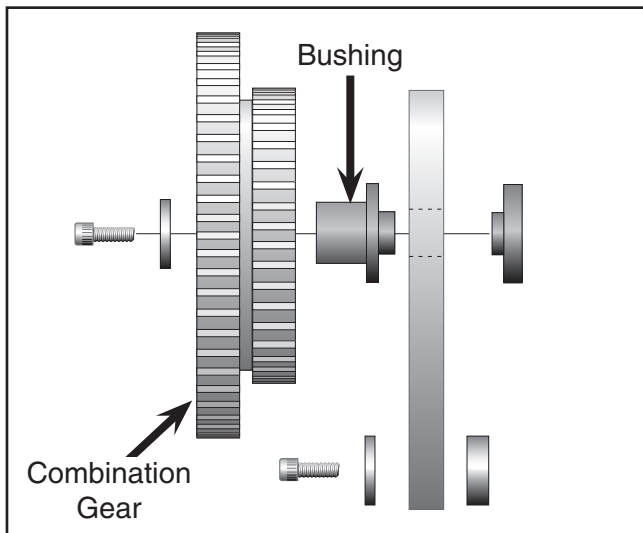

Figure 44. Flats on bushing align with slot.



Figure 45. Gears aligned and engaged.

Inch Threading

The inch threading gear chart is illustrated in **Figure 46**. The layout is listed below to help identify the gears needed for cutting threads with inch pitches. The chart shows pitches in threads per inch.

		2										
		A	D	24	27	30	33	36	39	42	48	60
A	I	4	4.5	5	/	6	/	7	8	10		
	72	II	8	9	10	11	12	13	14	16	20	
	III	16	18	20	22	24	26	28	32	40		
B	120T											
	127T											
	C											
D	I	/	/	/	/	18	/	/	24	30		
	24	II	/	27	30	33	36	39	42	48	60	
	III	/	54	60	66	72	78	84	96	120		

Figure 46. Rates given in threads per inch.

1. The numbers below A represent the number of teeth on the gears used in gear position A— in this case 24 or 72 teeth.
2. The column of numbers to the right of D represent the number of teeth on gears used in gear position D.
3. The gear used in gear position B and C will always be the 120/127 combination gear. The 127 tooth side will be oriented so it is engaged with the gears in the A and D position.
4. Field of possible threads per inch.



The Model G9729 is capable of cutting many standard inch and metric threads. Follow the procedures listed in **Changing Gears** in the previous section and change the gears according to the chart for the thread desired.

Example:

The example shown in **Figures 47–50** depicts the order the gears should be installed for a 120/127, 72, and 30 tooth gear set-up.

Note—This example shows gearing for cutting a 5, 10, or 20 thread per inch (TPI) screw thread. (The Feed Rate Lever set to the I position will allow 5 TPI. When the lever is set to the II position, 10 TPI will be cut and when set to the III position 20 TPI will be cut.)

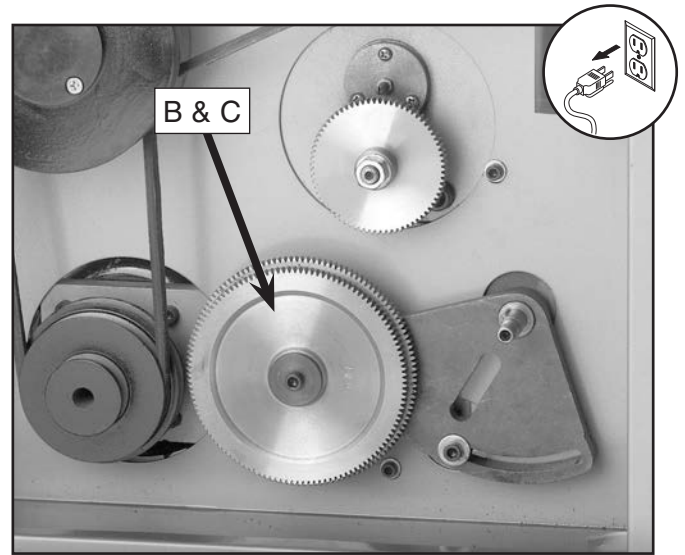

Figure 48. 120/127 tooth combination gear installed at gear position B & C.

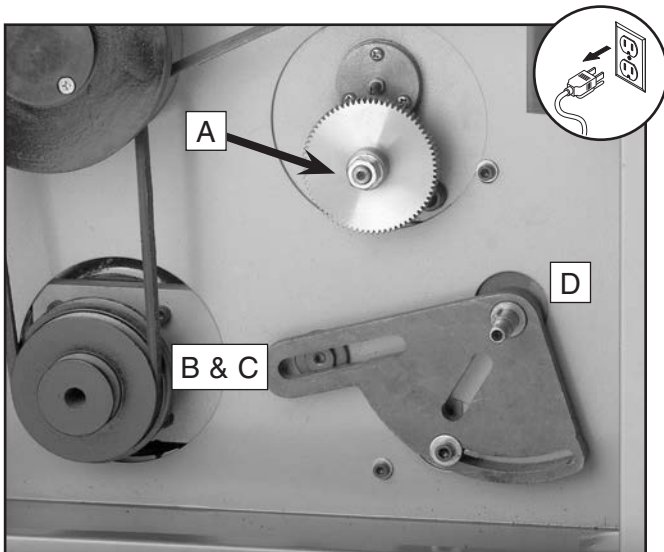

Figure 47. 72 tooth gear installed at gear position A.

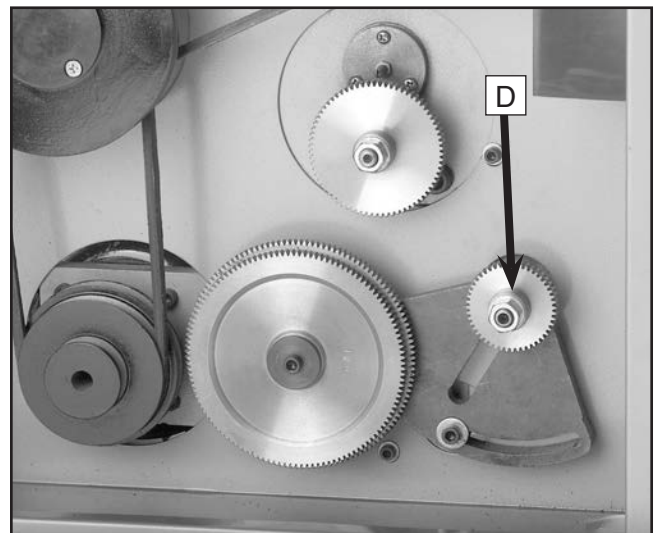

Figure 49. 30 tooth gear installed at gear position D.



Figure 50. Feed rate lever set to I for 5 TPI.

Cutting Threads

1. Set the compound rest to the appropriate angle for the given thread you want to cut. For a Unified National Series thread, this is 29° off of vertical to spindle axis.
2. Set the tool tip perpendicular to the workpiece and center it vertically.
3. Make sure the thread dial is engaged with the lead screw. If not, use a hex key wrench to loosen the screw and rotate the thread dial until the gear engages with the lead screw, then tighten the screw to hold the dial in place.
4. Select the RPM you want to use. A slower RPM will give you more time to react especially if threading over a short distance or threading up to a shoulder.
5. Examine the thread charts (inch or metric), see **Figures 46 & 52** , and then set the feed rate selectors to the appropriate settings.
6. Turn **ON** the spindle to verify settings. Check to see that the lead screw is turning and verify that the apron moves in the correct direction by engaging the half nut lever.
7. Once you are confident the settings are correct, disengage the half nut and turn **OFF** the spindle.

G9729 THREAD DIAL			
TPI	SCALE	TPI	SCALE
4	1 or 4	27	1-6
4.5	1-6	28	1 or 4
5	1 or 4	30	1-6
6	1-6	32	1 or 4
7	1 or 4	33	1-6
8	1 or 4	36	1-6
9	1-6	39	1-6
10	1 or 4	40	1 or 4
11	1 or 4	42	1-6
12	1-6	48	1-6
13	1 or 4	54	1-6
14	1 or 4	60	1-6
16	1 or 4	66	1-6
18	1-6	72	1-6
20	1 or 4	78	1-6
22	1 or 4	84	1-6
24	1-6	96	1-6
26	1 or 4	120	1-6

Figure 51. G9729 Thread dial chart.

8. Examine the thread dial chart in **Figure 51** to determine which numbers (on the thread dial) to engage the half nut.

Note: *There are a total of six marks on the thread dial, ranging 1-6. To maintain accuracy and consistency, engage the half nut on the same mark on each pass. Failure to start on the same number each time may lead to cutting off the thread made in the previous pass.*
9. If cutting metric threads, you will not use the thread dial. Once the half nut is engaged, you must leave it engaged until the threads are complete.



Metric Threading

The metric threading gear chart is illustrated in **Figure 52**. The layout is listed below to help identify gears for cutting threads with metric pitches. The chart below lists threads in millimeters.

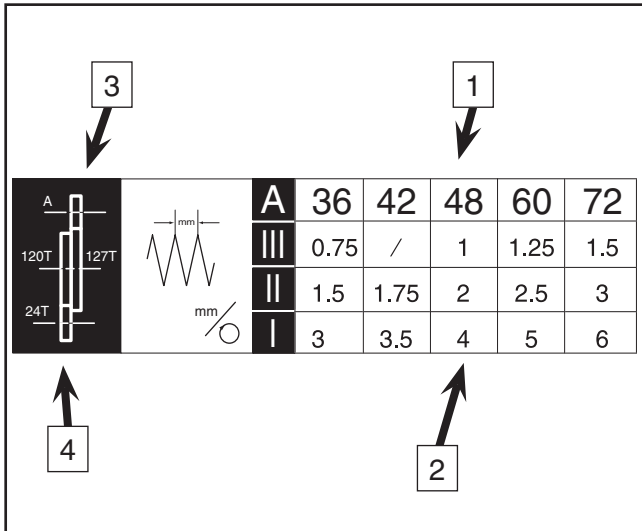

Figure 52. Metric thread pitches & gear chart.

Note—*This chart reflects approximate apron movement per revolution.*

1. The numbers to the right of A represent the number of teeth on gears used in gear position A.
2. Field of possible metric thread pitches.
3. This gear will always be a 120/127 combination gear and will be the intermediate to gears A and D.
4. This gear will always have 24 teeth for metric threading.

Example:

To cut a thread with a pitch of 1.25 mm we would select a 60 tooth gear and place it in gear position A; we would select a 24 tooth gear and place it in gear position D (4 in **Figure 52**); and we would use the 120/127 combination gear. Please note that the 60 tooth gear is engaged with the 127 tooth gear and the 120 gear is engaged with the 24 tooth gear. You can accomplish this by turning the 24 tooth gear so the hub is on the inside as in **Figure 53**.

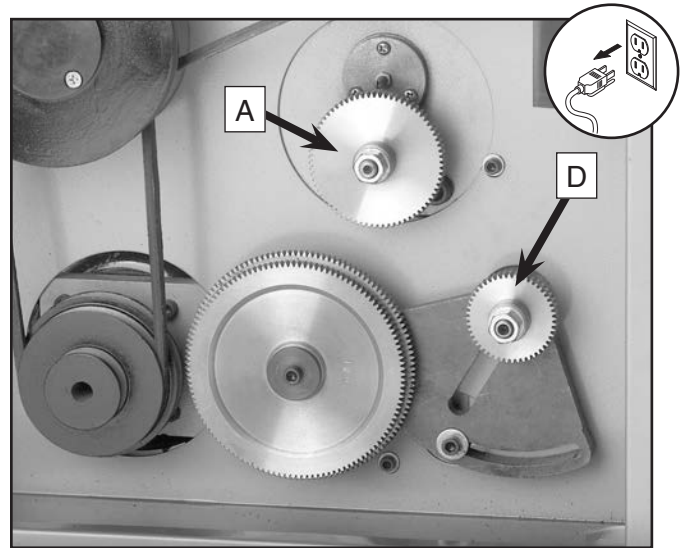

Figure 53. Gear D is turned so hub is on inside.



SECTION 5: MILL OPERATIONS

Mill Speeds

The speed of the drill press spindle is controlled by two belts mounted between three pulleys. The belts and pulleys are accessed by removing the upper belt guard (Figure 54).

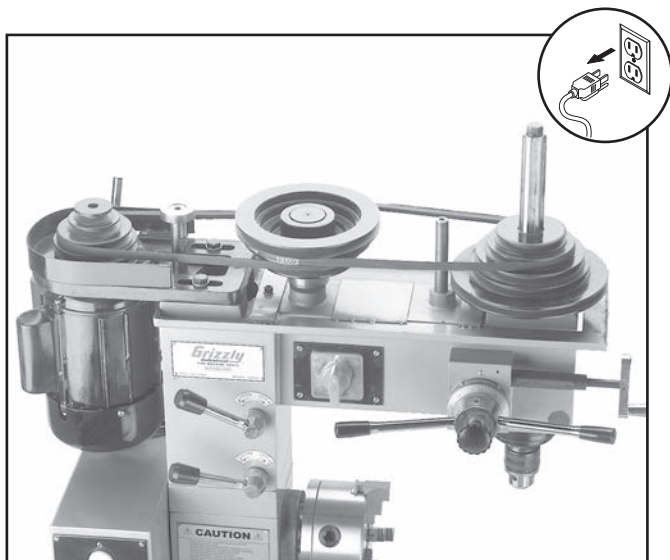

Figure 54. Upper pulleys for speed changes.

THE DRILLING-MILLING UNIT SPEEDS (○/min)							
MOTOR		MIDDLE				SPINDLE	
— A	— B	— A	— C	— A	— D	— B	— A
E —	E —	D —	E —	C —	E —	D —	B —
120	200	310	350	400	450	530	600
— B	— C	— B	— D	— C	— D	— C	— D
C —	D —	A —	C —	B —	B —	A —	A —
660	900	1380	1450	1670	2140	2350	3000

Figure 55. Mill speed chart.

The chart in Figure 55 shows the various combinations of belt positions for achieving a desired speed.

To select a spindle speed of 310 RPM, start by moving the right hand belt to the “D” position. Move the left hand belt to the “A” position.

⚠ WARNING

Always disconnect the power to the machine before making adjustments, set-up changes or cleaning. Failure to do so could result in injury to yourself and others.

To change belt position:

1. Unplug the lathe/mill!
2. Remove the upper belt guard and loosen the belt tension lever as shown Figure 56.
3. Remove the belts from their current location and place them in the desired positions.
4. Apply tension to the belts by pivoting the motor. Secure with the lever.
5. Replace the belt guard.

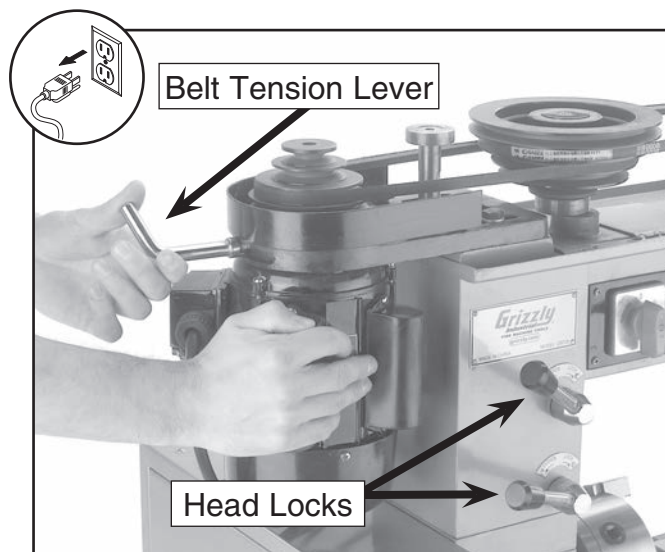

Figure 56. Loosen stud to pivot motor and tension the belt.



Head Rotation

The head of the Model G9729 can be rotated 90° in both directions.

To rotate the head:

1. **Unplug the lathe/mill!**
2. Loosen the head lock handles shown in **Figure 56**.
3. Rotate the head to the desired position.
4. Tighten the head lock handles.

Quill Lock Lever

The height of the spindle can be locked with the quill lock lever. Set the desired height of the spindle, and lock the spindle in place (**Figure 57**).

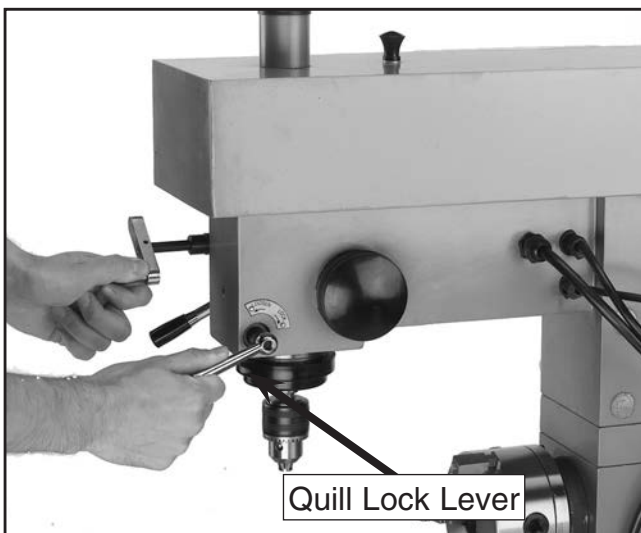

Figure 57. Locking the quill lock lever.



Fine Down Feed

The up and down motion of the mill spindle is controlled just like a drill press. But unlike most drill presses, the Model G9729 is supplied with a fine feed handle, indicated by the arrow in **Figure 58**.

To activate this feature, rotate the quill lever while pressing the black knob in the center of the hub (**Figure 58**). The knob will engage and the spindle will no longer move using the quill lever. Rotating the fine feed handle in a clockwise direction will cause the spindle to go down. To disengage this feature, rotate the fine feed handle and pull on the knob in the center of the hub. Rotating the crank handle will always aid in engaging or disengaging this feature.

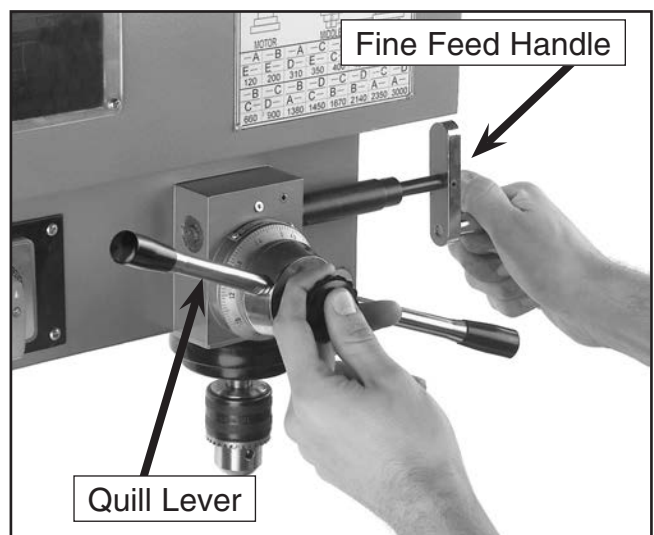

Figure 58. Turning the handle while pressing knob to engage fine feed.



Machine Vise

The Model G9729 comes supplied with a milling vise that also serves as the compound for the lathe. The 4-way tool post must be removed before using the vise.

The milling vise can be aligned to the axis of the lathe or at any angle desired. Care must be given to setting the vise if a precision angle is needed. The following instructions are given to make the jaws parallel to the travel of the cross slide.

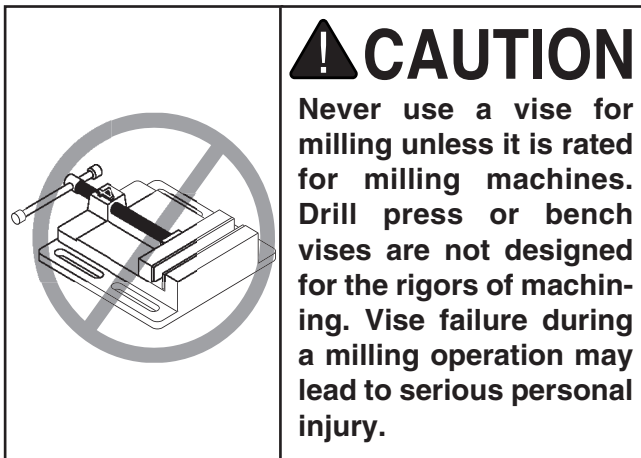

To make the jaws parallel to the cross slide travel:

1. Loosen and remove the lock handle and slide the tool post off of the compound/vise.
2. Loosen the swivel bolts on the compound/vise so it can swivel, but not too freely. Slight resistance will help keep the vise from changing positions unexpectedly, and keep grit from getting between the two surfaces. Pivot the compound/vise so the jaws of the vise are roughly aligned with the cross slide.
3. Place a dial indicator mounted to a magnetic base on the lathe bed using a parallel clamped in the vise jaws (**Figure 59**).
4. Move the cross slide with the handwheel and watch the dial. Note the direction the needle is moving on the dial and by how much.

5. When the vise has moved so the indicator tip is at the other end of the parallel, pivot the vise one half the amount of motion detected in **Step 4**.
6. Move the vise to the starting position and note the difference. Again, pivot the vise one half the difference.
7. Repeat **Steps 4–6** until the dial remains stationary when the vise is moved.
8. Tighten the pivot bolts on the base of the vise and re-indicate to make sure that nothing has moved.

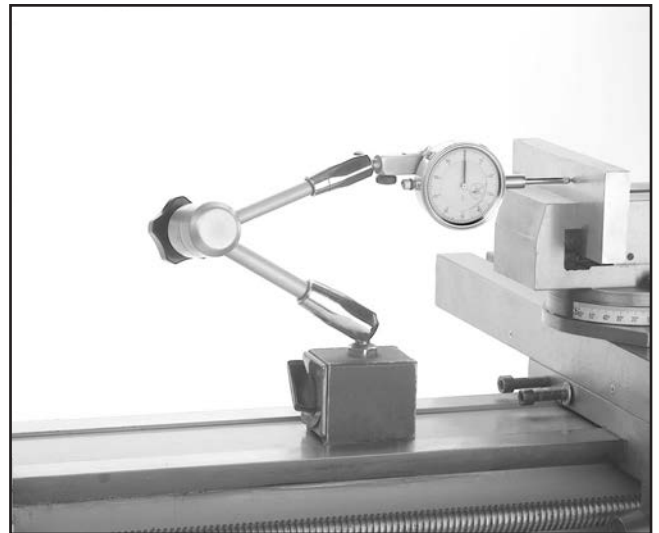

Figure 59. Using a parallel in the vise jaws.



Drill Chuck Removal

The drill chuck and arbor come installed on the drill press/milling spindle from the factory. When the time comes to remove and reinstall it, use these instructions:

To remove the drill chuck from the drill press/milling spindle:

WARNING

Always disconnect the power to the machine before making adjustments, set-up changes or cleaning. Failure to do so could result in injury to yourself and others.

1. **Unplug the lathe/mill!**
2. Return the spindle to the highest position.
3. Remove the small plastic cap on top of the belt guard and unscrew the draw bar 3 turns. *Note—The draw bar screws into the arbor and keeps the arbor from chattering loose when machining or drilling. Three turns on the draw bar is all that you need, any more and the threads on the draw bar and the arbor will be damaged when hitting the end of the draw bar with the hammer. Any less and the arbor does not have enough room to pop loose from the inside taper of the spindle and the outside taper of the arbor.*
4. Secure the quill with the quill lock.
5. Holding onto the outside of the drill chuck with your free hand (never hold onto anything from the bottom, when removing it from the spindle), tap the end of the draw bar with a soft faced mallet. **DO NOT** use a steel hammer! Damage to the draw bar and hammer, such as chipping, may occur.
6. Once the arbor is loose, hold the drill chuck with one hand and unthread the arbor with the other.

Drill Chuck Mounting

1. **Unplug the lathe/mill!**
2. Remove the small plastic cap on top of the belt guard and slide the draw bar out of the spindle through the top.
3. Clean the spindle taper and the arbor taper thoroughly, then wipe with your hand until its clean.
4. Insert the arbor half way into the drill press spindle, then quickly slide it in place to seat the two tapers together.
5. Replace the draw bar and thread it into the arbor. **DO NOT** over tighten! The draw bar only needs to be lightly tightened. Tightening any further will make it difficult to remove the arbor! Again the taper is what holds the two pieces together, the draw bar just keeps them from chattering loose.



SECTION 6: ACCESSORIES

G5641—1-2-3 Blocks

G9815—Parallel Set

Blocks are square to within .0003". Measure 1" x 2" x 3". Parallel set measures 6" long by 1/2", 5/8", 3/4", 7/8", 1", 1 1/8", 1 1/4", 1 1/8", 1 3/8", 1 1/2", and 1 5/8".

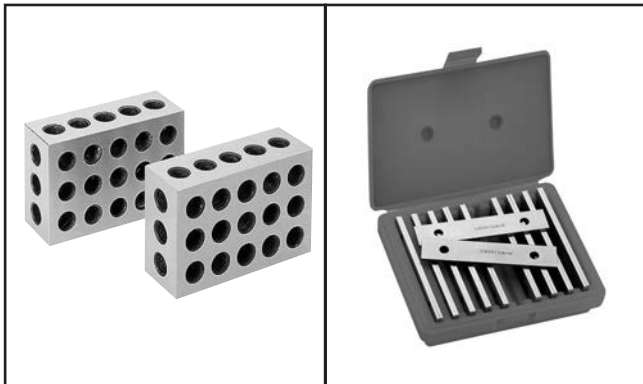

Figure 60. G5641 1-2-3 Blocks and G9815 Parallel Set.

Basic Eye Protection

T20501—Face Shield Crown Protector 4"

T20502—Face Shield Crown Protector 7"

T20503—Face Shield Window

T20451—"Kirova" Clear Safety Glasses

T20452—"Kirova" Anti-Reflective S. Glasses

T20456—DAKURA Safety Glasses, Black/Clear



Figure 61. Our most popular safety glasses.

G9256—6" Dial Caliper

G9257—8" Dial Caliper

G9258—12" Dial Caliper

These traditional dial calipers are accurate to 0.001" and can measure outside surfaces, inside surfaces, and heights/depths. Features stainless steel, shock resistant construction and a dust proof display. An absolute treat for the perfectionist!

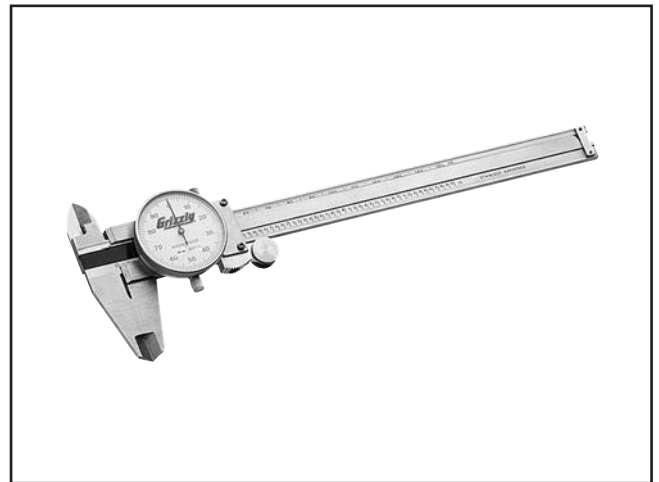

Figure 62. Grizzly® Dial Calipers.

G7895—Citrus Degreaser

This citrus based degreaser is perfect for cleaning cosmolene off of new equipment. It also works for cleaning auto parts, tools, concrete, and porcelain surfaces. Natural, safe for the environment, and contains no CFC's.



Figure 63. G7895 Citrus Degreaser.

G9864—3" 4-Jaw, Plain Back Chuck

G9865—6" 4-Jaw, Plain Back Chuck

Each jaw is adjusted independently. These chucks are used for holding odd shaped pieces or where zero tolerance is required. These chucks have semi-steel bodies and hardened reversible jaws. Requires a mounting plate.



Figure 64. Four-Jaw, Plain Back Independent Chuck.

G5685—MT #1 Live Center

G5686—MT #2 Live Center

G5687—MT #3 Live Center

G5688—MT #4 Live Center

Perfect for just about any turning requirement, these dust, chip, and oil proof live centers feature 60° included angle and preloaded taper bearings. Choose from MT #1 through MT #4.



Figure 65. Live center.

G9610—Test Indicator

.03" Range/.001" Resolution

G9611—Test Indicator

.008" Range/.0001" Resolution

G9612—Test Indicator

.030" Range/.0005" Resolution

These test indicators have an easy to read dial and a pivoting stylus that moves at right angles to the dial face.



Figure 66. Test Indicator.

G3632—Dial Indicator 0-1/2"

G1479—Dial Indicator 0-1"

Precision Dial Indicators are designed for use with magnetic bases. Great for measuring run out on lathes, blades, etc. to 0.001 resolution.



Figure 67. Dial Indicator.

Call 1-800-523-4777 To Order



SECTION 7: MAINTENANCE



Schedule

For optimum performance from your machine, follow this maintenance schedule and refer to any specific instructions given in this section.

Daily Check:

- Loose mounting bolts.
- Damaged tool bits and end mills.
- Worn or damaged wires.
- Any other unsafe condition.
- Lubrication.

Monthly Check:

- V-belt tension, damage, or wear.
- Clean/vacuum dust buildup from inside cabinet and off motor.



Cleaning

Make sure to unplug the lathe/mill before cleaning it. Clean your machine every day or more often as needed. Remove chips as they accumulate. Chips left on the machine soaked with water based coolant will eventually invite oxidation and gummy residue to build up around moving parts. Cleaning will help keep your lathe running smoothly. Always be safe and responsible with the use and disposal of cleaning products.



Unpainted Cast Iron

Protect the unpainted cast iron surfaces on the table by wiping the table clean after every use.

Keep tables rust-free with regular applications of products like, G96® Gun Treatment, SLIPIT®, or Boeshield® T-9 (see **ACCESSORIES** section on **Page 48** for more details).



Lubrication

Your Model G9729 will function best when it is clean and well lubricated. Take the time to wipe down and oil the machine before each use. We recommend using ISO 68 or SAE 20W non-detergent oil unless otherwise specified. Ball fittings will require the use of an oil gun. Press the ball with the tip of the gun and squirt a little oil under pressure. Wipe the ball fitting before and after each use to prevent contamination.

Apron and Cross Slide: Apply lubrication directly to the dovetail ways of the apron and cross slide.

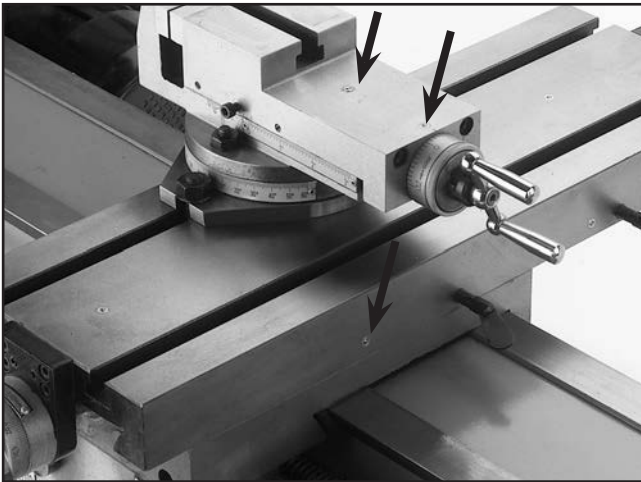

Figure 68. Oil ports indicated by arrows.

Compound: This slide is supplied with ball fittings on its top surface and should be oiled at the same time as the apron (**Figure 68**).

External Gearing: Apply only a minimal amount of oil to the teeth of the end gears after assembly or each day. Note—*Avoid getting oil on the belt or pulleys when lubricating.*

Remove the gear in **Figure 69**, and apply a few drops of oil to the bushing once a day.

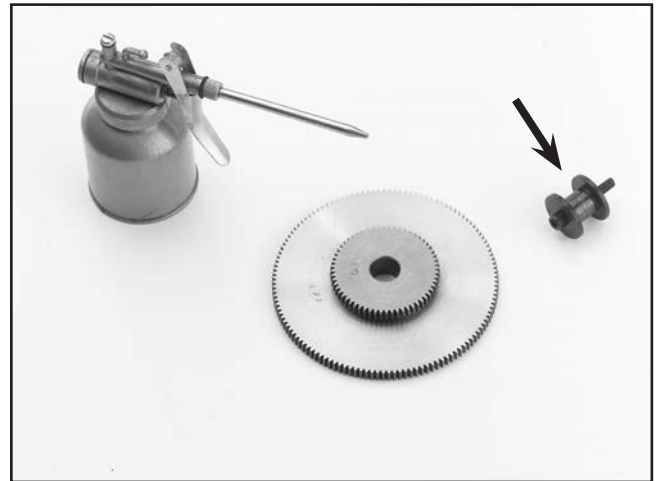

Figure 69. Oil external gears and bushing.

Bearings: Lubrication for the internal gears occurs as the machine runs and oil circulates from the gear box. However, the bearings should be lubricated through the ball fittings indicated by the arrows in **Figure 70**. Apply oil every 3 hours of actual use and just before starting the machine each day.

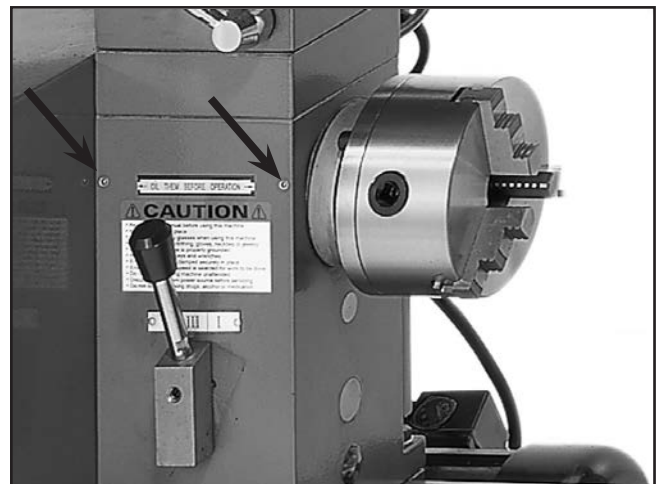

Figure 70. Bearing lubrication points.



Motor: The bearings used in the motor are shielded and lubricated for life, therefore, no lubrication is necessary.

Leadscrew: Be sure to clean and lubricate the leadscrew. There is also a bearing on the tail stock end that will require oil.

Headstock Gearbox: The oil in the headstock should be changed after the first 2 hours of use, then every 6 months, depending on usage. We recommend using a light weight, non-detergent oil. Viscosity can range from 10W to 30W and may include multi-viscosity oil in this same range.

To remove the oil in the gear box, remove the change gear directly under the spindle, remove the cap screw indicated in **Figure 71**, and place a can under the drain hole to collect the waste oil.

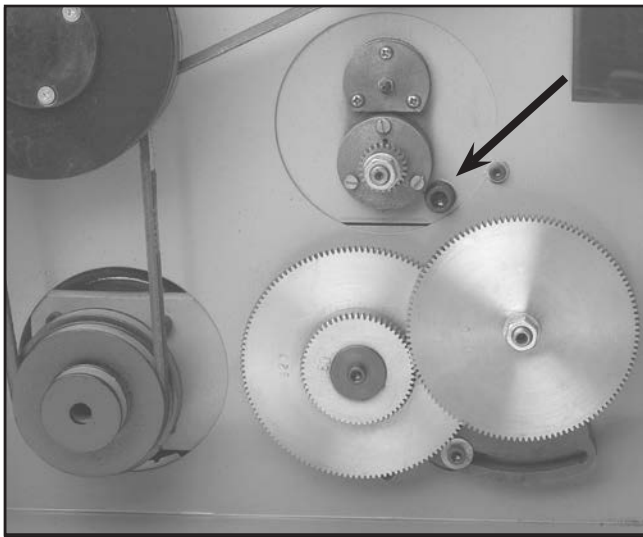

Figure 71. Drain oil cap screw.

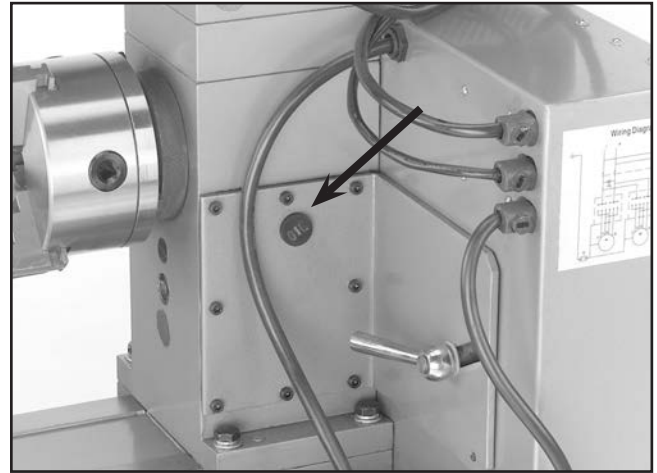

Figure 72. Gear box fill hole.

Tailstock: The tailstock is fitted with 2 oiling ports. The tailstock quill may be oiled directly. Apply oil each week or after every five uses (depending on the frequency of operation). Be sure to clean the slide ways for the tailstock and lift the tailstock and squirt a few drops of oil on the ways. It is a good idea to remove the tailstock, once a month and wipe the bottom thoroughly and replace (**Figure 73**).

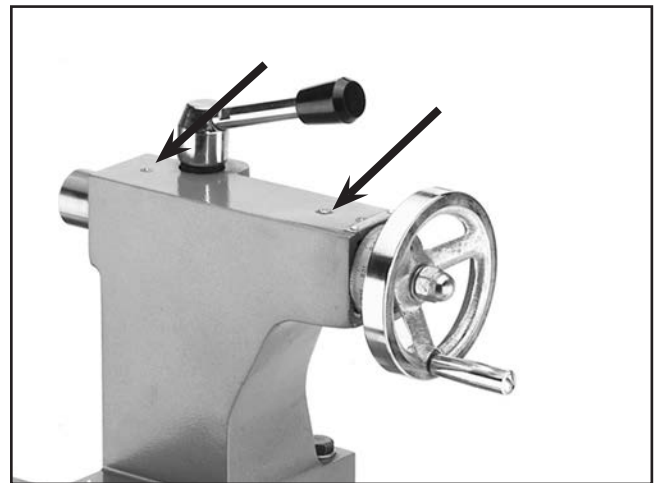
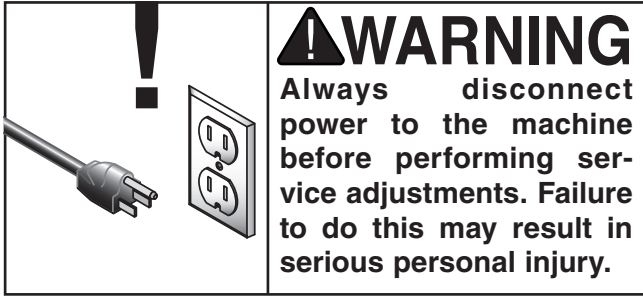

Figure 73. Tailstock oiling points.

SECTION 8: SERVICE



About Service

This section is designed to help the operator with adjustments that were made at the factory and that might also need to be made during the life of the machine.

This section is provided for your convenience—it is not a substitute for the Grizzly Service Department. If any adjustments arise that are not described in this manual, then feel free to call the Grizzly Service Department at (570) 546-9663.

Similarly, if you are unsure of how to perform any procedure in this section, the Grizzly Service Department will be happy to guide you through the procedures or help in any other way.



Gibs

There are three gib adjustments for the Model G9729—the cross-slide gib, the compound slide gib and the apron gib.

Cross-slide Gib: The gib on the cross-slide is adjusted by tightening or loosening the 2 wing bolts located on the right hand side of the slide (see **Figure 74**). These will also serve as table locks.

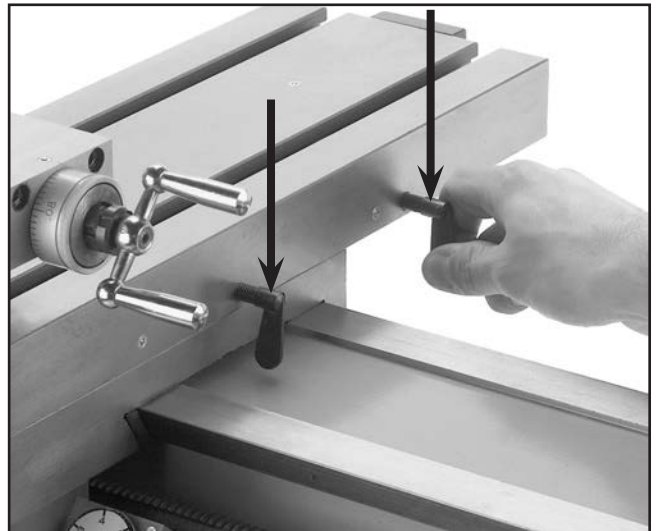

Figure 74. Gib adjustment wing bolts.

Continued on next page →

Compound Gib: The gib on the compound has two set screws to maintain tension on the slide (see **Figure 75**). To adjust these to the proper tension, loosen the cap screw positioned between them and turn the hand crank while adjusting each screw. Tighten until extra effort is required to move the slide then back off the set screw a little. When needed, the slide can be locked in place using the cap screw.

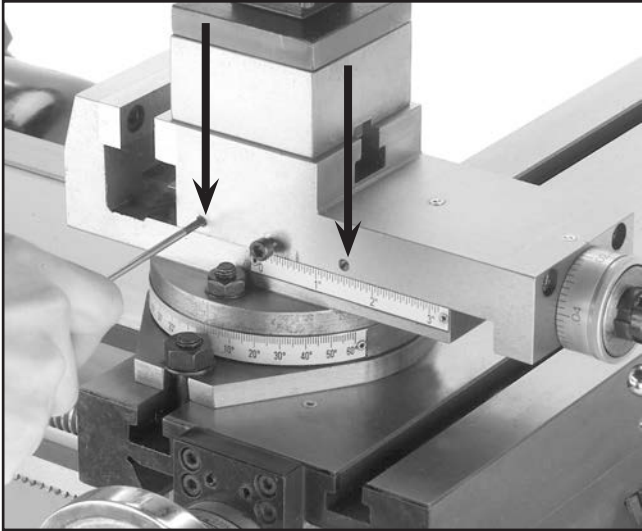

Figure 75. Gib adjustment set screws.

Apron Gib: There are 2 set screws that tension the saddle gib (see **Figure 76**). Before making adjustments to the saddle gib, ensure that the front lock lever is loose by turning it counterclockwise. It is important that the set screws are tightened evenly. A slight drag should be detected while turning the hand crank on the apron.

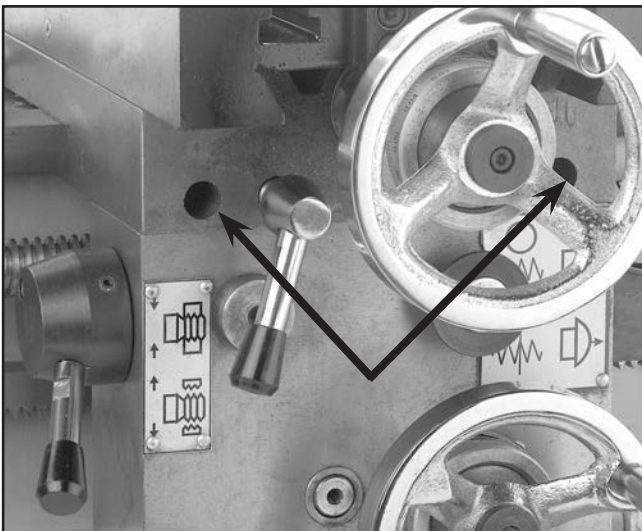

Figure 76. Apron gib set screws.

NOTICE

When adjusting gibs, keep in mind that the goal of gib adjustment is to remove unnecessary movement from the slides movement without causing them to bind. Loose gibs may cause poor finishes on the workpiece and undue wear on the slide, nut and lead screw. Over tightening will make turning the handwheel difficult.



Troubleshooting

Symptom	Possible Cause	Possible Solution
Motor will not start.	<ol style="list-style-type: none"> 1. Low voltage. 2. Open circuit in motor or loose connections. 3. Faulty start capacitor. 	<ol style="list-style-type: none"> 1. Check power line for proper voltage. 2. Inspect all lead connections on motor for loose or open connections. 3. Replace start capacitor.
Motor will not start; fuses or circuit breakers blow.	<ol style="list-style-type: none"> 1. Short circuit in line cord or plug. 	<ol style="list-style-type: none"> 1. Repair or replace cord or plug for damaged insulation and shorted wires.
Motor fails to develop full power (output of motor decreases rapidly with decrease in voltage at motor terminals).	<ol style="list-style-type: none"> 1. Power line overloaded with lights, appliances, and other motors. 2. Undersized wires or circuits too long. 	<ol style="list-style-type: none"> 1. Reduce load on power line. 2. Increase wire sizes or reduce length of the circuit.
Motor overheats.	<ol style="list-style-type: none"> 1. Motor overloaded. 2. Air circulation through the motor restricted. 	<ol style="list-style-type: none"> 1. Reduce load on motor. 2. Clean out motor to provide normal air circulation.
Table hard to move.	<ol style="list-style-type: none"> 1. Table locks are tightened down. 2. Chips have loaded up on bedways. 3. Bedways are dry and in need of lubrication. 4. Longitudinal stops are interfering. 5. Gibs are too tight. 	<ol style="list-style-type: none"> 1. Check to make sure table locks are fully released. 2. Frequently clean away chips that load up during milling operations. 3. Lubricate bedways and handles. 4. Check to make sure that stops are floating and not hitting the center stop. 5. Loosen gib screw(s).
Breaking tools, cutters.	<ol style="list-style-type: none"> 1. RPM and or feed rate is too fast. 2. Cutter getting too hot. 3. Taking too big of a cut. 	<ol style="list-style-type: none"> 1. Use tables to set correct RPM and feed rates. 2. Use cutting fluid or oil for appropriate application. 3. Lessen depth of cut and allow chips to clear.
Workpiece vibrates or chatters during operation.	<ol style="list-style-type: none"> 1. Table locks not tight. 2. Spindle lock not tight. 3. Workpiece not securely clamped to table or into mill vice. 4. RPM and feed rate too high. 	<ol style="list-style-type: none"> 1. Tighten down table locks. 2. Tighten spindle lock. 3. Check that clamping is tight and sufficient for the job. Make sure mill vice is tight to the table. 4. Use appropriate RPM and feed for the job.
Loud repetitious noise coming from machine.	<ol style="list-style-type: none"> 1. Pulley set screws or keys are missing or loose. 2. Motor fan is hitting the cover. 3. V-belts are defective. 	<ol style="list-style-type: none"> 1. Inspect keys and set screws. Replace or tighten if necessary. 2. Adjust fan cover mounting position, tighten fan, or shim fan cover. 3. Replace V-belts.
Bad surface finish.	<ol style="list-style-type: none"> 1. Wrong RPM or feed rate. 2. Dull cutter or poor cutter selection. 3. Wrong rotation of cutter. 	<ol style="list-style-type: none"> 1. Adjust for appropriate RPM and feed rate. 2. Sharpen cutter or select a better cutter for the intended operation. 3. Check for proper cutting rotation for cutting tool.

Electrical Diagram

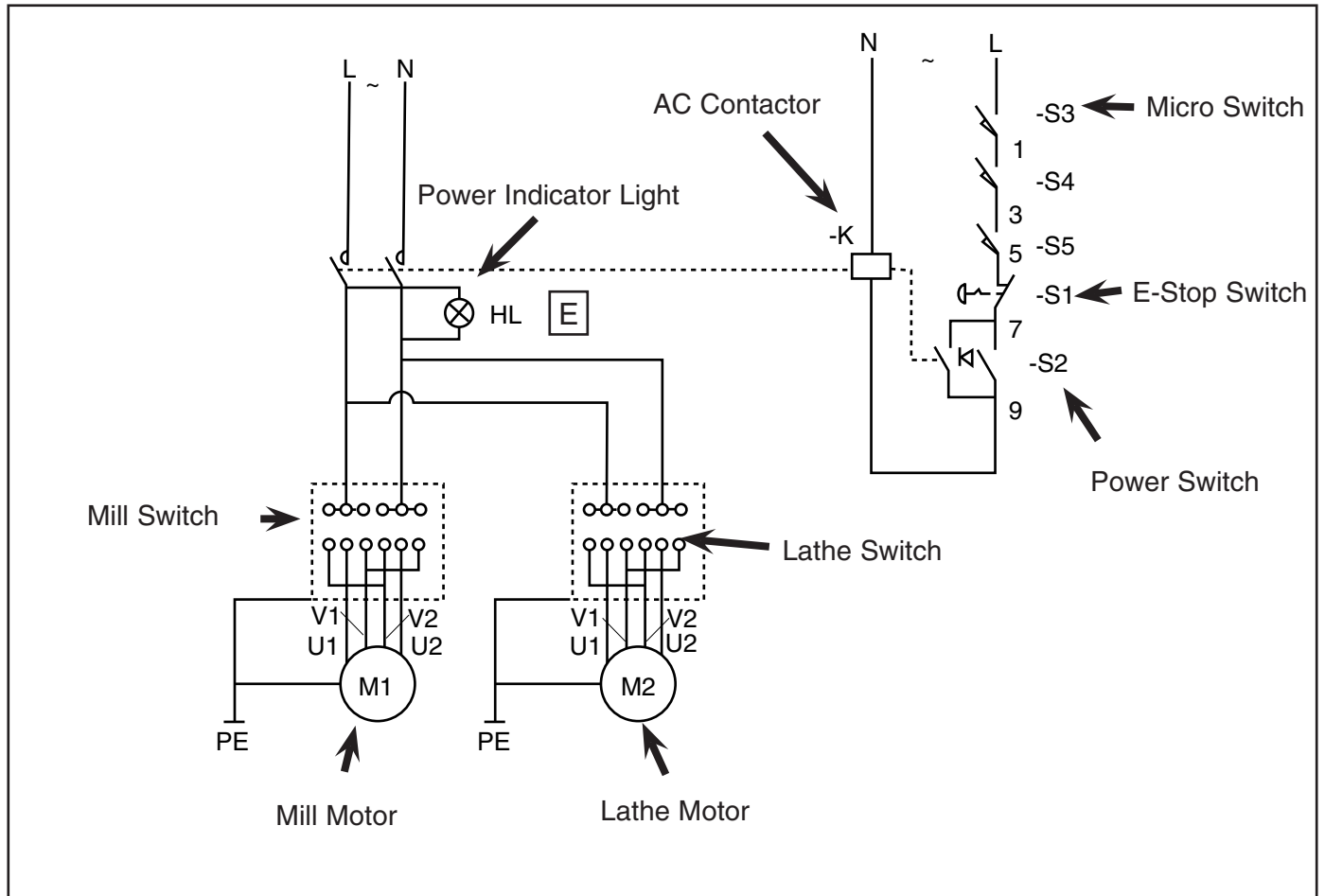
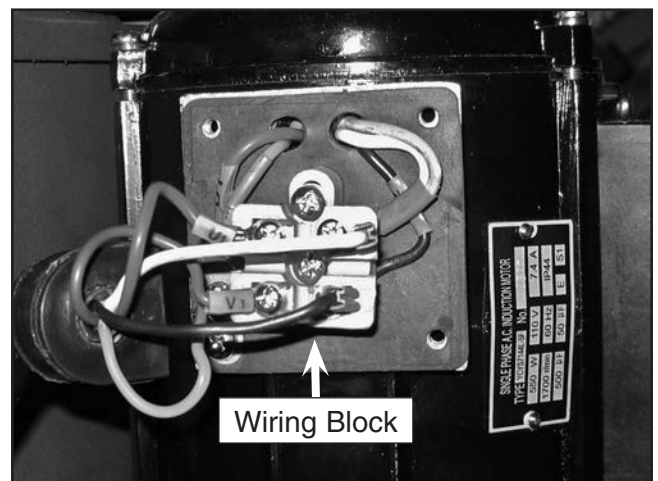
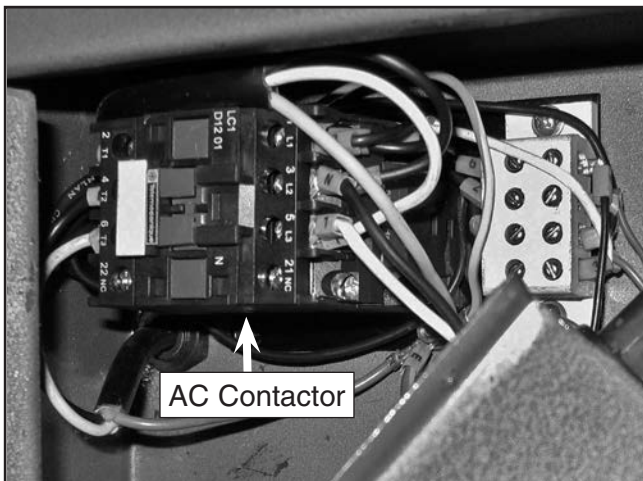
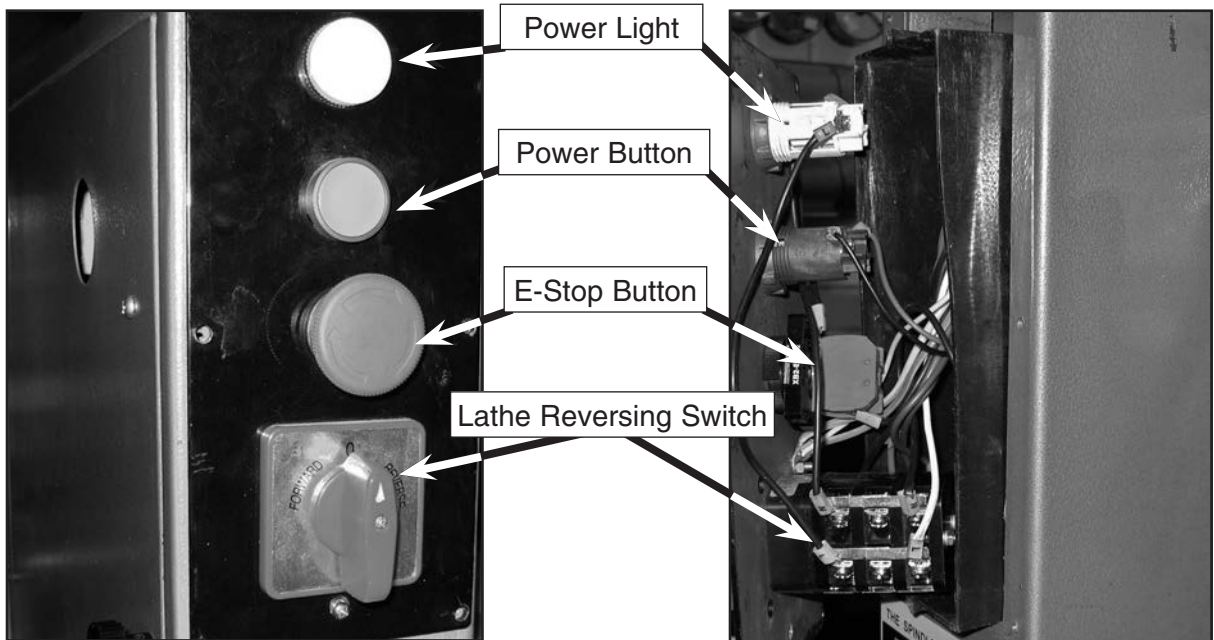
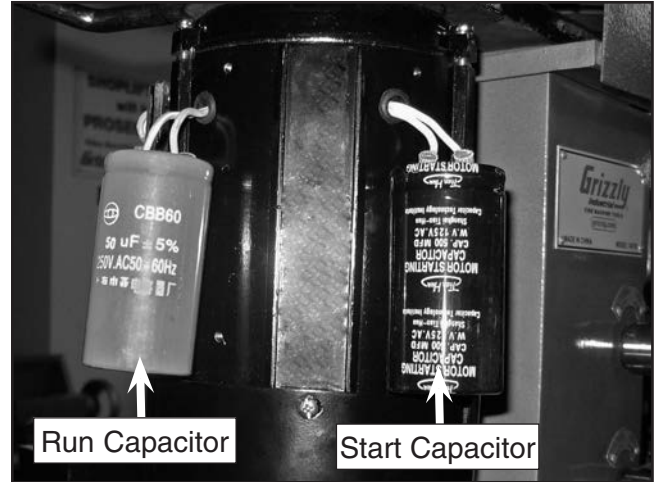
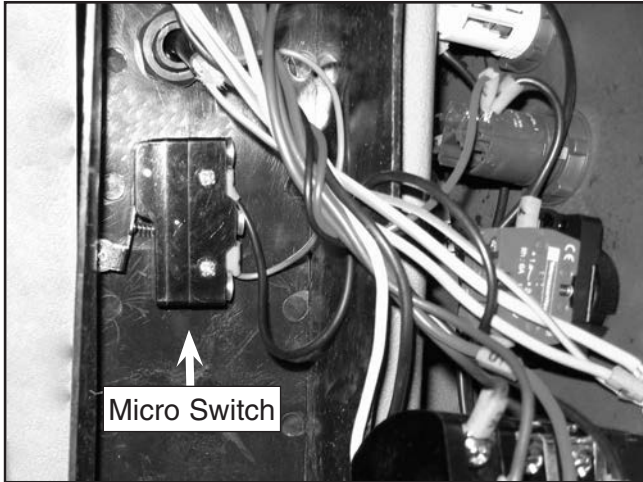

Figure 77. G9729 wiring diagram.

Electrical Components



G9729 Parts Breakdown 0-199 Series

REF	PART #	DESCRIPTION
1	P9729001	3-JAW CHUCK
2	P9729002	DEAD CENTER
6	P9729006	TOOL POST WRENCH
7	P9729007	DOUBLE END WRENCH
8	PAW03M	HEX WRENCH 3MM
8A	PAW04M	HEX WRENCH 4MM
8B	PAW05M	HEX WRENCH 5MM
8C	PAW06M	HEX WRENCH 6MM
8D	PAW08M	HEX WRENCH 8MM
9	P9729009	SCREW DRIVER
10	P9729010	127/60 T GEAR
13	P9729013	27T GEAR
14	P9729014	30T GEAR
15	P9729015	33T GEAR
17	P9729017	42T GEAR
18	P9729018	48T GEAR
19	P9729019	60T GEAR
20	P9729020	72T GEAR
21	P9729021	120T GEAR
22	P9729022	39T GEAR
23	P9729023	TOOL BOX
101	P9729101	BED
102	P9729102	HANDLE KNOB M6-1 X 20
103	P9729103	HANDLE
104	P9729104	HANDLE HUB
105	PSS21M	SET SCREW M8-1.25 X 25
107	P9729107	ADJUSTING BLOCK
108	P9729108	PIN
109	P9729109	TAILSTOCK CARRIAGE
110	P9729110	GIB
110A	P9729110A	DRILL CHUCK ARBOR MT#3
110B	P9729110B	CHUCK KEY
111T	P9729111T	MOTOR
111T-1	P9729111T-1	CAPACITOR 50 MFD 250VAC
111T-2	P9729111T-2	CAPACITOR 500 MFD 125VAC
111T-3	P9729111T-3	JUNCTION BOX
111T-4	P9729111T-4	MOTOR FAN COVER
111T-5	P9729111T-5	MOTOR FAN
111T-6	P9729111T-6	CAPACITOR COVER
11T-7	P9729111T-7	CAPACITOR COVER
112	PK08M	KEY 5 X 5 X 16
113	PB32M	HEX BOLT M10-1.5 X 25
114	PW04M	FLAT WASHER 10MM
115	PVM26	V-BELT M26 3L260
116	PSS20M	SET SCREW M8-1.25 X 8
117	P9729117	PULLEY
118	PSS17M	SET SCREW M8-1.25 X 6
119	PSB02M	CAP SCREW M6-1 X 20

REF	PART #	DESCRIPTION
120	P9729120	MOTOR MOUNT
121	P9729121	T-BUSHING
122	P9729122	BRACKET
123	P9729123	T-NUT
124	P9729124	GEAR 120/127
125	PW03M	FLAT WASHER 6MM
126	PSB29M	CAP SCREW M6-1 X 40
127	P9729127	SPACER
128	PW03M	FLAT WASHER 6MM
129	PW03M	FLAT WASHER 6MM
130	PSB07M	CAP SCREW M6-1 X 30
131	P9729131	GEAR 24T
132	PN02M	HEX NUT M10-1.5
133	P9729133	GEAR 36T
134	P9729134	RACK
135	P9729135	HANDLE M10-1.5 X 80
136	P9729136	ECCENTRIC LEVER
137	PRP42M	ROLL PIN 3 X 20
138	P9729138	TRANSMISSION SHAFT
139	PK69M	KEY 4 X 4 X 12
140	P9729140	SLEEVE
141	P9729141	ROLL PIN 5 X 22
142	P9729142	CLUTCH JAW A
143	P9729143	CLUTCH JAW B
144	P9729144	TRANSMISSION BOX
145	P9729145	LEADSCREW
146	PSS03M	SET SCREW M6-1 X 8
147	P9249002	OILER 6
148	P9729148	TAPER PIN B5X55
149	PSB37M	CAP SCREW M6-1 X 50
150	P9729150	SPANNER NUT M16-1.5
151	P8103	BEARING 8103
152	PK10M	KEY 5 X 5 X 12
153	P9729153	SHAFT CONNECTOR
154	PRP04M	ROLL PIN 4 X 24
155	PRP05M	ROLL PIN 5 X 30
156	P9729156	LEADSCREW SEAT
158	PSB30M	CAP SCREW M6-1 X 45
159	P9729159	DIAL
160	P9729160	DIAL SEAT
161	P9729161	SPRING PIECE
162	PRP39M	ROLL PIN 4 X 20
163	P9729163	LEADSCREW HANDLE
164	PW05M	FLAT WASHER 4MM
165	PS02M	PHLP HD SCR M4-.7 X 12
166	P9729166	COMPRESSION SPRING
167	P9729167	LABEL PLATE
168	P9729168	RIVET

G9729 Lower Head Assembly

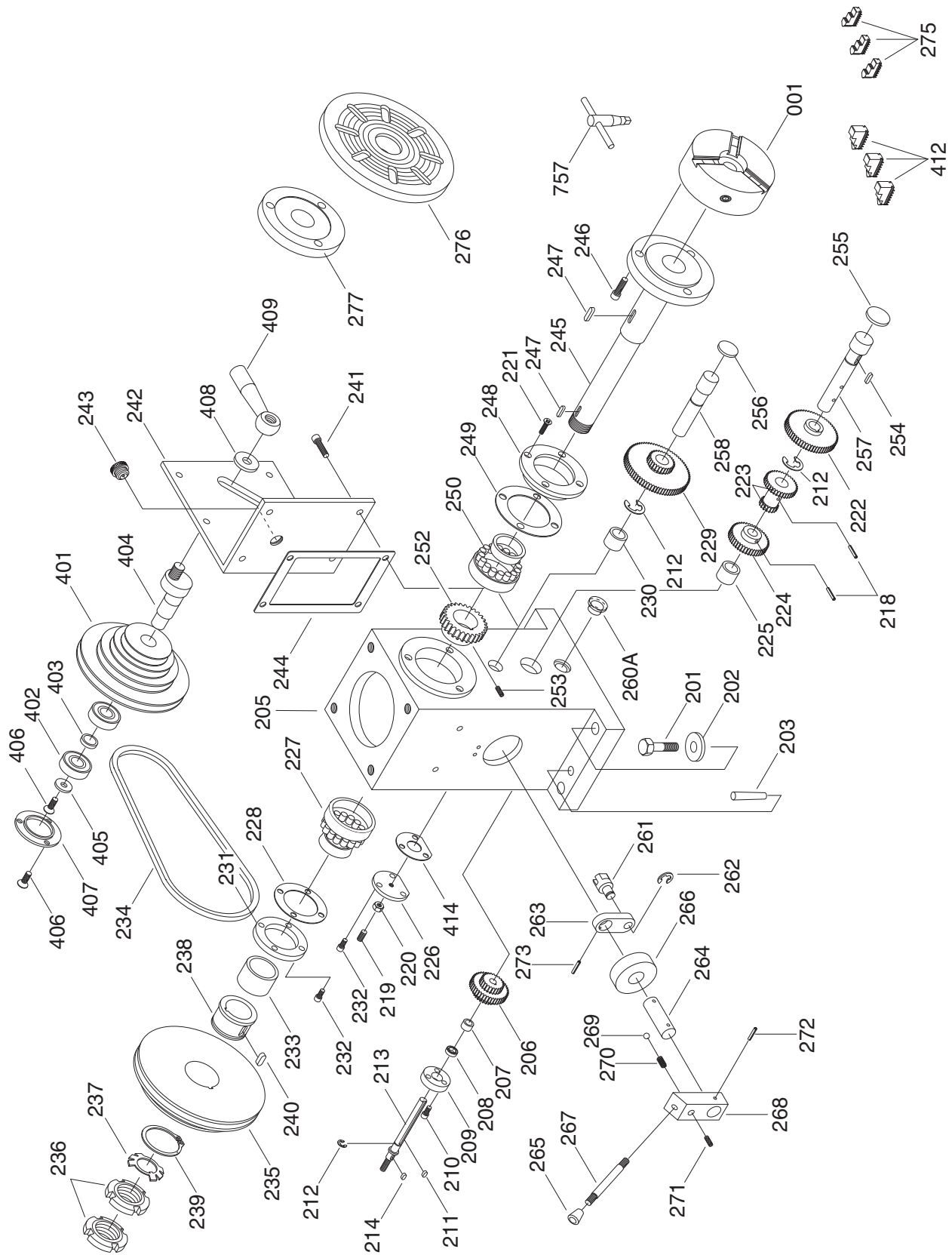

G9729 Parts Breakdown 200 Series

REF	PART #	DESCRIPTION
201	PB31M	HEX BOLT M10-1.5 X 40
202	PW04M	FLAT WASHER 10MM
203	P9729203	TAPER PIN 10 X 40
205	P9729205	HEADSTOCK
206	P9729206	TRIPLEX GEAR
207	P9729207	BRASS BUSHING
208	P9729208	O RING
209	P9729209	O RING SEAT
210	PS08M	PHLP HD SCR M5-.8 X 12
211	PK23M	KEY 5 X 5 X 25
212	PR02M	E-CLIP 14MM
213	P9729213	SHAFT D
214	PK05M	KEY 4 X 4 X 10
218	PRP39M	ROLL PIN 4 X 20
219	PSS57M	SET SCREW M5-.8 X 20
220	PN06M	HEX NUT M5-.8
221	PS08M	PHLP HD SCR M5-.8 X12
222	P9729222	GEAR C
223	P9729223	GEAR C DUPLEX
224	P9729224	GEAR
225	P9729225	BRASS BUSHING
226	P9729226	COVER
227	P9729227	TAPER ROLLER BEARING
228	P9729228	GASKET (LEFT)
229	P9729229	DUPLEX GEAR
230	P9729230	BRASS BUSHING
231	P9729231	COVER (LEFT)
232	PSB97M	CAP SCREW M5-.8 X 6
233	P9729233	SPACER
234	PVM29	V-BELT M-29 3L290
235	P9729235	PULLEY
236	P9729236	SPANNER NUT 40MM
237	P9729237	SPECIAL WASHER 40MM
238	P9729238	PULLEY SPACER
239	PR61M	EXT RETAINING RING 63MM

REF	PART #	DESCRIPTION
240	PK90M	KEY 10 X 10 X 25
241	PSB33M	CAP SCREW M5-.8 X 12
242	P9729242	BRACING PLATE
243	P9729243	OIL PLUG
244	P9729244	GASKET
245	P9729245	SPINDLE
246	PB07M	HEX BOLT M8-1.25 X 25
247	PK91M	KEY 8 X 8 X 22
248	P9729248	FLANGE
249	P9729249	GASKET (RIGHT)
250	P9729250	ROLLER BEARING 45 X 75 X 19
252	P9729252	GEAR A
253	PSS16M	SET SCREW M8-1.25 X 10
254	PK19M	KEY 5 X 5 X 14
255	P9729255	HOLE PLUG
256	P9729256	HOLE PLUG
257	P9729257	SHAFT-C
258	P9729258	SHAFT B
260A	P9729260A	SIGHT GLASS M16-1.5
261	P9729261	FORK
262	PEC12M	E-CLIP 12MM
263	P9729263	FORK ARM
264	P9729264	STRAIGHT PIN 12 X 45MM
265	P9729265	HANDLE KNOB M10-1.5 X 32
266	P9729266	SPACER
267	P9729267	HANDLE
268	P9729268	HANDLE SEAT
269	P4015Z142	STEEL BALL 6.5
270	P9729270	COMPRESSION SPRING
271	PSS17M	SET SCREW M8-1.25 X 6
272	PRP56M	ROLL PIN 4 X 25
273	PRP70M	ROLL PIN 5 X 18
275	P9729275	SET OF INTERNAL JAWS
276	P9729276	9" FACE PLATE
277	P9729277	BACKPLATE

G9729 Parts Breakdown 400 Series

REF	PART #	DESCRIPTION
401	P9729401	IDLER PULLEY
402	P9729402	BALL BEARING 6004
403	P9729403	SPACER
404	P9729404	SHAFT
405	PW02M	FLAT WASHER 5MM
406	PFH07M	FLT HD SCR M5-.8 X 10

REF	PART #	DESCRIPTION
407	P9729407	COVER
408	PW06M	FLAT WASHER 12MM
409	P9729409	HANDLE
412	P9729412	EXTERNAL JAWS
414	P9729414	COVER PLATE

G9729 Belt Guard

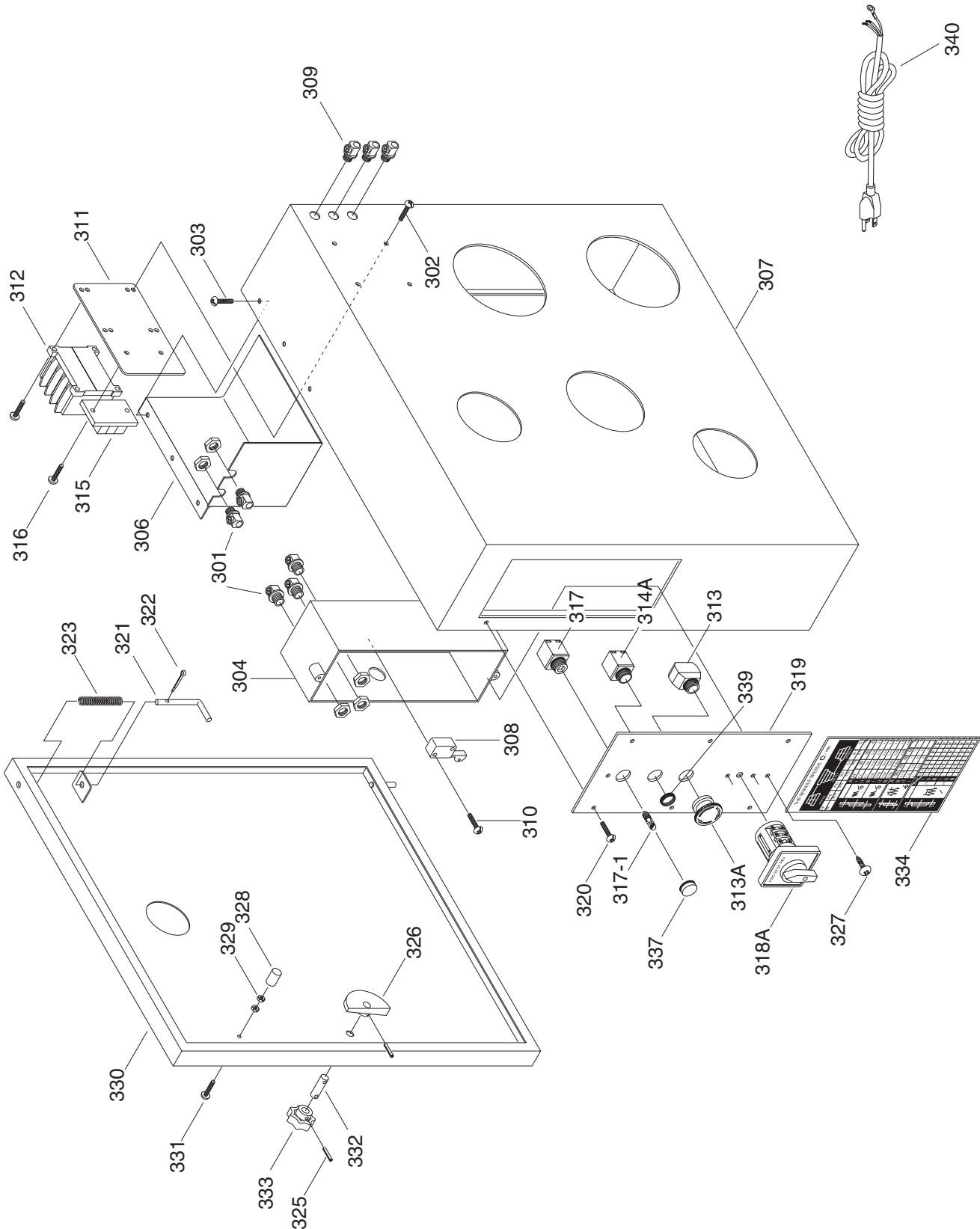

G9729 Parts Breakdown 300 Series

REF	PART #	DESCRIPTION
301	P9729301	STRAIN RELIEF 1/2" SNAP IN
302	PS56M	PHLP HD SCR M4-.7 X 16
303	PS07M	PHLP HD SCR M4-.7 X 8
304	P9729304	ELECTRIC BOX
306	P9729306	ELECTRIC HOUSING
307	P9729307	PULLEY BOX
308	P9729308	MICRO SWITCH
309	P9729309	STRAIN RELIEF 1/2" SNAP IN
310	PS18M	PHLP HD SCR M4-.7 X 25
311	P9729311	ELECTRICAL PANEL
312	P9729312	CONTACTOR LC1 D1201
313	P9729313	KILL SWITCH
313A	P9729313A	E- STOP KNOB
314A	P9729314A	START SWITCH
315	P9729315	WIRE BLOCK
316	PS38M	PHLP HD SCR M4-.7 X 10
317	P9729317	LIGHT INDICATOR
317-1	P9729317-1	INDICATOR BULB
318A	P9729318A	FOR/REV SWITCH ASSY

REF	PART #	DESCRIPTION
319	P9729319	ELECTRICAL PLATE
320	PS38M	PHLP HD SCR M4-.7 X 10
321	P9729321	PIVOT
322	P9729322	STRAIGHT PIN 2 X 12MM
323	P9729323	COMPRESSION SPRING
325	PRP37M	ROLL PIN 3 X 14
326	P9729326	LATCH PIECE
327	PFH41M	FLAT HD SCR M4-.7 X 16
328	P9729328	MICRO SWITCH LEVER
329	PN06M	HEX NUT M5-.8
330	P9729330	DOOR
331	PS82M	PHLP HD SCR M5-.8 X 35
332	P9729332	STUD
333	P9729333	KNOB M8-1.25
334	P9729334	CHART
337	P9729337	LENSE
339	P9729339	START BUTTON
340	P9729340	PLUG NEMA 5-15

G9729 Parts Breakdown 500 & 600 Series

REF	PART #	DESCRIPTION
501	PVM33	V-BELT M-33 3L330
502	PSB47M	CAP SCREW M10-1.5 X 40
503	P9729503	MILL-DRILL HEAD
504	P9729504	SUPPORT COLUMN
505	P9729505	BRAKE PAD (PAIR)
506	P9729506	BRAKE SPACER
507	P9729507	STUD M10-1.5 X 80
508	P9729508	HANDLE SEAT
509	P9729509	HANDLE
510	P9729510	HANDLE KNOB M10-1.5 X 80
511A	P9729511A	MILL MOTOR SWITCH
512	P9729512	SWITCH PLATE
514	P9729514	FRAME COVER
515	P9729515	ECCENTRIC FLANGE
516	PSB02M	CAP SCREW M6-1 X 20
517	PSS14M	SET SCREW M8-1.25 X 12
518	P9729518	MOTOR PULLEY
519	PS17M	PHLP HD SCR M4-.7 X 6
520	P9729520	SEE-THROUGH WINDOW
521	P9729521	MILL-DRILL COVER UPPER
522	P9729522	PULLEY SEAT FLANGE
523	PSB29M	CAP SCREW M6-1 X 40
524	P9729524	TAPER PIN 5 X 45
525	P6008	BEARING 6008
526	PR68M	EXT RETAINING RING 40MM
527	PVM35	V-BELT M-35 3L350
528	P9729528	MILL-DRILL PULLEY
529	P9729529	MOTOR SPEED KNOB
530	P9729530	CAP
532	P9729532	MILL DRILL COVER POST
533	P9729533	POST INSERT
534	P9729534	MICRO SWITCH
535	P9729535	BRAKE SPACER
536	P9729536	STUD M10-1.5 X 60
537	P9729537	HANDLE M10-1.5 X 80

REF	PART #	DESCRIPTION
541	P9729541	HOLE PLUG
543	P9729543	MILL DRILL COVER(LOWER)
544	PW03M	FLAT WASHER 6MM
545	PS14M	PHLP HD SCR M6-1 X 12
546	P9729546	MOTOR MOUNT
547	PB01M	HEX BOLT M10-1.5 X 30
548	P9729548	MILL DRILL COVER POST
550	P9729111T	MOTOR 3/4HP
551	PK08M	KEY 5 X 5 X 16
552	P9729552	TENSION HANDLE
553	PS26M	PHLP HD SCR M6-1 X 20
554	P9729554	ECCENTRIC SHAFT
555	P9729555	IDLE PULLEY
556	P6004	BALL BEARING 6004
557	P9729557	SPACER
558	PR62M	EXT RETAINING RING 42MM
559	P9729559	BEARING COVER
560	PFH07M	FLT HD SCR M5-.8 X 10
561	P9729561	QUILL
562	P9729562	GASKET
563	P9729563	BALL BEARING 35 X 62 X 17
564	P9729564	SPLINE SPINDLE
565	P9729565	COVER
566	PSS26M	SET SCREW M5-.8 X 6
567	P9729567	BALL BEARING 30 X 55 X 16
568	P9729568	SPANNER NUT M30-2
569	PW23M	FLAT WASHER 30MM
570	P9729570	COLLAR
571	P9729571	LABEL PLATE
572	P9729572	SCALE
573	P9729573	RIVET
574	PSB14M	CAP SCREW M8-1.25 X 20
577	P9729577	DRILL CHUCK 1/2" JT#33
578	P9729578	DRAW BAR
579	PW03M	FLAT WASHER 6MM

REF	PART #	DESCRIPTION
601	P9729601	QUILL FEEDING BOX
602	P9729602	GEAR SHAFT
603	PK81M	KEY 6 X 6 X 12
604	P9729604	COVER
605	P9729605	WORM GEAR
606	P9729606	CLUTCH JAW
607	PRP27M	ROLL PIN 5 X 28MM
608	P9729608	STUD
609	P9729609	DIAL
610	P9729610	SPRING PIECE
611	P9729611	HANDLE HUB
612	P9729612	HANDLE
613	P9729613	HANDLE KNOB M8-1.25 X 40
614	PSS58M	SET SCREW M6-1 X 18

REF	PART #	DESCRIPTION
615	P9729615	KNURLED KNOB M10-1.5
616	P9729616	WORM
617	P9729617	DIAL SEAT
618	P9729618	FLAT COIL SPRING
619	PSS24M	SET SCREW M5-.8 X 25
620	P9729620	WORM SHAFT
621	PRP39M	ROLL PIN 4 X 20
622	P9729622	CRANK
623	PRP19M	ROLL PIN 4 X 14
624	P9729624	HANDLE M8-1.25 X 40
625	P9729625	TAPER PIN 5 X 35
626	P9249002	OILER 6
627	P9729627	SPRING HOUSING COVER
628	P9729628	SPRING HOUSING

G9729 Crossslide Assembly

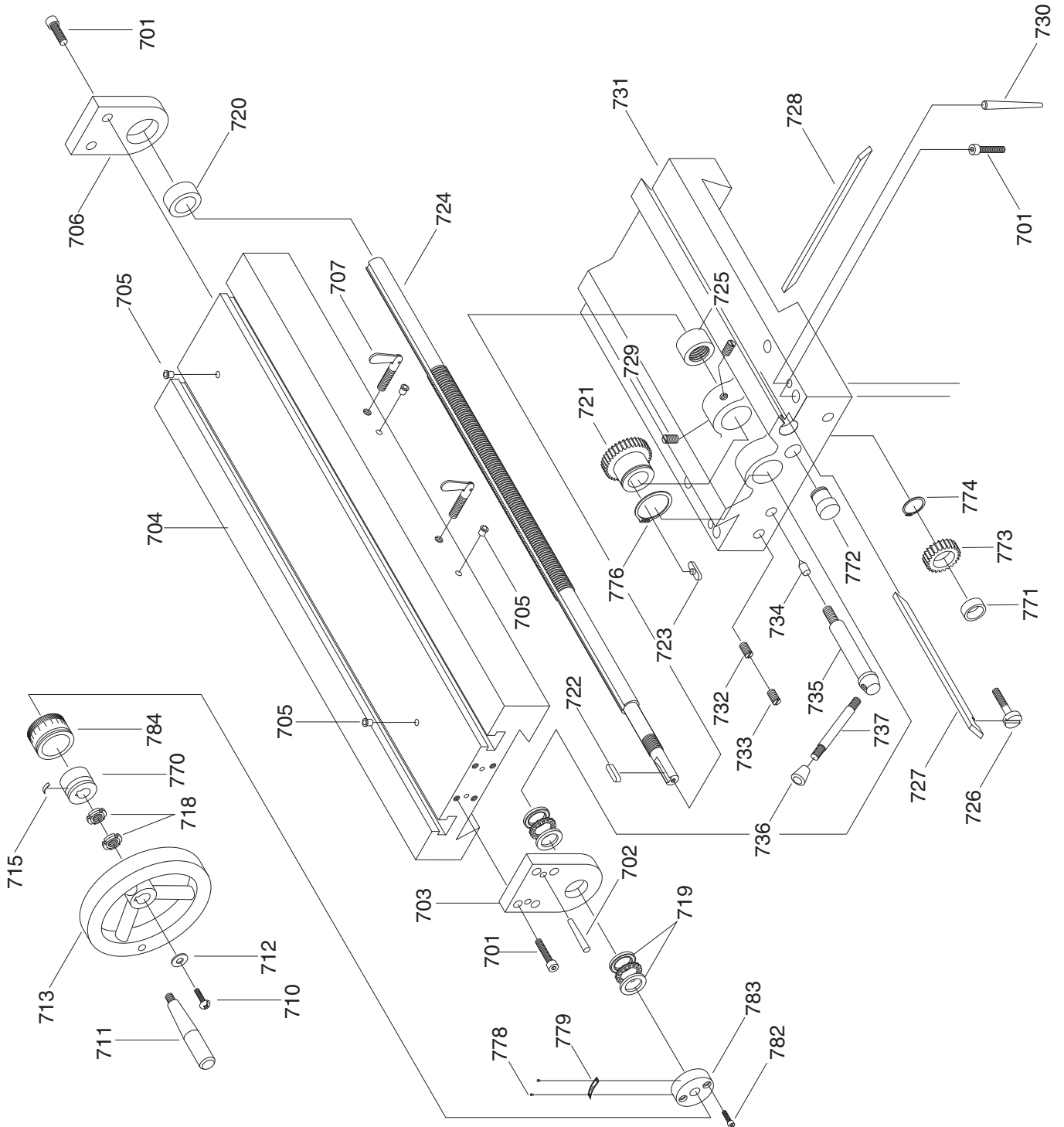

G9729 Parts Breakdown 700 Series

REF	PART #	DESCRIPTION
701	PSB15M	CAP SCREW M5-.8 X 20
702	P9729702	TAPERED PIN 5 X 25
703	P9729703	END PLATE B
704	P9729704	TABLE
705	P9249002	OILER 6
706	P9729706	END PLATE
707	P9729707	LOCKING SCREW
710	PS19M	PHLP HD SCR M5-.8 X 6
711	P9729711	HANDLE
712	PW02M	FLAT WASHER 5MM
713	P9729713	HANDWHEEL 12 X 100
715	P9729715	SPRING PIECE
718	P9729718	SPANNER NUT M14 X 1.5
719	P51102	THRUST BEARING 51102
720	P9729720	SPACER A
721	P9729721	GEAR
722	PK102M	KEY 4 X 4 X 18
723	P9729723	T-KEY
724	P9729724	CROSSFEED SCREW
725	P9729725	CROSS FEED NUT
726	P9729726	ADJUST SCREW
727	P9729727	TABLE GIB
728	P9729728	CARRIAGE GIB
729	PSS03M	SET SCREW M6-1 X 8
730	P9729730	TAPER PIN 5X25
731	P9729731	CARRIAGE
732	PSS06M	SET SCREW M8-1.25 X 16
733	PSS14M	SET SCREW M8-1.25 X 12
734	P9729734	PIN
735	P9729735	LOCK STUD
736	P9729736	LOCK HANDLE
737	P9729737	HANDLE M6-1 X 32
738	PSS20M	SET SCREW M8-1.25 X 8
739	P9729739	COMPRESSION SPRING
740	P4015Z142	STEEL BALL 6.5
741	P9729741	HANDLE SEAT
742	P9729742	HANDLE M6-1 X 50
743	P9729743	ECCENTRIC WHEEL

REF	PART #	DESCRIPTION
744	PRP49M	ROLL PIN 5 X 25
745	P9729745	PIN
746	P9729746	PIVOT ARM
747	P9729747	STOP PIN
748	P9729748	PIVOT
749	P9729749	SPACER E
750	P9729750	SPACER B
751	P9729751	GEAR
752	PRP20M	ROLL PIN 4 X 22
753	P9729753	SPACER C
754	P9729754	SHAFT PINION
757	P9729757	LATHE CHUCK KEY
758	PK05M	KEY 4 X 4 X 10
759	P9729759	GEAR
760	P9729760	APRON
761	PSS124M	SET SCREW M8-1.25 X 16 DOG-PT
763	P9729763	BEVEL GEAR
764	PS03M	PHLP HD SCR M6-1 X 8
765	PW03M	FLAT WASHER 6MM
766	P9729766	PULL-PUSH KNOB
767	PW06M	FLAT WASHER 12MM
768	P9729768	GEAR
769	P9729769	SHAFT
770	P9729770	DIAL SEAT B
771	P9729771	BRASS BUSHING
772	P9729772	SHAFT
773	P9729773	GEAR
774	PR03M	EXT RETAINING RING 12MM
776	PR17M	EXT RETAINING RING 26MM
778	P9729778	RIVET
779	P9729779	SCALE PLATE
780	P9729780	LABEL PLATE
781	P9729781	LABEL PLATE
782	PSB68M	CAP SCREW M6-1 X 8
783	P9729783	COVER PLATE
784	P9729784	LARGE DIAL
785	P9729785	SHAFT

G9729 Apron Assembly

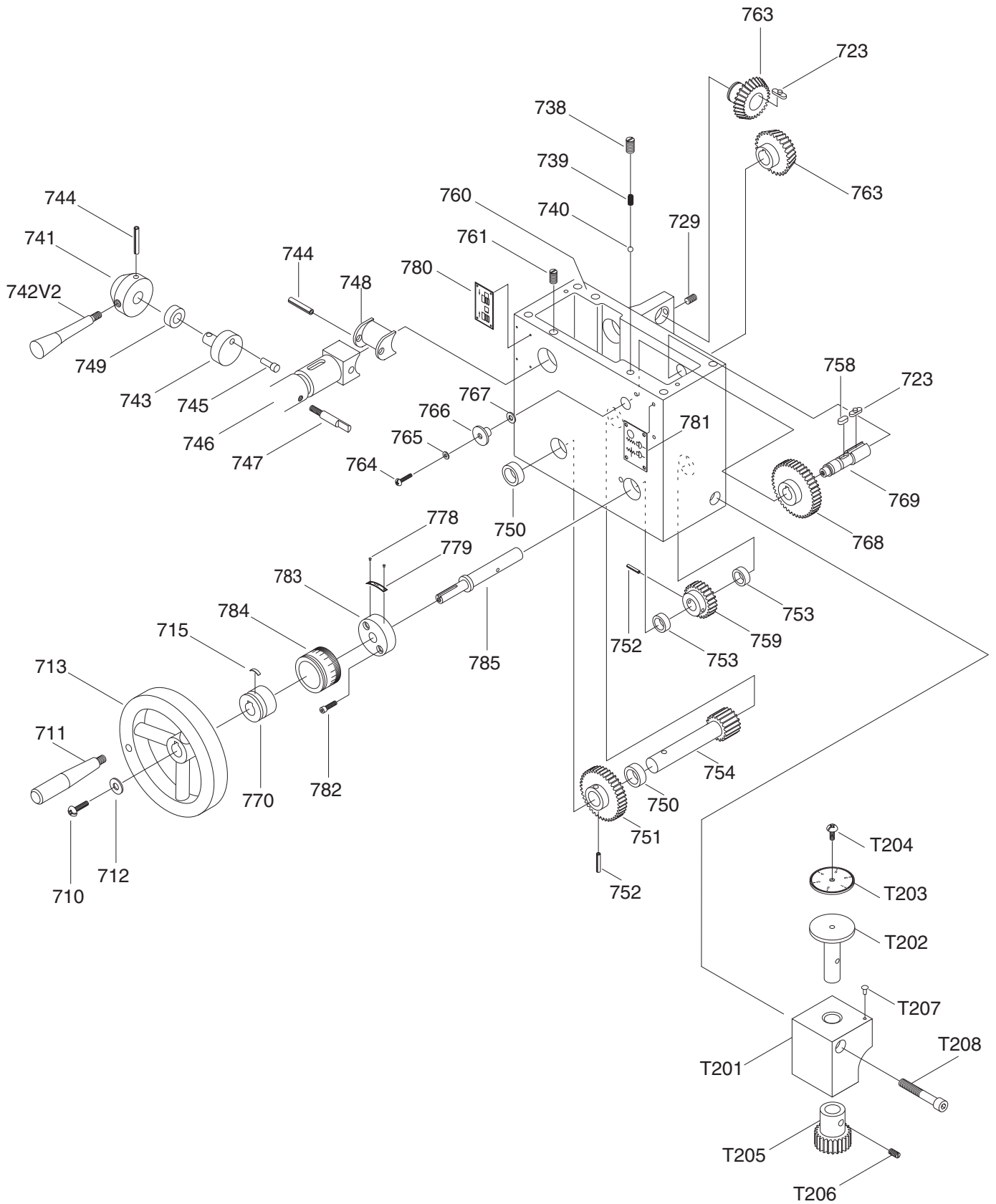

G9729 Parts Breakdown T Series

REF	PART #	DESCRIPTION
T201	P9729T201	THREAD DIAL SEAT
T202	P9729T202	SHAFT
T203	P9729T203	INDICATOR PLATE
T204	P9729T204	PHLP HD SCREW M4-.7 X 12
T205	P9729T205	GEAR
T206	P9729T206	SET SCREW M5-.8 X 8
T207	P9729T207	RIVET
T208	PCAP30M	CAP SCREW M6-1 X 45
T501	P9729T501	STEADY REST CENTER FRAME
T501-1	P9729T501-1	STEADY REST ASSEMBLY
T502	P9729T502	STDY REST CNTR FRAME HEAD
T503	P9729T503	KNOB M8-1.25
T504	PW01M	FLAT WASHER 8MM
T505	P9729T505	LOCKING BOLT
T506	P9729T506	COTTER PIN 6 X 20
T507	PW03M	FLAT WASHER 6MM
T508	P9729T508	LOCKING PIN
T509	P9729T509	BRASS HEAD
T510	P9729T510	FINGER SLEEVE
T511	P9729T511	ADJUSTING BOLT
T512	P9729333	KNOB M8-1.25 X 32
T513	PRP02M	ROLL PIN 3 X 16
T514	PSS64M	SET SCREW M6-1 X 15
T515	PN01M	HEX NUT M6-1
T516	PSB44M	CAP SCREW M10-1.5 X 28
T517	PW04M	FLAT WASHER 10MM
T518	P9729T518	CHOCK
T519	P9729T519	KNURLED SCREW
T606	P9729T606	FOLLOW REST FRAME
T606-1	P9729T606-1	FOLLOW REST ASSEMBLY
T610	PW01M	FLAT WASHER 8MM
T611	PSB13M	CAP SCREW M8-1.25 X 30
T701	PN02M	HEX NUT M10-1.5
T702	PW04M	FLAT WASHER 10MM
T703	P9729T703	T BOLTS M10-1.5
T704	PFH25M	FLAT HD SCR M4-.7 X 12
T705	P9729T705	SQUARE KEY

REF	PART #	DESCRIPTION
T706	P9729T706	BASE
T707	P9729T707	RIVET
T708	P9729T708	SCALE
T709	P9729T709	VICE
T710	P9729T710	VICE JAW
T711	PSB68M	CAP SCREW M6-1 X 8
T712	P9729T712	HANDLE M8-1.25 X 25
T713	PRP02M	ROLL PIN 3 X 16
T714	P9729T714	SPANNER NUT M10-1.5
T715	P9729T715	DIAL SEAT
T716	P9729T716	SPRING PIECE
T717	P9729T717	DIAL
T718	P9729T718	SCREW SET
T719	P9249002	OILER 6
T720	PSB01M	CAP SCREW M6-1 x 16
T721	PK97M	KEY 4 X 4 X 14
T722	P9729T722	LEAD SCREW TR12
T723	P9729T723	LEAD NUT 12-1.75
T724	P9729T724	ANGLE RULE
T725	P9729T725	MOBILE JAW
T727	PSB03M	CAP SCREW M5-.8 X 8
T728	PSS05M	SET SCREW M5-.8 X 10
T729	P9729T729	GIB
T730	P9729T730	T-BOLT M10-1.5 X 100
T731	P9729T731	TOOL BASE
T732	P9729T732	COMPRESSION SPRING
T733	P9729T733	POSITIONER
T734	P9729T734	TOOL POST
T735	P9729T735	TOOL POST SCR M8-1.25 X 25
T736	PW04M	FLAT WASHER 10MM
T737	P9729T737	HANDLE HUB
T738	P9729T738	HANDLE
T739	P9729T739	HANDLE KNOB M10-1.5 X 32
T740	P9729T740	T-BOLT M8-1.25 X 25
T741	PN03M	HEX NUT M8-1.25
T742	PW01M	FLAT WASHER 8MM

G9729 Rests Assemblies

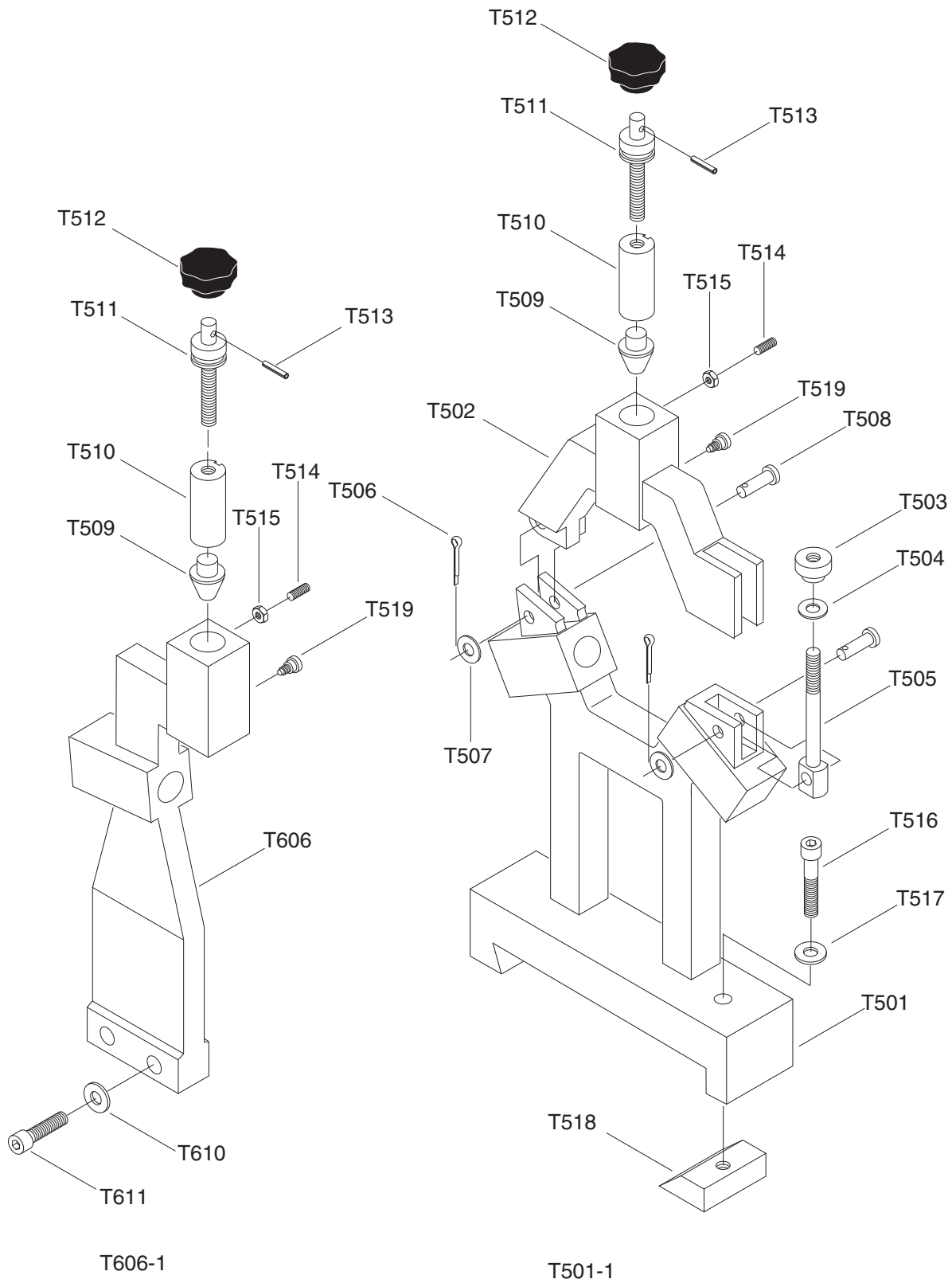

G9729 Compound Assembly

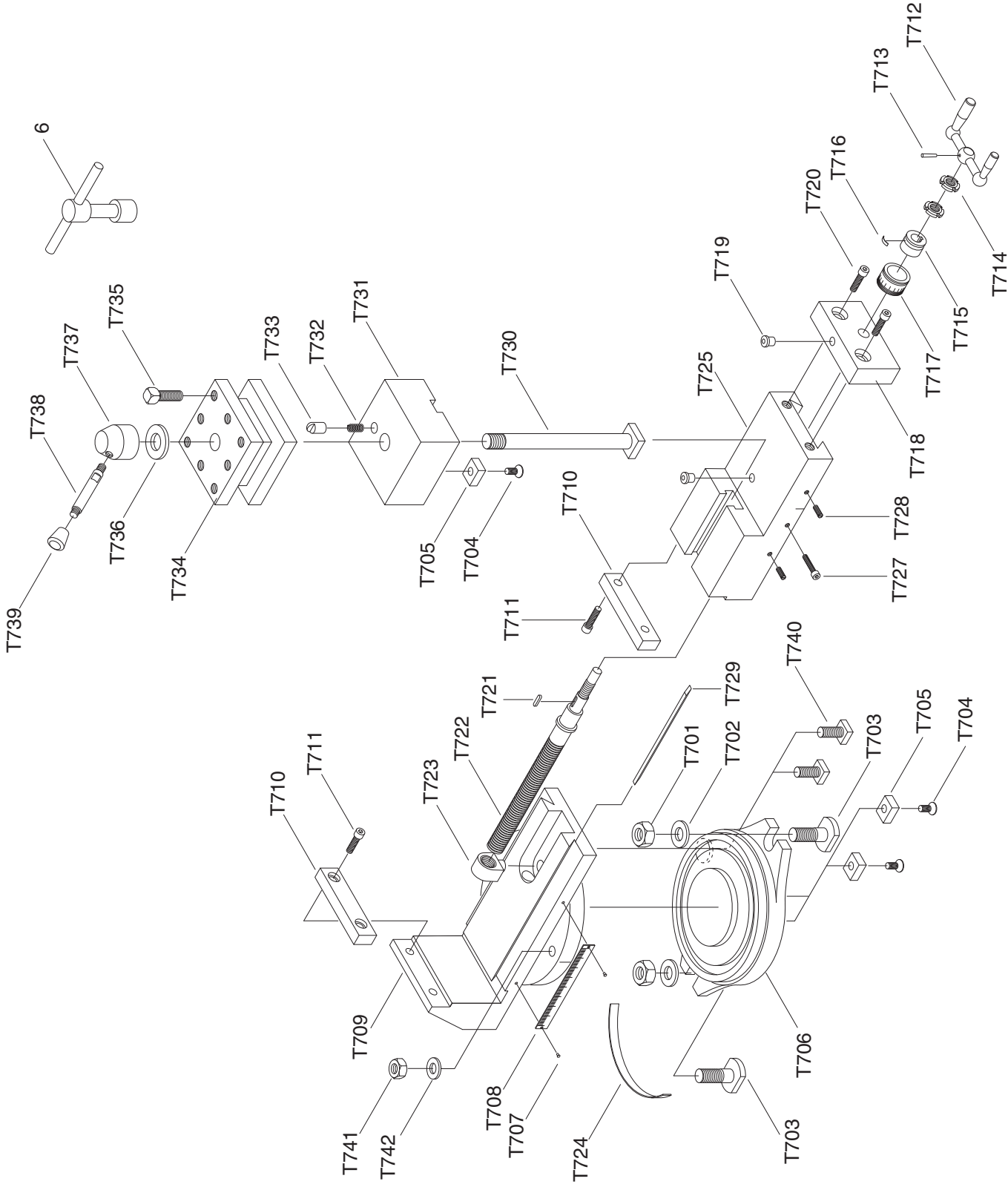

G9729 Parts Breakdown 900 Series

REF	PART #	DESCRIPTION
901	P9729901	TAILSTOCK
902	P9729902	T-KEY
903	P9729903	TAILSTOCK NUT
904	P9729904	TAILSTOCK BARREL
905	PSS52M	SET SCREW M4-.7 X 8
906	P9729906	TAILSTOCK SCREW
907	PK05M	KEY 4 X 4 X 10
908	P9729908	SPACER
909	PRP35M	ROLL PIN 5 X 10
912	P9729912	DIAL
913	P9729913	DIAL SEAT
914	P9729914	SPRING PIECE
915	P9729915	HANDWHEEL 12 X 100
916	PW04M	FLAT WASHER 10MM
917	P9729917	ACORN NUT M10-1.5
918	P9729918	HANDLE
919	P9729919	LOCKING PAD (LOWER)
920	P9729920	LOCKING PAD (UPPER)

REF	PART #	DESCRIPTION
921	P9729921	STUD M10-1.5 X 40
922	P9729922	SPACER
923	P9729923	HANDLE HUB
924	P9729924	HANDLE
925	P9729925	HANDLE KNOB M10-1.5
926	P9249002	OILER 6
927	PSS39M	SET SCREW M10-1.5 X 50
928	P9729928	LOCATING KEY
929	PFH37M	FLAT HD SCR M5-.8 X 25
930	PW04M	FLAT WASHER 10MM
931	PB31M	HEX BOLT M10-1.5 X 40
933	P9729933	QUILL SCALE
934	P9729934	RIVET
935	P9729935	LABEL
936	P9729936	CARRIAGE SCALE
937	P9729937	HANDLE SCREW M8-1.25 X 55
938	P9729938	SCALE POINTER

WARRANTY AND RETURNS

Grizzly Industrial, Inc. warrants every product it sells for a period of **1 year** to the original purchaser from the date of purchase. This warranty does not apply to defects due directly or indirectly to misuse, abuse, negligence, accidents, repairs or alterations or lack of maintenance. This is Grizzly's sole written warranty and any and all warranties that may be implied by law, including any merchantability or fitness, for any particular purpose, are hereby limited to the duration of this written warranty. We do not warrant or represent that the merchandise complies with the provisions of any law or acts unless the manufacturer so warrants. In no event shall Grizzly's liability under this warranty exceed the purchase price paid for the product and any legal actions brought against Grizzly shall be tried in the State of Washington, County of Whatcom.

We shall in no event be liable for death, injuries to persons or property or for incidental, contingent, special, or consequential damages arising from the use of our products.

To take advantage of this warranty, contact us by mail or phone and give us all the details. We will then issue you a "Return Number," which must be clearly posted on the outside as well as the inside of the carton. We will not accept any item back without this number. Proof of purchase must accompany the merchandise.

The manufacturers reserve the right to change specifications at any time because they constantly strive to achieve better quality equipment. We make every effort to ensure that our products meet high quality and durability standards and we hope you never need to use this warranty.

Please feel free to write or call us if you have any questions about the machine or the manual.

Thank you again for your business and continued support. We hope to serve you again soon.



WARRANTY CARD

Name _____
 Street _____
 City _____ State _____ Zip _____
 Phone # _____ Email _____ Invoice # _____
 Model # _____ Order # _____ Serial # _____

The following information is given on a voluntary basis. It will be used for marketing purposes to help us develop better products and services. **Of course, all information is strictly confidential.**

1. How did you learn about us?

Advertisement Friend Catalog
 Card Deck Website Other: _____

2. Which of the following magazines do you subscribe to?

<input type="checkbox"/> Cabinet Maker	<input type="checkbox"/> Popular Mechanics	<input type="checkbox"/> Today's Homeowner
<input type="checkbox"/> Family Handyman	<input type="checkbox"/> Popular Science	<input type="checkbox"/> Wood
<input type="checkbox"/> Hand Loader	<input type="checkbox"/> Popular Woodworking	<input type="checkbox"/> Wooden Boat
<input type="checkbox"/> Handy	<input type="checkbox"/> Practical Homeowner	<input type="checkbox"/> Woodshop News
<input type="checkbox"/> Home Shop Machinist	<input type="checkbox"/> Precision Shooter	<input type="checkbox"/> Woodsmith
<input type="checkbox"/> Journal of Light Cont.	<input type="checkbox"/> Projects in Metal	<input type="checkbox"/> Woodwork
<input type="checkbox"/> Live Steam	<input type="checkbox"/> RC Modeler	<input type="checkbox"/> Woodworker West
<input type="checkbox"/> Model Airplane News	<input type="checkbox"/> Rifle	<input type="checkbox"/> Woodworker's Journal
<input type="checkbox"/> Modeltec	<input type="checkbox"/> Shop Notes	<input type="checkbox"/> Other: _____
<input type="checkbox"/> Old House Journal	<input type="checkbox"/> Shotgun News	

3. What is your annual household income?

\$20,000-\$29,000 \$30,000-\$39,000 \$40,000-\$49,000
 \$50,000-\$59,000 \$60,000-\$69,000 \$70,000+

4. What is your age group?

20-29 30-39 40-49
 50-59 60-69 70+

5. How long have you been a woodworker/metalworker?

0-2 Years 2-8 Years 8-20 Years 20+ Years

6. How many of your machines or tools are Grizzly?

0-2 3-5 6-9 10+

7. Do you think your machine represents a good value?

Yes No

8. Would you recommend Grizzly Industrial to a friend?

Yes No

9. Would you allow us to use your name as a reference for Grizzly customers in your area?

Note: *We never use names more than 3 times.* Yes No

10. Comments: _____

CUT ALONG DOTTED LINE

FOLD ALONG DOTTED LINE



Place
Stamp
Here



GRIZZLY INDUSTRIAL, INC.
P.O. BOX 2069
BELLINGHAM, WA 98227-2069



FOLD ALONG DOTTED LINE

Send a Grizzly Catalog to a friend:

Name _____
Street _____
City _____ State _____ Zip _____

TAPE ALONG EDGES--PLEASE DO NOT STAPLE

grizzly.com

TOOL WEBSITE

Buy Direct and Save with Grizzly® – Trusted, Proven and a Great Value!

*Visit Our Website Today And Discover Why
Grizzly® Is The Industry Leader!*

- SECURE ORDERING
- ORDERS SHIPPED WITHIN 24 HOURS
- E-MAIL RESPONSE WITHIN ONE HOUR

-OR-

Call Today For A **FREE**
Full Color Catalog

1-800-523-4777

