

# READ THIS FIRST



Model G8144Z/G8145Z/G8146Z

**\*\*\*IMPORTANT UPDATE\*\*\***

For Machines Mfd. Since 02/22  
and Owner's Manual Revised 06/11

For questions or help with this product contact Tech Support at (570) 546-9663 or [techsupport@grizzly.com](mailto:techsupport@grizzly.com)

The following changes were recently made since the owner's manual was printed:

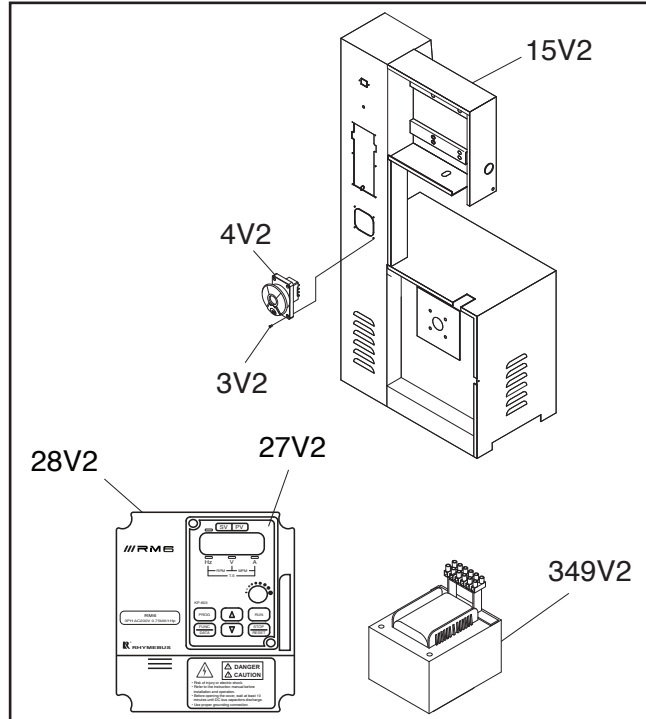
- Inverter and Digital Display have changed (all models).
- ON/OFF Switch has changed (G8144Z/G8145Z only).
- Transformer has changed (all models).
- Test Run steps have been updated (all models).
- Wiring diagrams have been updated (all models).
- The wiring diagrams and photos in this update replace ALL those shown in prior updates and manual.

Aside from this information, all other content in the owner's manual applies and **MUST** be read and understood for your own safety. **IMPORTANT: Keep this update with the owner's manual for future reference.**

For questions or help, contact our Tech Support at (570) 546-9663 or [techsupport@grizzly.com](mailto:techsupport@grizzly.com).

## Revised Parts

G8144Z/G8145Z Model Shown



### G8144Z

REF	PART #	DESCRIPTION
3V2	P8144Z003V2	PHLP HD SCR M4-.7 X 25 V2.04.22
4V2	P8144Z004V2	ON/OFF BUTTON W/DISABLE KEY V2.04.22
15V2	P8144Z015V2	BANDSAW CABINET V2.04.22
27V2	P8144Z027V2	DIGITAL DISPLAY KP-603A V2.02.20
28V2	P8144Z028V2	INVERTER RM6-2001B3 1HP 220V V2.02.20
349V2	P8144Z349V2	TRANSFORMER 1.2KVA 220V V2.05.18 (G8144Z)

### G8145Z

REF	PART #	DESCRIPTION
3V2	P8145Z003V2	PHLP HD SCR M4-.7 X 25 V2.04.22
4V2	P8145Z004V2	ON/OFF BUTTON W/DISABLE KEY V2.04.22
15V2	P8145Z015V2	BANDSAW CABINET V2.04.22
27V2	P8145Z027V2	DIGITAL DISPLAY KP-603A V2.02.20
28V2	P8145Z028V2	INVERTER RM6-2001B3 1HP 220V V2.02.20
349V2	P8145Z349V2	TRANSFORMER 2.4KVA 220V V2.05.18 (G8145Z)

### G8146Z

REF	PART #	DESCRIPTION
27V2	P8146Z027V2	DIGITAL DISPLAY KP-603A V2.02.20
28V2	P8146Z028V2	INVERTER RM6-2002B3 2HP 220V V2.02.20
349V2	P8146Z349V2	TRANSFORMER 4.2KVA 220V V2.05.18 (G8146Z)

COPYRIGHT © OCTOBER, 2021 BY GRIZZLY INDUSTRIAL, INC., REVISED MARCH, 2022 (JP)  
**WARNING: NO PORTION OF THIS MANUAL MAY BE REPRODUCED IN ANY SHAPE OR FORM WITHOUT THE WRITTEN APPROVAL OF GRIZZLY INDUSTRIAL, INC.**

#JP22070 PRINTED IN TAIWAN

## Old Inverter

All Models



## New Inverter & Digital Display



## Old ON/OFF Switch

G8144Z/G8145Z Only

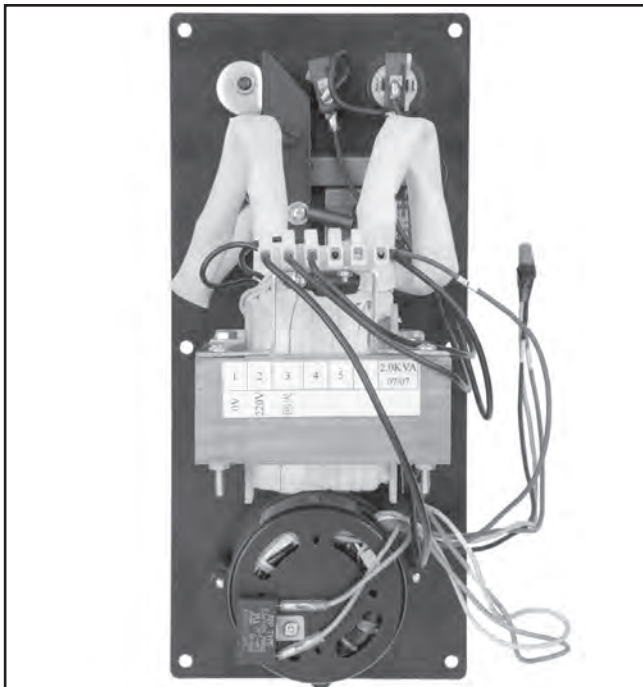


## New ON/OFF Switch

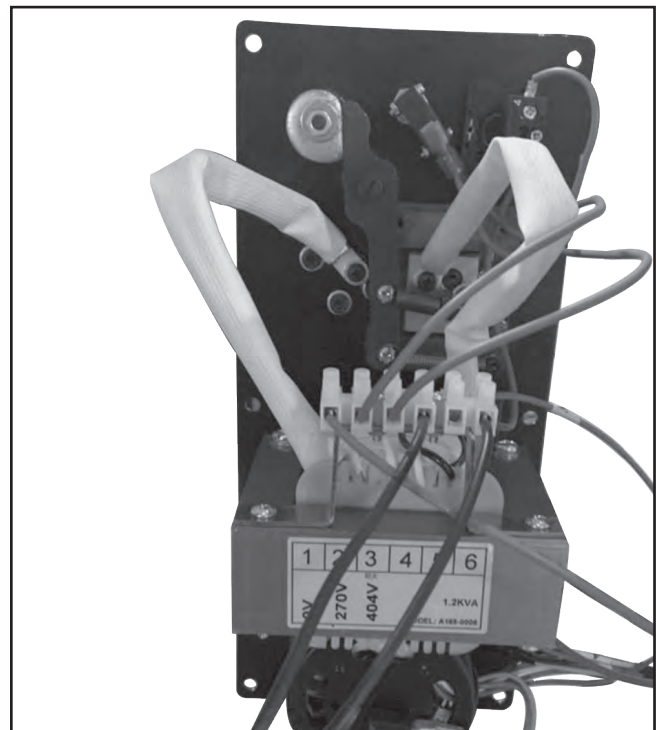


## Old Transformer

All Models



## New Transformer



(Replaces Page 19 in Manual)

2. Unbolt bandsaw from pallet.
3. With two assistants to steady the bandsaw, slowly lift it just enough to clear the pallet and floor obstacles, then move it to the prepared location.
4. Use shims between machine mounting flanges and floor to level bandsaw.

**Note:** *Tighten the mounting fasteners evenly to avoid warping or cracking the cast iron base.*

## Test Run

Once assembly is complete, test run the machine to ensure it is properly connected to power and safety components are functioning correctly.

If you find an unusual problem during the test run, immediately stop the machine, disconnect it from power, and fix the problem BEFORE operating the machine again. The **Troubleshooting** table in the **SERVICE** section of this manual can help.

The Test Run consists of verifying the following:  
1) The motor powers up and runs correctly, and  
2) the switch disabling key disables the switch properly.

### WARNING

Serious injury or death can result from using this machine BEFORE understanding its controls and related safety information. DO NOT operate, or allow others to operate, machine until the information is understood.

### WARNING

DO NOT start machine until all preceding setup instructions have been performed. Operating an improperly set up machine may result in malfunction or unexpected results that can lead to serious injury, death, or machine/property damage.

#### To test run machine:

1. Clear all tools and objects used during setup away from machine.
2. Make sure blade is properly tensioned and blade guides are positioned correctly (refer to **Blade Tensioning** on **Page 29** in **Manual**, and **Adjusting Blade Guides** on **Page 31** in **Manual** for detailed instructions).

3. **Models G8144Z/G8145Z:** Push ON/STOP button in.

**Model G8146Z:** Push Emergency Stop button in.

4. Connect machine to power source.
5. **Models G8144Z/G8145Z:** Pull ON/STOP button out to turn machine **ON**.

#### Model G8146Z:

- a. Place key in Power Switch and turn it to the ON position—the Power Lamp should light.

- b. Twist Emergency Stop button clockwise so it pops out. When Emergency Stop button pops out, the switch is reset and ready for operation.

- c. Push Start button to turn machine **ON**.

6. Verify machine is operating correctly.

—When operating correctly, the machine runs smoothly with little or no vibration or rubbing noises.

—Investigate and correct strange or unusual noises or vibrations before operating the machine further. Always disconnect the machine from power when investigating or correcting potential problems.



(Replaces Page 20 in Manual)

7. Verify motor is running in the correct direction.

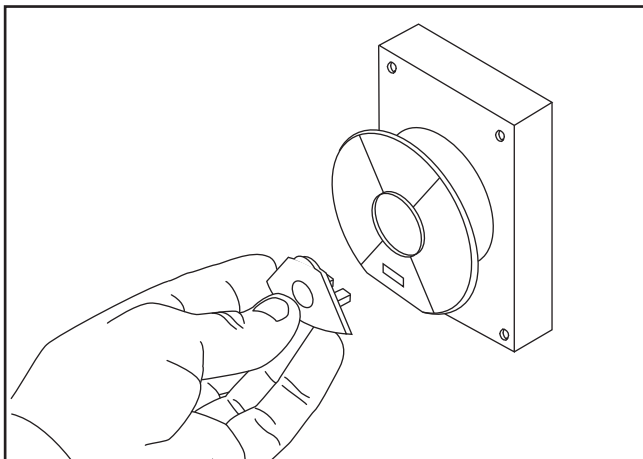
—When the motor *is* running in the correct direction, the blade will be moving down into the table.

—If the motor *is not* running in the correct direction, stop the machine, disconnect the machine from power, and switch any two incoming power leads inside the motor wiring junction box (refer to **Motor Wiring Diagram** on **Page 10** for detailed illustrations).

8. Models G8144Z/G8145Z:

a. Press ON/STOP button to turn machine **OFF**.

b. Remove ON/STOP button disabling key, as shown in **Figure 1**.



**Figure 1.** Example of removing disabling key from ON/STOP button.

c. Pull the ON/STOP button out to try to turn the machine **ON**.

—If the machine *does not* start, the switch safety feature is working correctly. Congratulations, test run is complete!

—If the machine *does* start, switch safety feature is not working correctly. This safety feature must work properly before proceeding with regular operations. Disconnect machine from power and call Tech Support for help.

**Model 8146Z:**

a. Press Emergency Stop button to stop machine.

b. **WITHOUT** resetting Emergency Stop button, press Start button. The machine should not start.

—If the machine *does not* start, the Emergency Stop button safety feature is working correctly.

—If the machine *does* start (with the Stop button pushed in), immediately disconnect power to the machine. The Emergency Stop button safety feature is not working correctly. This safety feature must work properly before proceeding with regular operations. Call Tech Support for help.

c. Reset Emergency Stop button by twisting it clockwise until it pops out.

d. Turn the Power Switch key to the OFF position—the Power Lamp should go out.

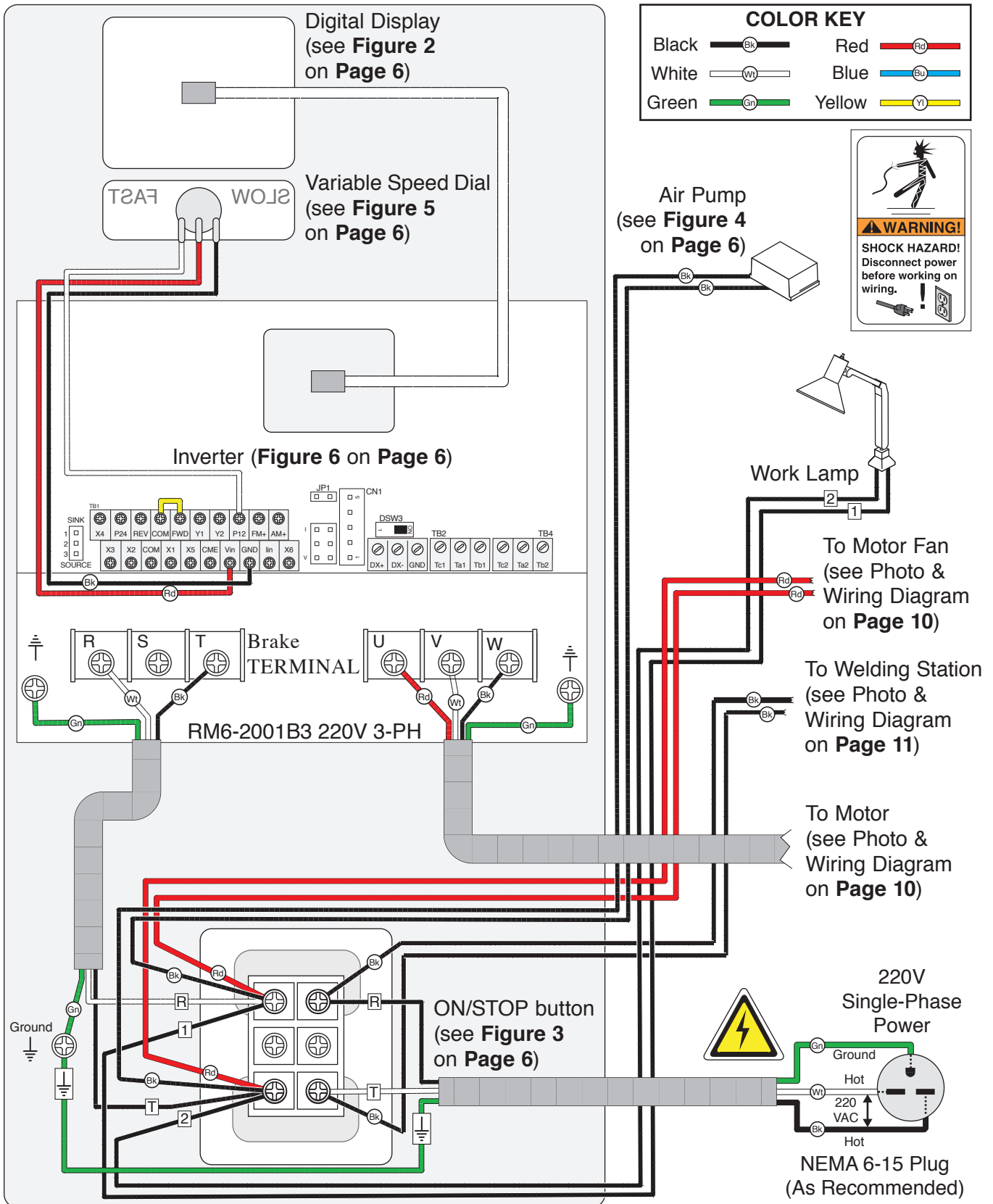
e. Press the Start button.

—If the machine *does not* start, the Power Switch safety feature is working correctly. Congratulations, the Test Run is complete!

—If the machine *does* start (with the Power Switch key turned to OFF position), immediately disconnect power to the machine. The Power Switch safety feature is not working correctly. This safety feature must work properly before proceeding with regular operations. Call Tech Support for help.



# G8144Z/G8145Z Control Panel & Inverter Wiring Diagram



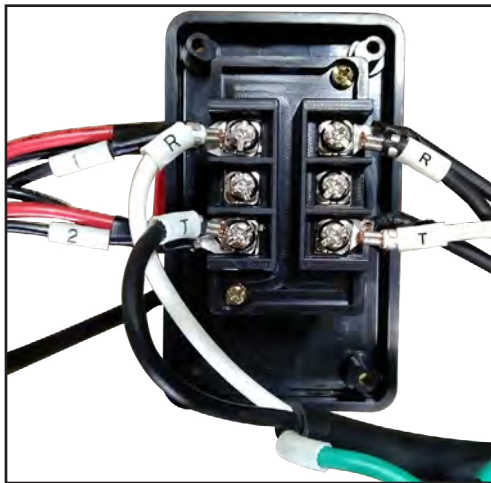
# G8144Z/G8145Z Electrical Components



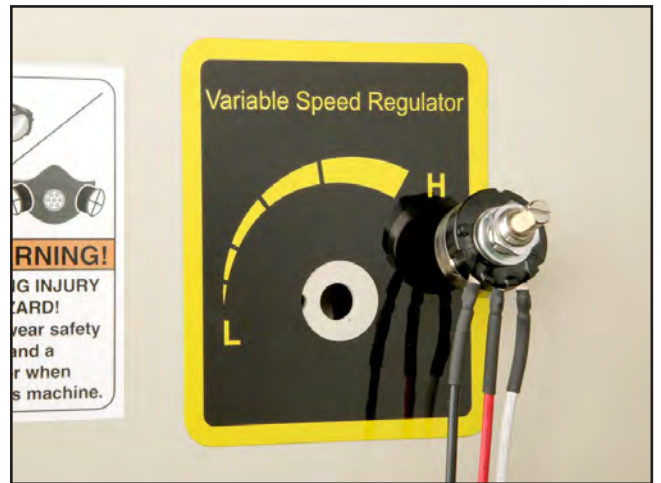
**Figure 2.** Digital display (see wiring diagram on Page 5).



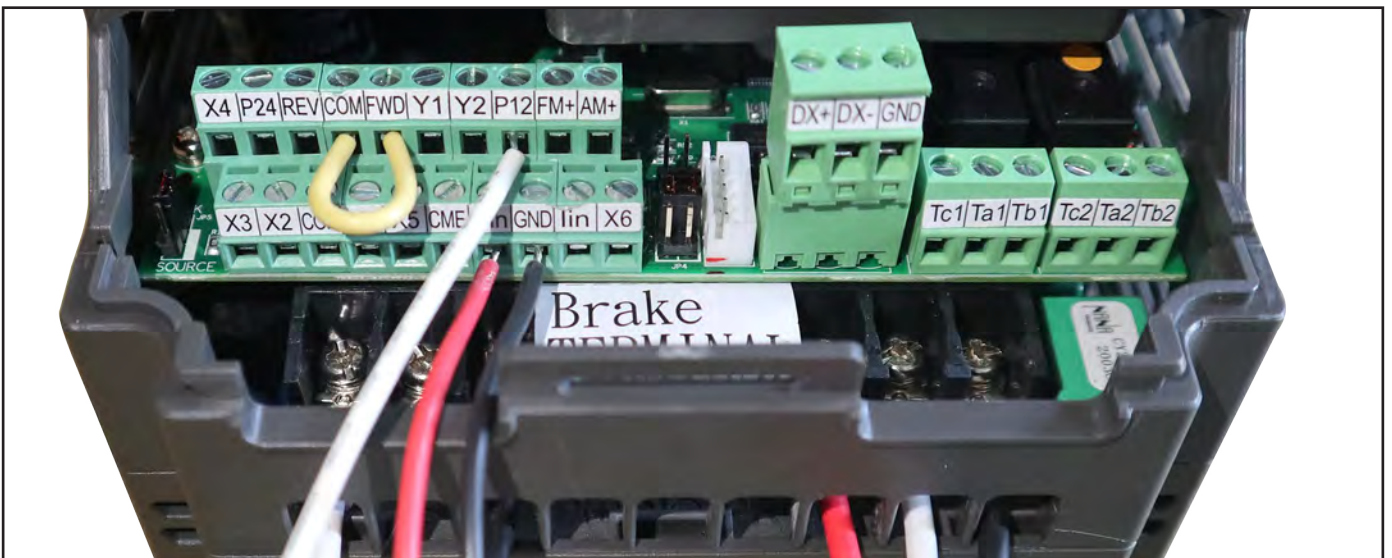
**Figure 4.** Air pump wiring (see wiring diagram on Page 5).



**Figure 3.** ON/STOP button wiring (see wiring diagram on Page 5).



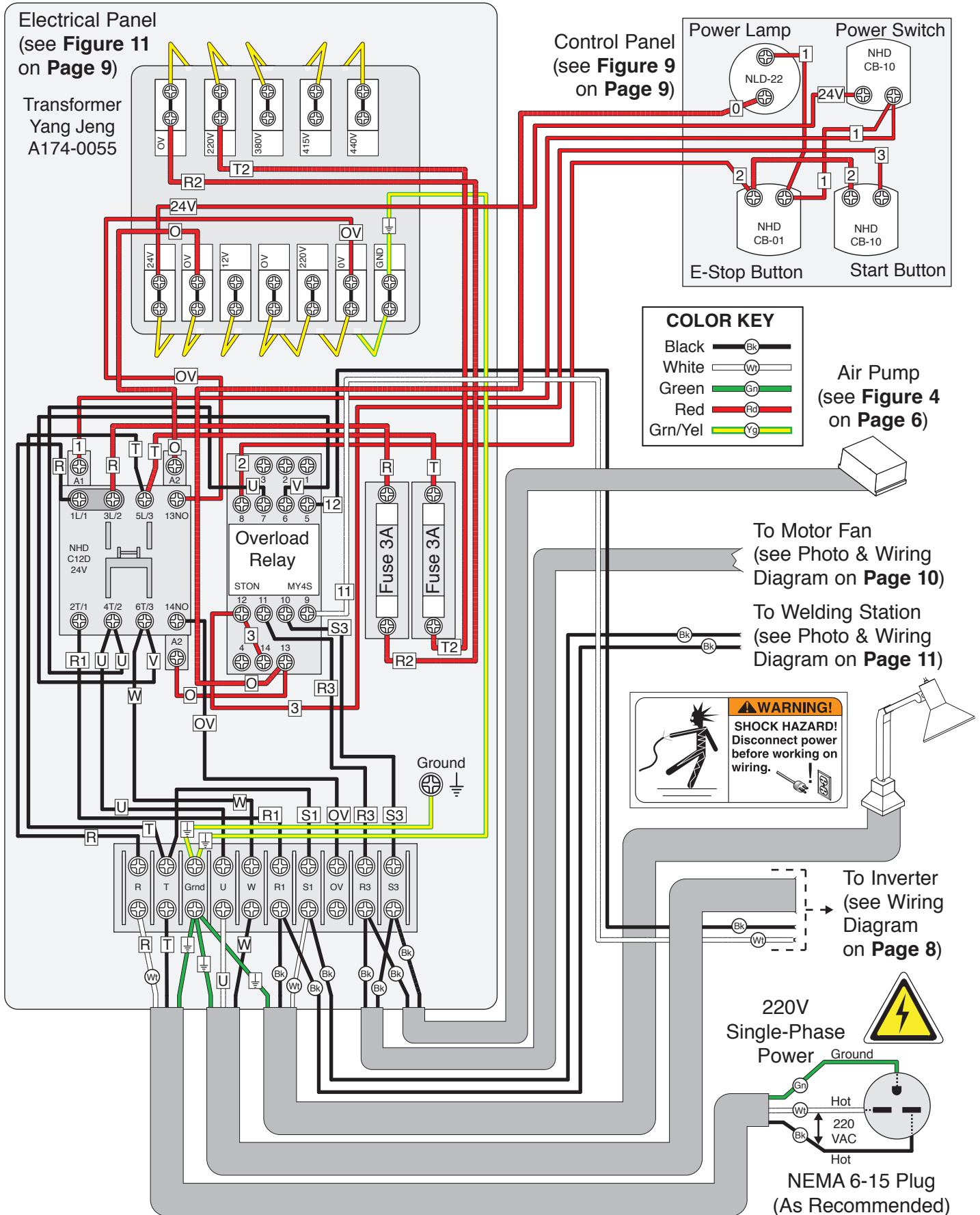
**Figure 5.** Variable speed dial wiring (see wiring diagram on Page 5).



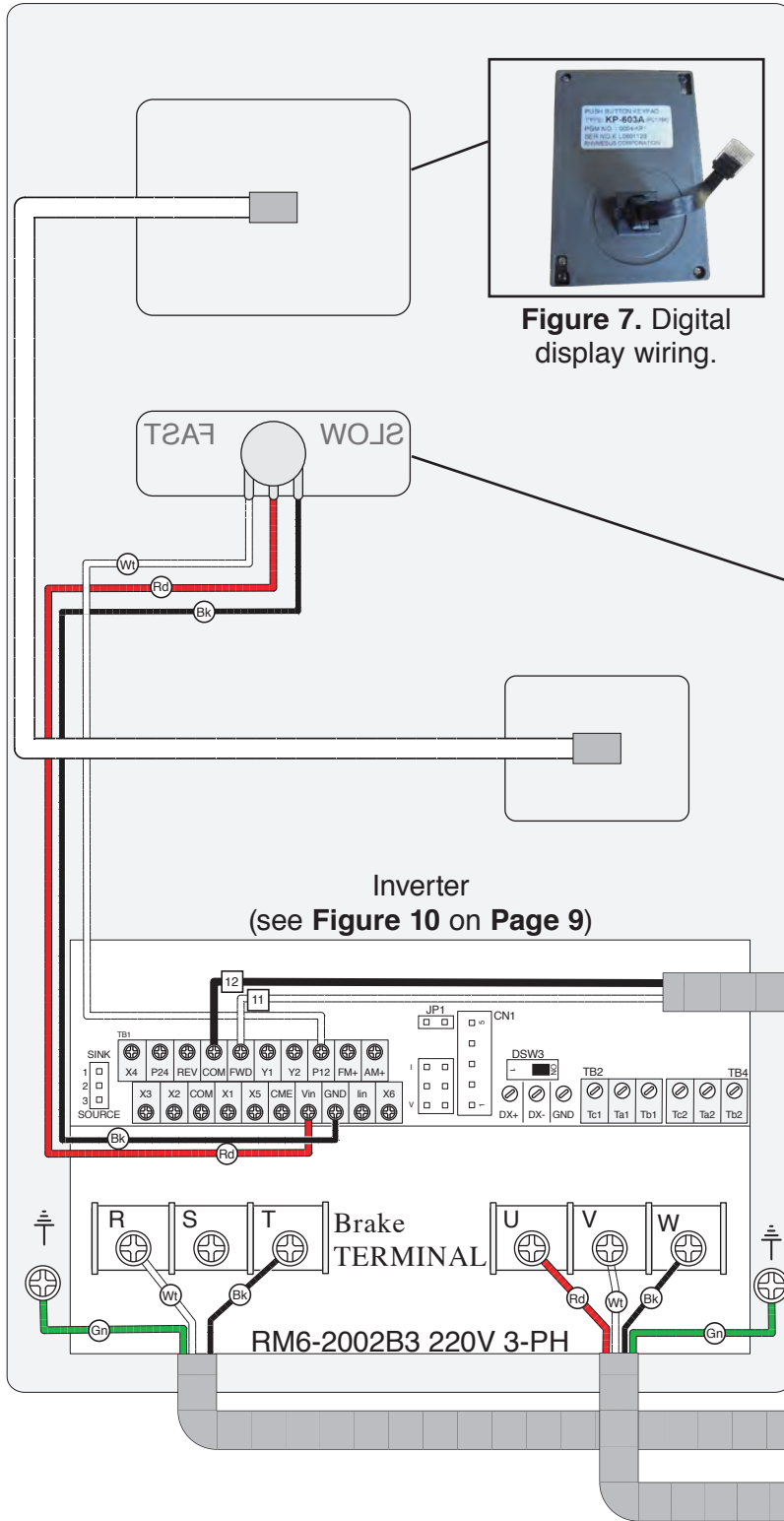
**Figure 6.** Inverter/controller box wiring (see wiring diagram on Page 5).



# G8146Z Electrical & Control Wiring Diagram



# G8146Z Inverter Wiring Diagram



COLOR KEY			
Black		Red	
White		Blue	
Green		Yellow	

**⚠ WARNING!**  
**SHOCK HAZARD!**  
 Disconnect power before working on wiring.



**Figure 8.** Variable speed dial wiring.

To Electrical Panel  
 (see **Figure 11** on **Page 9**, Wiring Diagram on **Page 7**)

To Motor  
 (see Photo & Wiring Diagram on **Page 10**)



# G8146Z Electrical Components

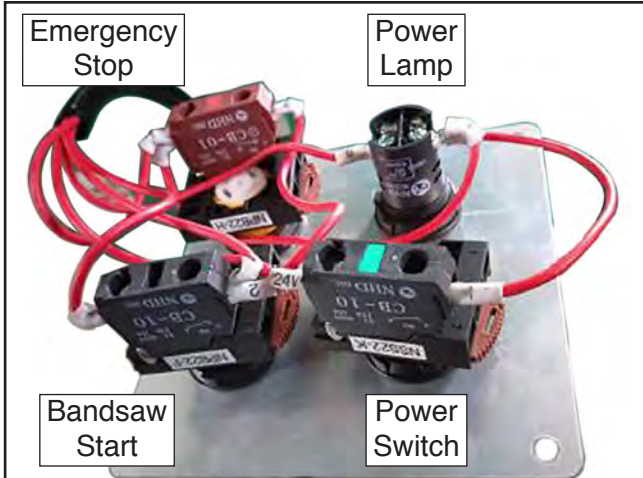


Figure 9. Control panel wiring (see wiring diagram on Page 7).

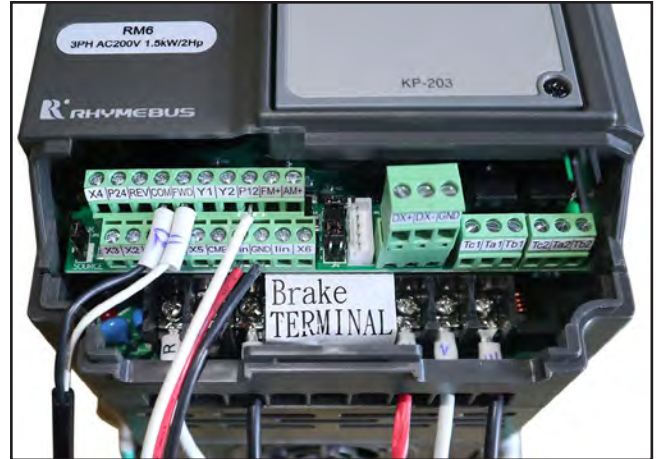


Figure 10. Inverter/Controller box wiring (see wiring diagram on Page 8).

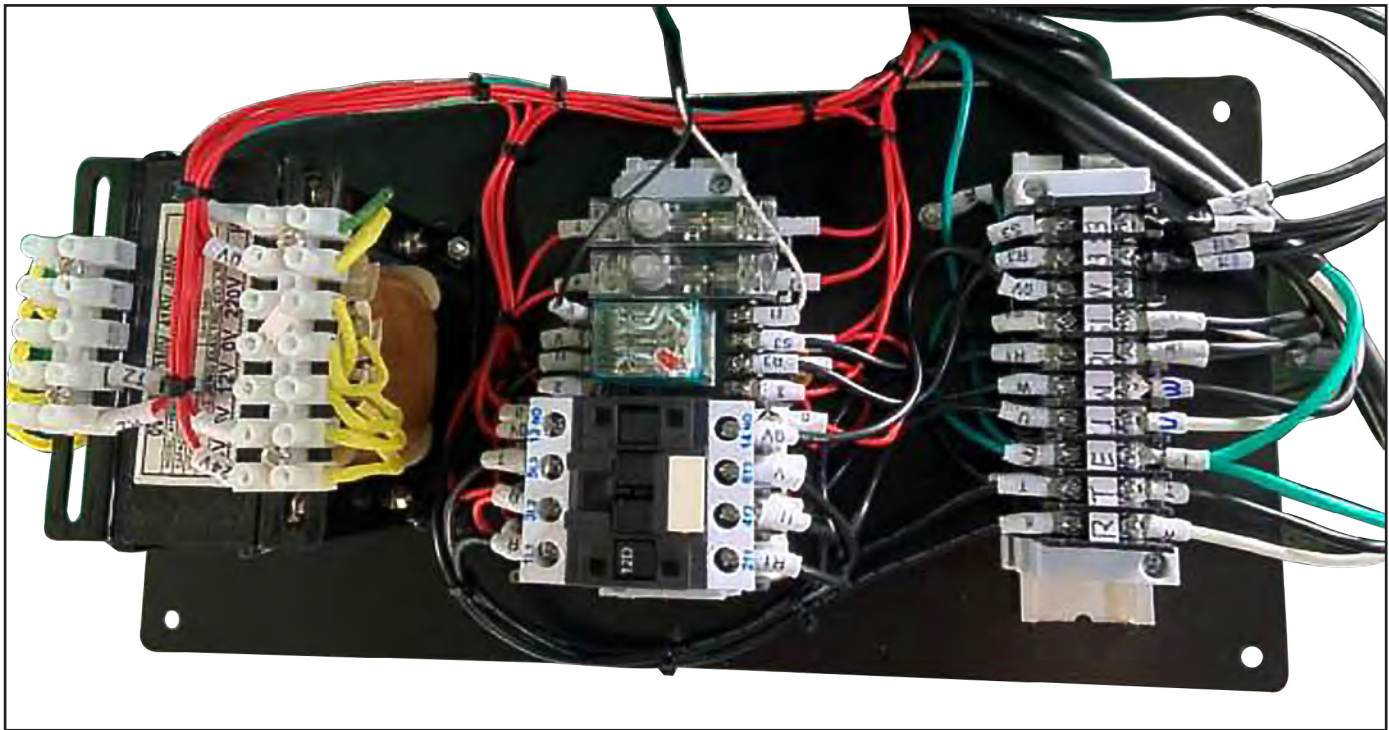


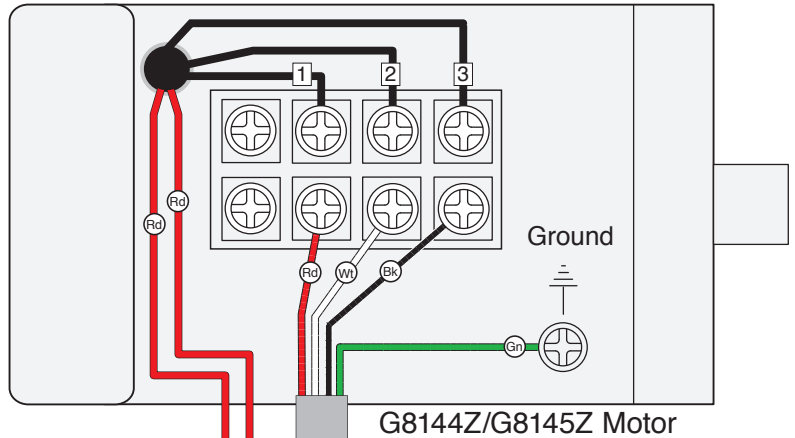
Figure 11. Main electrical wiring (see wiring diagram on Page 7).



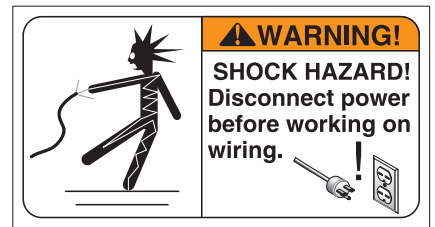
# Motor Wiring Diagram



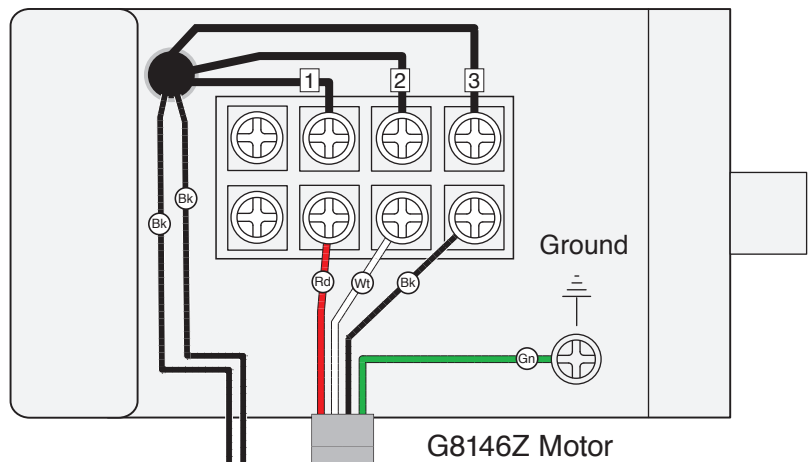
**Figure 12.** G8144Z/G8145Z motor junction box wiring.



Motor Fan Wiring  
**G8144Z/G8145Z:**  
 To Control Panel  
 & Inverter  
 (see **Page 5**)



**Figure 13.** G8146Z motor junction box wiring.



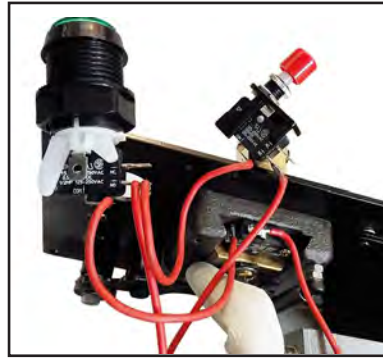
Motor Fan Wiring  
**G8146Z:** To Inverter  
 (see **Page 8**) &  
 Electrical Panel  
 (see **Page 7**)

**MOTOR DIRECTION**  
**NOTICE**  
 If motor rotates in opposite direction, swap any two power source wires at the incoming terminals.

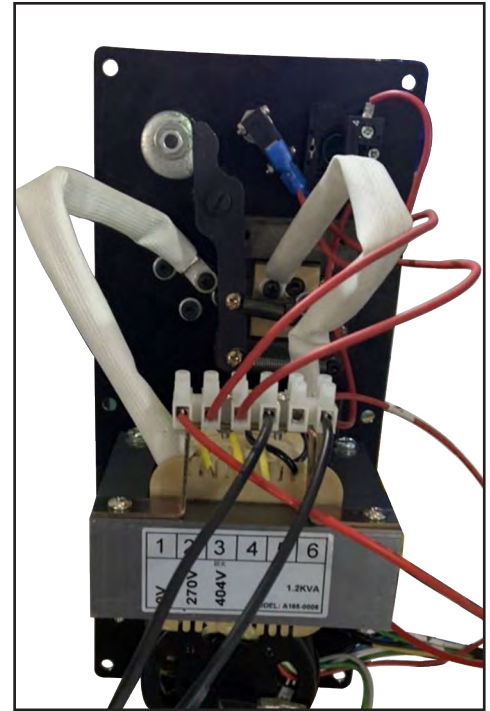
COLOR KEY	
Black	— Bk —
White	— Wt —
Green	— Gn —
Red	— Rd —



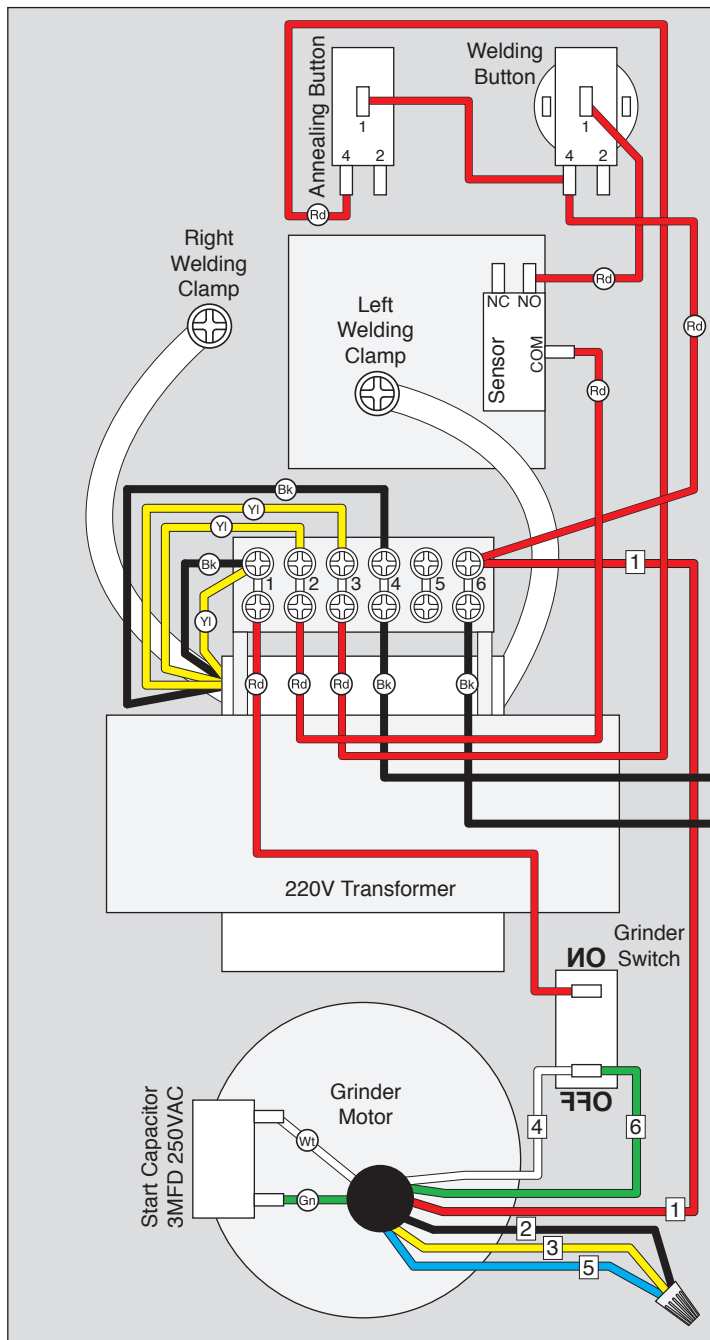
# Welding Station Wiring (All Models)



**Figure 14.** Annealing and welding buttons.



**Figure 15.** Welding station wiring (model G8144Z shown).



**G8144Z/G8145Z:**  
 To ON/STOP button  
 (see Page 5).

**G8146Z:**  
 To Electrical Panel  
 (see Page 7).

COLOR KEY			
Black		Red	
White		Blue	
Green		Yellow	



# *grizzly.com*<sup>®</sup>

**TOOL WEBSITE**

Buy Direct and Save with Grizzly<sup>®</sup> – Trusted, Proven and a Great Value!  
~Since 1983~

*Visit Our Website Today For  
Current Specials!*

**ORDER  
24 HOURS A DAY!  
1-800-523-4777**



# READ THIS FIRST



Models G8144Z/G8145Z/G8146Z

**\*\*\*IMPORTANT UPDATE\*\*\***

For Machines Mfd. Since 08/18  
and Owner's Manual Revised 06/11

For questions or help with this product contact Tech Support at (570) 546-9663 or [techsupport@grizzly.com](mailto:techsupport@grizzly.com)

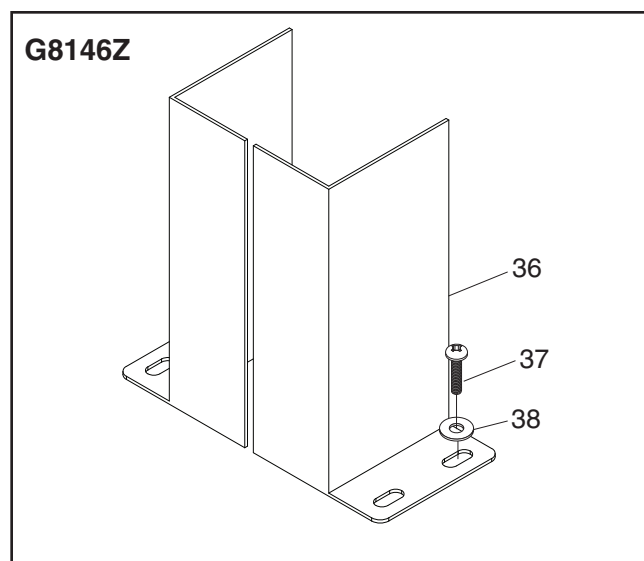
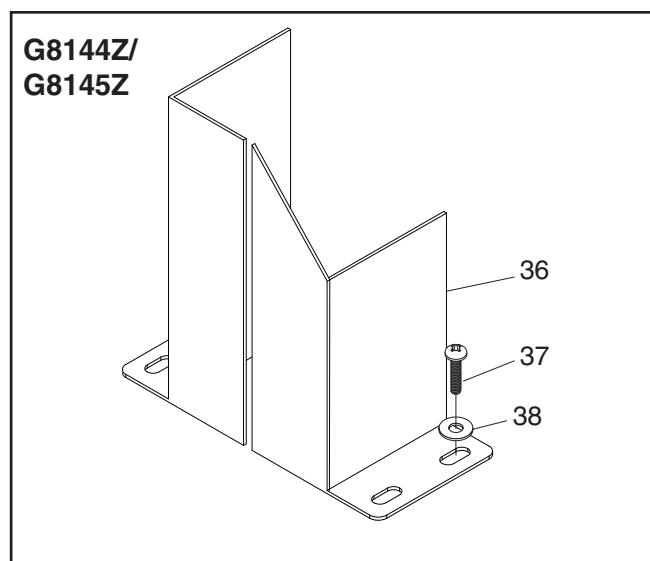
The following changes were recently made since the owner's manual was printed:

- Added lower blade guards for each model. G8144Z and G8145Z use same angled guard. G8146Z uses rectangular guard.

Aside from this information, all other content in the owner's manual applies and **MUST** be read and understood for your own safety. **IMPORTANT: Keep this update with the owner's manual for future reference.**

For questions or help, contact our Tech Support at (570) 546-9663 or [techsupport@grizzly.com](mailto:techsupport@grizzly.com).

## New Parts



REF	PART #	DESCRIPTION
36	P8144Z036	LOWER BLADE GUARD SET (G8144Z/45Z)
36	P8146Z036	LOWER BLADE GUARD SET (G8146Z)
37	P8144Z037	PHLP HD SCR M6-1 X 10
38	P8144Z038	FLAT WASHER 6MM

COPYRIGHT © MAY 2019 BY GRIZZLY INDUSTRIAL, INC.  
**WARNING: NO PORTION OF THIS MANUAL MAY BE REPRODUCED IN ANY SHAPE  
OR FORM WITHOUT THE WRITTEN APPROVAL OF GRIZZLY INDUSTRIAL, INC.**  
#JL20399 PRINTED IN TAIWAN



**Model G8144Z-46Z**  
**\*\*\*IMPORTANT UPDATE\*\*\***  
 Applies to Models Mfd. Since 06/08  
 and Owner's Manual Printed 06/11

We recently made the following changes to the Model G8144Z/G8145Z/G8146Z:

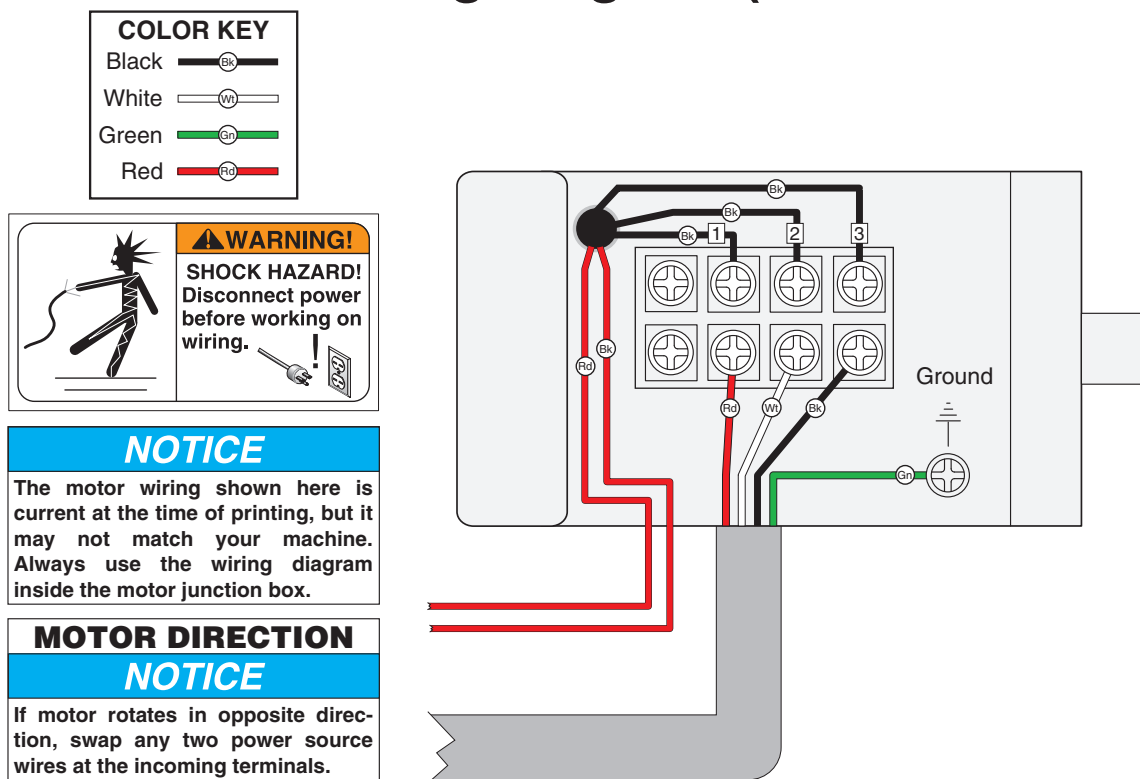
- Changed welding station wiring.
- Changed motor, control panel, inverter, and air pump wiring (Models G8144Z and G8145Z only).
- Changed to control panel components, transformer, and overload relay (Model G8146Z only).

This change does not affect how the machine assembles or functions.

Aside from the information contained in this update, all other content in the owner's manual applies to this machine. For your own safety, you **MUST** read and understand this update and the applicable owner's manual. **Keep this update for future reference!**

If you have any further questions about this manual update or the changes made to the machine, contact our Technical Support at (570) 546-9663 or email [techsupport@grizzly.com](mailto:techsupport@grizzly.com).

## Updated Motor Wiring Diagram (G8144Z & G8145Z)



COPYRIGHT © JANUARY, 2017 BY GRIZZLY INDUSTRIAL, INC., REVISED 01.17 (JH)  
**WARNING: NO PORTION OF THIS MANUAL MAY BE REPRODUCED IN ANY SHAPE OR FORM WITHOUT THE WRITTEN APPROVAL OF GRIZZLY INDUSTRIAL, INC.**  
 #TS14269 PRINTED IN TAIWAN





[Replaces Figure 60 on Page 47]

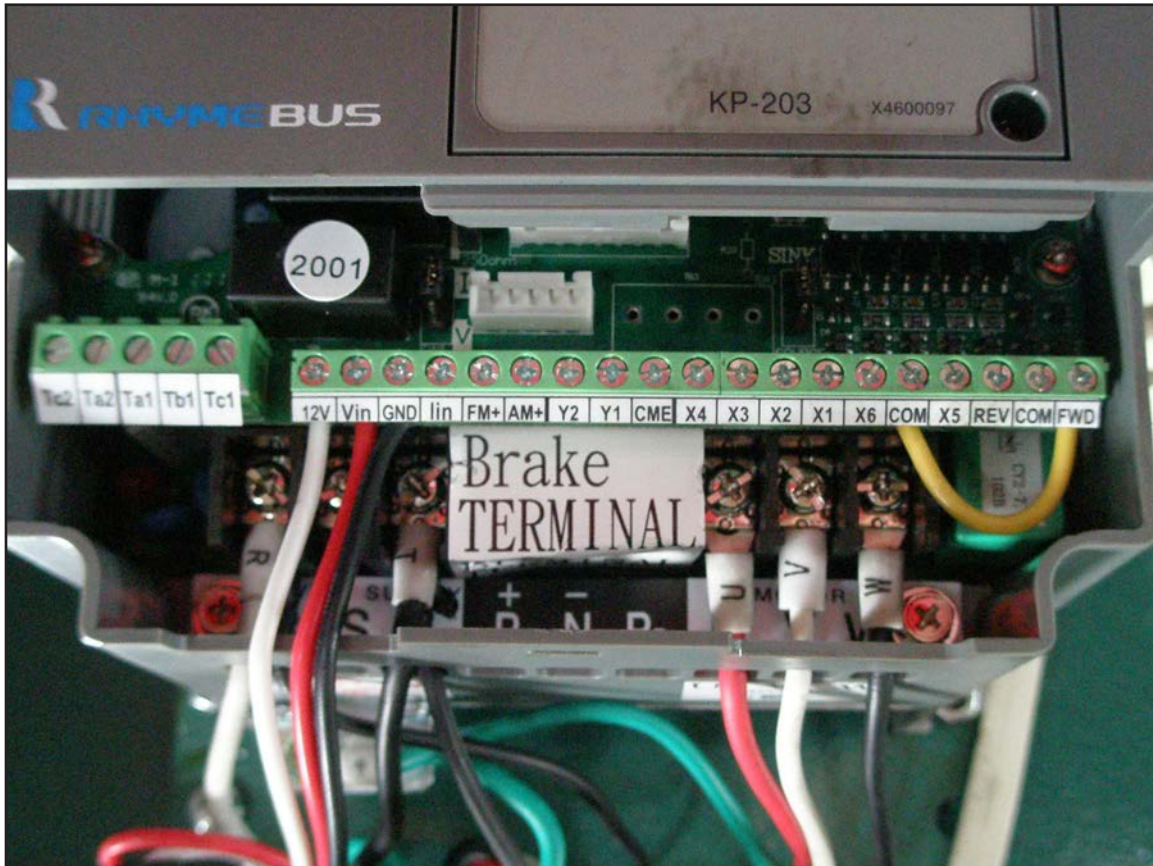
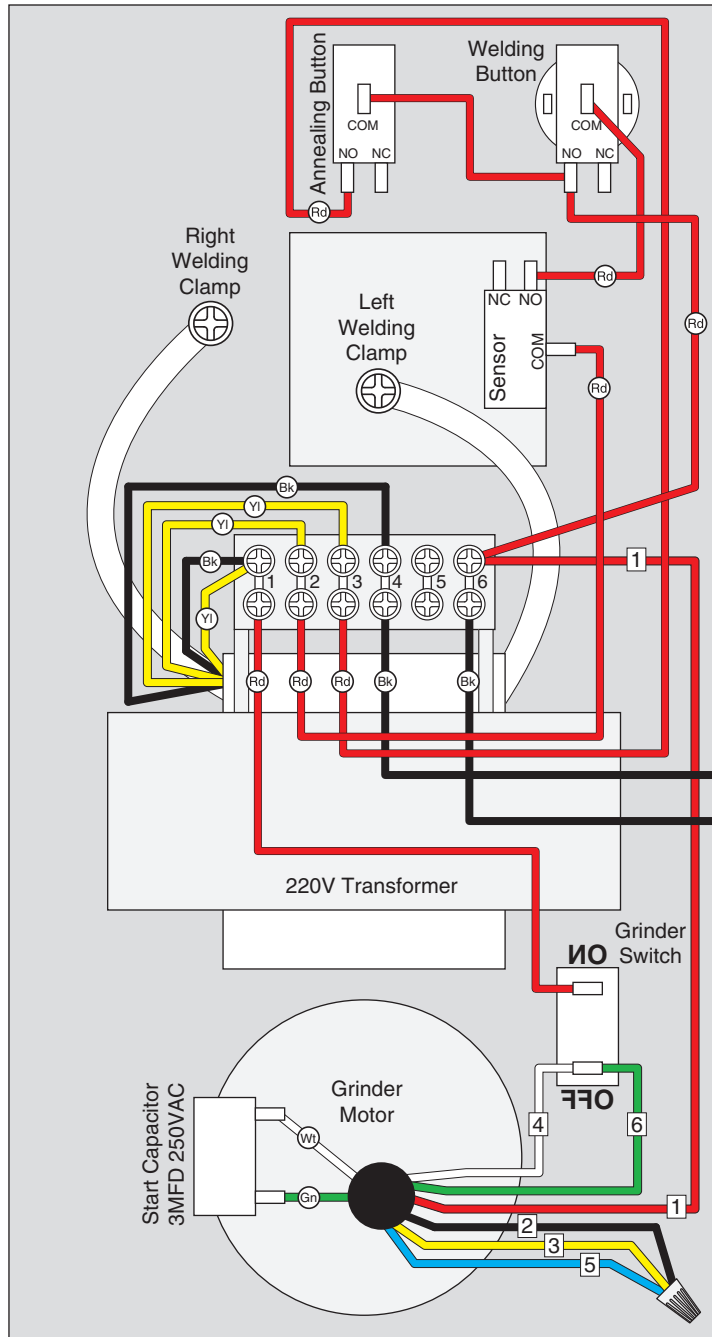


Figure 1. New inverter wiring.



# Updated Welding Station Wiring (All Models)



**COLOR KEY**

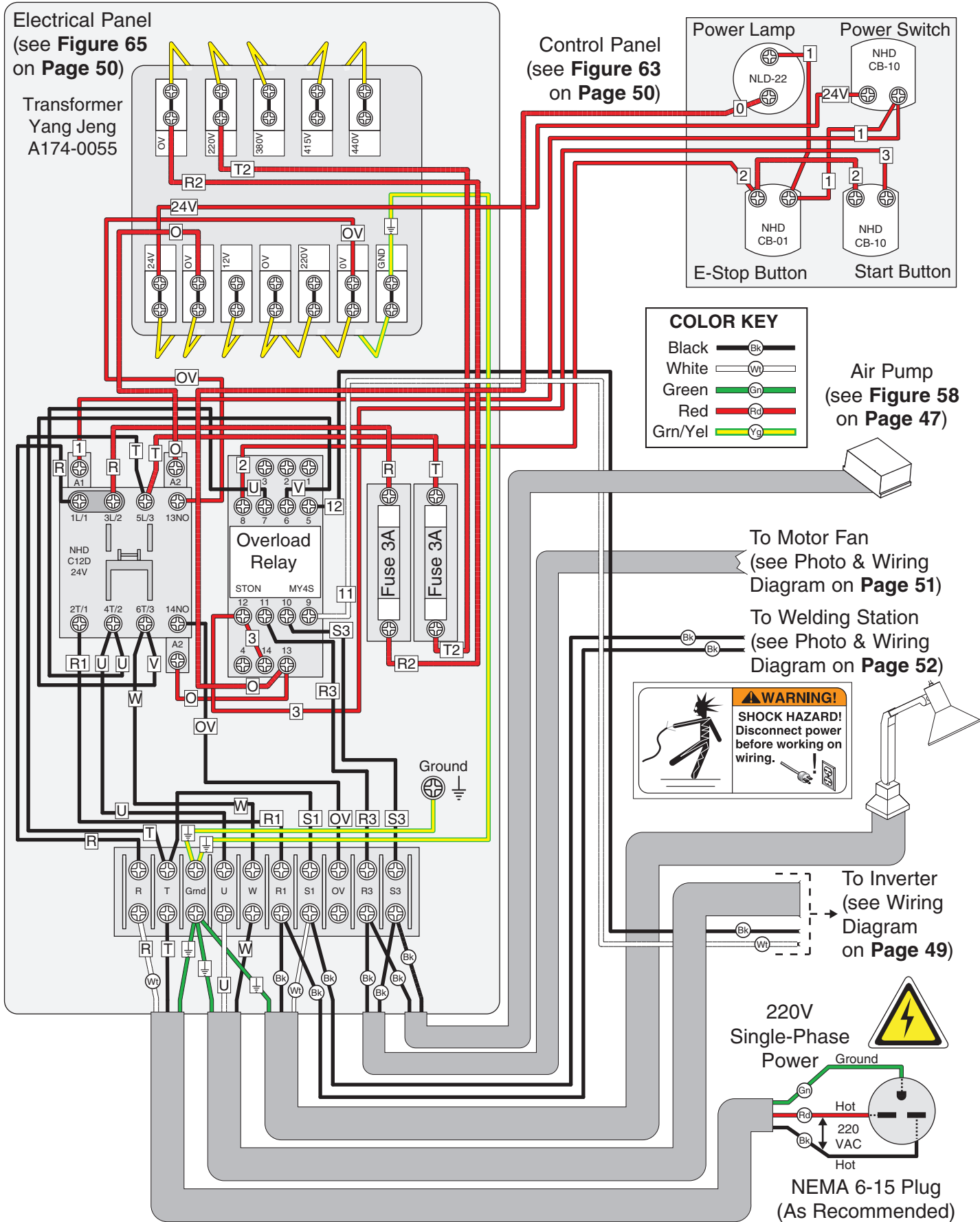
Black		Red	
White		Blue	
Green		Yellow	

**G8144Z/G8145Z:**  
To Start/Stop Switch

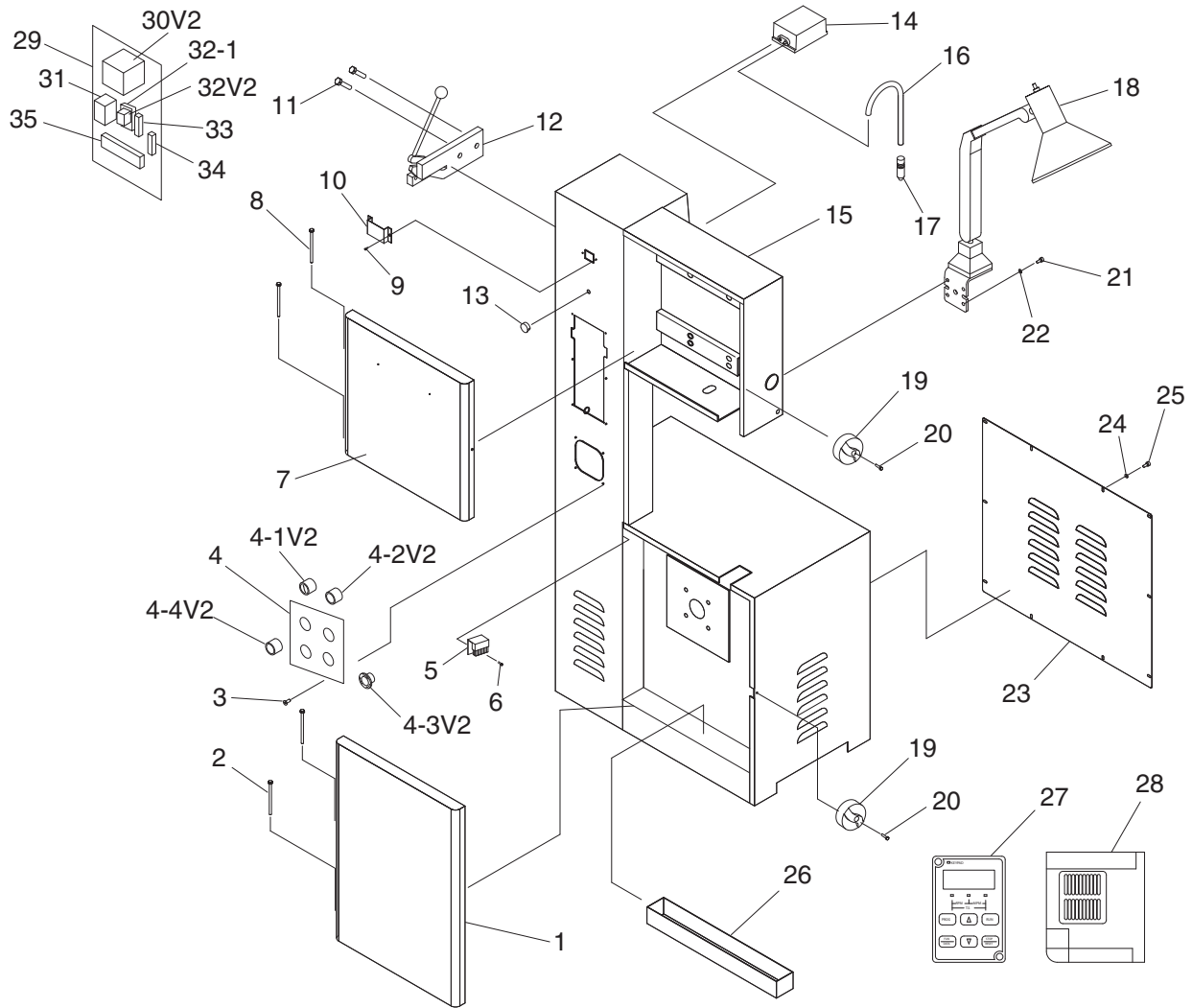
**G8146Z:**  
To Electrical Panel



# G8146Z Electrical & Control Wiring Diagram



# Updated G8146Z Cabinet Parts

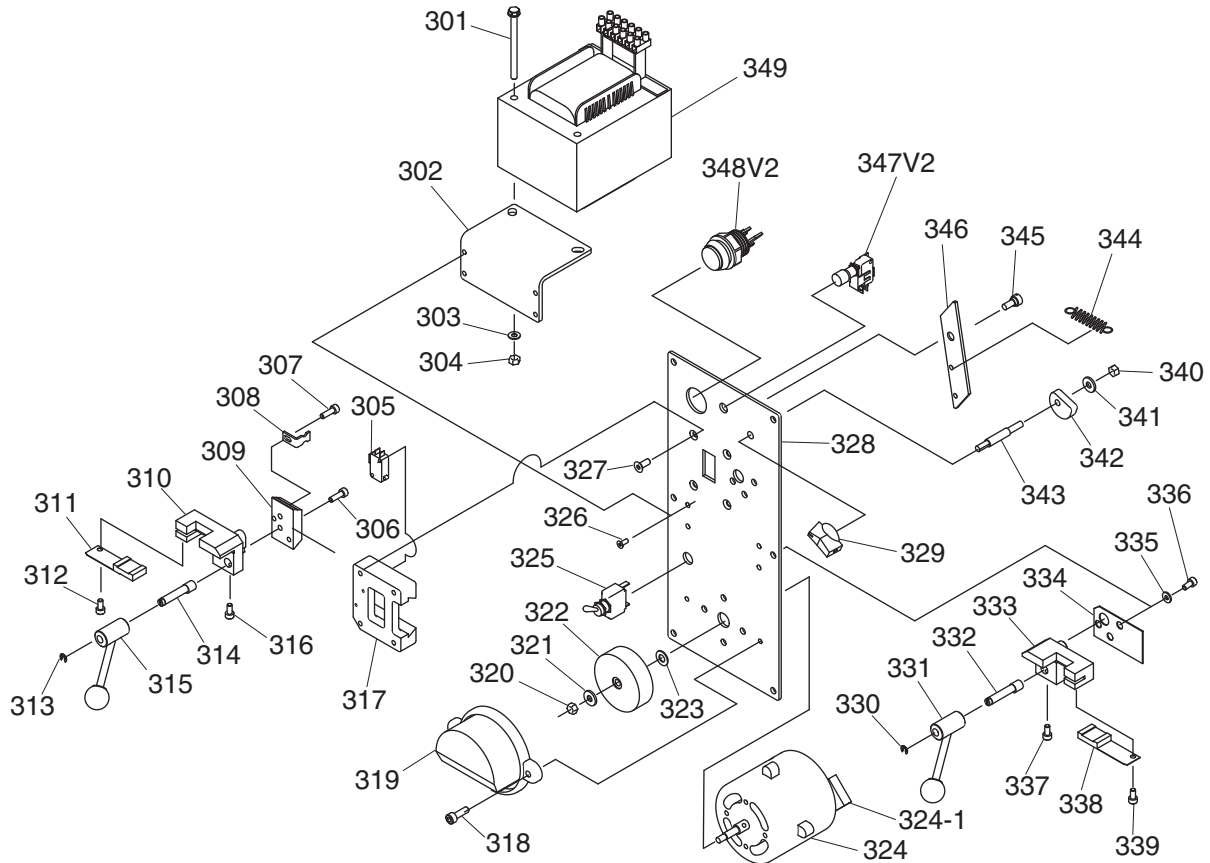


REF	PART #	DESCRIPTION
1	P8146Z001	WHEEL DOOR LOWER
2	P8146Z002	HINGE PIN LOWER
3	P8146Z003	PHLP HD SCR M5-.8 X 8
4	P8146Z004	CONTROL PANEL
4-1V2	P8146Z004-1V2	POWER SWITCH W/KEY NHD CB-10
4-2V2	P8146Z004-2V2	POWER LAMP NLD-22
4-3V2	P8146Z004-3V2	E-STOP BUTTON NHD CB-01
4-4V2	P8146Z004-4V2	BUTTON SWITCH NHD CB-10 GRN
5	P8146Z005	BLADE CLEANING BRUSH
6	P8146Z006	PHLP HD SCR M5-.8 X 25
7	P8146Z007	WHEEL DOOR UPPER
8	P8146Z008	HINGE PIN UPPER
9	P8146Z009	PHLP HD SCR M5-.8 X 8
10	P8146Z010	DIGITAL DISPLAY BRACKET
11	P8146Z011	CAP SCREW M8-1.25 X 16
11V2	P8146Z011V2	HEX BOLT M8-1.25 X 12
12	P8146Z012	BLADE SHEAR V1
12V2	P8146Z012V2	BLADE SHEAR V2.02.13
13	P8146Z013	VARIABLE SPEED DIAL
14	P8146Z014	AIR PUMP
15	P8146Z015	BANDSAW CABINET

REF	PART #	DESCRIPTION
16	P8146Z016	AIR HOSE 4X6MM
17	P8146Z017	AIR NOZZLE
18	P8146Z018	WORK LAMP 220V
19	P8146Z019	DOOR KNOB
20	P8146Z020	PHLP HD SCR M6-1 X 25
21	P8146Z021	CAP SCREW M6-1 X 15
22	P8146Z022	FLAT WASHER 6MM
23	P8146Z023	MOTOR ACCESS PANEL
24	P8146Z024	FLAT WASHER 6MM
25	P8146Z025	PHLP HD SCR M6-1 X 10
26	P8146Z026	CHIP PAN
27	P8146Z027	DIGITAL DISPLAY
28	P8146Z028	INVERTER RM5G 2HP 220V 3PH
29	P8146Z029	CONTROL PANEL
30V2	P8146Z030V2	TRANSFORMER 100VA 220V/440V-12V/220V V2.01.13
31	P8146Z031	CONTACTOR NHD C-12D 24V
32V2	P8146Z032V2	RELAY STON MY4S 24V V2.01.13
32-1	P8146Z032-1	RELAY MOUNT STON PYF15
33	P8146Z033	FUSE HOLDER
34	P8146Z034	FUSE 3A
35	P8146Z035	WIRING BLOCK 10-POST



# Updated G8144Z/45Z/46Z Cabinet Parts



REF	PART #	DESCRIPTION
301	P8144Z301	HEX BOLT 1/4-20 X 4
302	P8144Z302	TRANSFORMER BRACKET
303	P8144Z303	FLAT WASHER 1/4
304	P8144Z304	HEX NUT 1/4-20
305	P8144Z305	LIMIT SWITCH
306	P8144Z306	CAP SCREW M6-1 X 25
307	P8144Z307	CAP SCREW M6-1 X 10
308	P8144Z308	LIMIT SWITCH BRACKET
309	P8144Z309	SLIDING BLOCK
310	P8144Z310	WELDING CLAMP LEFT
311	P8144Z311	WELDING JAW LEFT
312	P8144Z312	CAP SCREW M6-1 X 12
313	P8144Z313	E-CLIP 4MM
314	P8144Z314	SHAFT
315	P8144Z315	CLAMP LEVER
316	P8144Z316	CAP SCREW M6-1 X 12
317	P8144Z317	SLIDING BLOCK BASE
318	P8144Z318	PHLP HD SCR M6-1 X 16
319	P8144Z319	GRINDER COVER
320	P8144Z320	HEX NUT M6-1
321	P8144Z321	FLAT WASHER 6MM
322	P8144Z322	GRINDING WHEEL 2-1/2"D
323	P8144Z323	FLAT WASHER 6MM
324	P8144Z324	GRINDER MOTOR 1/8HP 220V 1PH
324-1	P8144Z324-1	S CAPACITOR 3M 250V 3/4 X 1-1/4
325	P8144Z325	ON/OFF SWITCH

REF	PART #	DESCRIPTION
326	P8144Z326	PHLP HD SCR M6-1 X 16
327	P8144Z327	PHLP HD SCR M6-1 X 20
328	P8144Z328	WELDING PANEL
329	P8144Z329	CLAMP PRESSURE KNOB
330	P8144Z330	E-CLIP 4MM
331	P8144Z331	CLAMP LEVER
332	P8144Z332	SHAFT
333	P8144Z333	WELDING CLAMP RIGHT
334	P8144Z334	INSULATING PLATE
335	P8144Z335	FLAT WASHER 6MM
336	P8144Z336	CAP SCREW M6-1 X 20
337	P8144Z337	CAP SCREW M6-1 X 20
338	P8144Z338	WELDING JAW RIGHT
339	P8144Z339	CAP SCREW M6-1 X 20
340	P8144Z340	HEX NUT M6-1
341	P8144Z341	FLAT WASHER 6MM
342	P8144Z342	PRESSURE CAM
343	P8144Z343	CAM SHAFT
344	P8144Z344	TENSION SPRING 0.8 X 25MM
345	P8144Z345	PHLP HD SCR 1/4-20 X 1/2
346	P8144Z346	BRACKET
347V2	P8144Z347V2	ANNEALING PUSH BUTTON V2.06.08
348V2	P8144Z348V2	WELDING PUSH BUTTON V2.06.08
349	P8144Z349	TRANSFORMER 1.2KVA 220V (G8144Z)
349	P8145Z349	TRANSFORMER 2KVA 220V (G8145Z)
349	P8146Z349	TRANSFORMER 4.2KVA 220V (G8146Z)



# *grizzly.com*<sup>®</sup>

**TOOL WEBSITE**

Buy Direct and Save with Grizzly<sup>®</sup> – Trusted, Proven and a Great Value!  
~Since 1983~

*Visit Our Website Today For  
Current Specials!*

**ORDER  
24 HOURS A DAY!  
1-800-523-4777**



# *Grizzly* *Industrial, Inc.*®

## MODEL G8144Z/G8145Z/G8146Z VARIABLE SPEED VERTICAL METAL CUTTING BANDSAW OWNER'S MANUAL



COPYRIGHT © JANUARY, 2008 BY GRIZZLY INDUSTRIAL, INC., REVISED JUNE, 2011 (TS)  
**WARNING: NO PORTION OF THIS MANUAL MAY BE REPRODUCED IN ANY SHAPE  
OR FORM WITHOUT THE WRITTEN APPROVAL OF GRIZZLY INDUSTRIAL, INC.**  
(FOR MODELS MANUFACTURED SINCE 6/11) #TS10085 PRINTED IN TAIWAN

 **WARNING!**

**This manual provides critical safety instructions on the proper setup, operation, maintenance, and service of this machine/tool. Save this document, refer to it often, and use it to instruct other operators.**

**Failure to read, understand and follow the instructions in this manual may result in fire or serious personal injury—including amputation, electrocution, or death.**

**The owner of this machine/tool is solely responsible for its safe use. This responsibility includes but is not limited to proper installation in a safe environment, personnel training and usage authorization, proper inspection and maintenance, manual availability and comprehension, application of safety devices, cutting/sanding/grinding tool integrity, and the usage of personal protective equipment.**

**The manufacturer will not be held liable for injury or property damage from negligence, improper training, machine modifications or misuse.**

 **WARNING!**

**Some dust created by power sanding, sawing, grinding, drilling, and other construction activities contains chemicals known to the State of California to cause cancer, birth defects or other reproductive harm. Some examples of these chemicals are:**

- **Lead from lead-based paints.**
- **Crystalline silica from bricks, cement and other masonry products.**
- **Arsenic and chromium from chemically-treated lumber.**

**Your risk from these exposures varies, depending on how often you do this type of work. To reduce your exposure to these chemicals: Work in a well ventilated area, and work with approved safety equipment, such as those dust masks that are specially designed to filter out microscopic particles.**

# Table of Contents

<b>INTRODUCTION</b> .....	<b>2</b>	<b>SECTION 5: ACCESSORIES</b> .....	<b>36</b>
Foreword.....	2	<b>SECTION 6: MAINTENANCE</b> .....	<b>37</b>
Contact Info .....	2	Schedule.....	37
G8144Z Machine Data Sheet .....	3	Cleaning.....	37
G8145Z Machine Data Sheet .....	5	Redressing Rubber Tires.....	37
G8146Z Machine Data Sheet .....	7	Lubrication .....	38
Model G8144Z/G8145Z Basic Identification..	9	<b>SECTION 7: SERVICE</b> .....	<b>39</b>
Model G8146Z Basic Identification.....	10	Troubleshooting .....	39
Control Panel Identification.....	11	V-Belt Pulley Alignment.....	41
<b>SECTION 1: SAFETY</b> .....	<b>12</b>	Tensioning/Replacing V-Belts .....	41
Safety Instructions for Machinery .....	12	Aligning Table To Blade .....	42
Safety Instructions for		Blade Guides/Support.....	43
Metal Cutting Bandsaws.....	14	G8144Z/G8145Z Control Panel &	
<b>SECTION 2: CIRCUIT REQUIREMENTS</b> .....	<b>15</b>	Inverter Wiring Diagram.....	44
220V Operation.....	15	G8144Z/G8145Z Electrical Components.....	45
<b>SECTION 3: SETUP</b> .....	<b>16</b>	G8146Z Electrical &	
Setup Safety .....	16	Control Wiring Diagram .....	46
Items Needed for Setup.....	16	G8146Z Inverter Wiring Diagram.....	47
Unpacking .....	16	G8146Z Electrical Components.....	48
Clean Up.....	17	Motor Wiring Diagram.....	49
Site Considerations.....	17	Welding Station Wiring Diagram.....	50
Mounting to Shop Floor .....	18	<b>SECTION 8: PARTS</b> .....	<b>51</b>
Moving & Placing.....	18	G8144Z Cabinet .....	51
Test Run.....	19	G8144Z Table & Guides .....	52
<b>SECTION 4: OPERATIONS</b> .....	<b>21</b>	G8144Z Drive System .....	53
Operation Safety .....	21	G8145Z Cabinet .....	54
Basic Controls.....	21	G8145Z Table & Guides .....	55
Blade Selection.....	23	G8145Z Drive System .....	56
Blade Breakage .....	26	G8146Z Cabinet .....	57
Blade Care & Break-In.....	26	G8146Z Table & Lower Guides .....	58
Chip Inspection Chart .....	27	G8146Z Motor & Lower Wheel.....	59
Cutting Overview .....	28	G8146Z Guide Post.....	60
Blade Changes .....	28	G8146Z Upper Wheel.....	61
Blade Tensioning.....	29	Welder Station .....	62
Guide Post.....	30	Label Placement .....	64
Adjusting Blade Guides .....	31	<b>WARRANTY AND RETURNS</b> .....	<b>65</b>
Adjusting Table Tilt.....	32		
Blade Welding.....	33		

# INTRODUCTION

---

---

## Foreword

---

---

We are proud to offer the Model G8144Z/G8145Z/G8146Z Variable Speed Vertical Metal Cutting Bandsaw. This machine is part of a growing Grizzly family of fine metalworking machinery. When used according to the guidelines set forth in this manual, you can expect years of trouble-free, enjoyable operation and proof of Grizzly's commitment to customer satisfaction.

The specifications, drawings, and photographs illustrated in this manual represent the Model G8144Z/G8145Z/G8146Z when the manual was prepared. However, owing to Grizzly's policy of continuous improvement, changes may be made at any time with no obligation on the part of Grizzly.

For your convenience, we always keep current Grizzly manuals available on our website at **[www.grizzly.com](http://www.grizzly.com)**. Any updates to your machine will be reflected in these manuals as soon as they are complete. Visit our site often to check for the latest updates to this manual!

## Contact Info

---

---

If you have any comments regarding this manual, please write to us at the address below:

Grizzly Industrial, Inc.  
c/o Technical Documentation Manager  
P.O. Box 2069  
Bellingham, WA 98227-2069  
Email: [manuals@grizzly.com](mailto:manuals@grizzly.com)

We stand behind our machines. If you have any service questions or parts requests, please call or write us at the location listed below.

Grizzly Industrial, Inc.  
1203 Lycoming Mall Circle  
Muncy, PA 17756  
Phone: (570) 546-9663  
Fax: (800) 438-5901  
E-Mail: [techsupport@grizzly.com](mailto:techsupport@grizzly.com)  
Web Site: <http://www.grizzly.com>





# MACHINE DATA SHEET

Customer Service #: (570) 546-9663 · To Order Call: (800) 523-4777 · Fax #: (800) 438-5901

## MODEL G8144Z 12" 1 HP VS VERTICAL METAL-CUTTING BANDSAW WITH INVERTER

### Product Dimensions:

Weight..... 370 lbs.  
 Width (side-to-side) x Depth (front-to-back) x Height..... 34 x 21-1/4 x 59-7/8 in.  
 Footprint (Length x Width)..... 28-5/8 x 15 in.

### Shipping Dimensions:

Type..... Cardboard Box on Wood Skids  
 Content..... Machine  
 Weight..... 566 lbs.  
 Length x Width x Height..... 23 x 32 x 68 in.  
 Must Ship Upright..... Yes

### Electrical:

Power Requirement..... 220V, Single-Phase, 60 Hz  
 Prewired Voltage..... 220V  
 Full-Load Current Rating..... 3.9A  
 Minimum Circuit Size..... 15A  
 Connection Type..... Cord & Plug  
 Power Cord Included..... Yes  
 Power Cord Length..... 6-1/2 ft.  
 Power Cord Gauge..... 14 AWG  
 Plug Included..... No  
 Recommended Plug Type..... 6-15  
 Switch Type..... ON/OFF Push Button Switch  
 Inverter (VFD) Type..... Rhymebus RM5G-200V  
 Inverter (VFD) Size..... 1 HP

### Motors:

#### Grinder

Horsepower..... 1/8 HP  
 Phase..... Single-Phase  
 Amps..... 0.6A  
 Speed..... 3450 RPM  
 Type..... ODP Permanent-Split Capacitor  
 Power Transfer ..... Direct Drive  
 Bearings..... Sealed & Permanently Lubricated  
 Centrifugal Switch/Contacts Type..... N/A

#### Main

Horsepower..... 1 HP  
 Phase..... 3-Phase  
 Amps..... 3.3A  
 Speed..... 1725 RPM  
 Type..... TEFC Induction  
 Power Transfer ..... Belt Drive  
 Bearings..... Shielded & Permanently Lubricated  
 Centrifugal Switch/Contacts Type..... N/A



**Main Specifications:**

**Main Specifications**

Bandsaw Size.....	12 in.
Max Cutting Width (Left of Blade).....	12-3/16 in.
Max Cutting Height.....	5-1/8 in.
Blade Speeds.....	104 – 1300 FPM

**Blade Information**

Standard Blade Length.....	97 in.
Blade Length Range.....	94-1/4 – 98-1/4 in.
Blade Width Range.....	1/8 – 3/8 in.
Blade Guides.....	Tungsten Steel

**Table Information**

Table Length.....	22-1/8 in.
Table Width.....	18-1/8 in.
Table Thickness.....	1-5/8 in.
Table Tilt - Left/Right.....	Left 15, Right 45 deg.
Floor-to-Table Height.....	34-5/8 in.
Includes Fence.....	No

**Blade Welding Station Information**

Blade Width Range (Bi-Metal).....	1/8 – 3/8 in.
Blade Thickness.....	0.025 in.
Welding Power.....	1.2 KVA
Grinder Wheel Size.....	1/4 x 3/4 x 2-1/2 in.
Grinder Wheel Grit.....	#60
Grinder Wheel Speed.....	3450 RPM

**Construction Materials**

Table.....	Precision-Ground Cast Iron
Base/Stand.....	Pre-Formed Steel
Body/Frame.....	Cast Iron
Wheels.....	Fully-Balanced Cast Iron
Tires.....	Rubber
Wheel Covers.....	Pre-Formed Steel
Paint Type/Finish.....	Urethane

**Other Related Information**

Wheel Diameter.....	12 in.
Wheel Width.....	1-1/8 in.
Tire Width.....	1/2 in.
Compatible Mobile Base.....	D2058A

**Other Specifications:**

Country of Origin .....	Taiwan
Warranty .....	1 Year
Approximate Assembly & Setup Time .....	1 Hour
Serial Number Location .....	ID Label on Upper Wheel Cover
ISO 9001 Factory .....	No
Certified by a Nationally Recognized Testing Laboratory (NRTL) .....	No

**Features:**

- Station for Joining Blade Ends
- Includes Cut-Off Blades, Electric Welder w/Clamp, Annealer and Grinder
- Variable Cutting Speeds w/Digital Read-Out
- Lower Wheel Cleaning Brush
- Work Light





# MACHINE DATA SHEET

Customer Service #: (570) 546-9663 · To Order Call: (800) 523-4777 · Fax #: (800) 438-5901

## MODEL G8145Z 14-1/8" 1-1/2 HP VS VERTICAL METAL-CUTTING BANDSAW WITH INVERTER

### Product Dimensions:

Weight..... 420 lbs.  
 Width (side-to-side) x Depth (front-to-back) x Height..... 37 x 15-1/8 x 62-5/8 in.  
 Footprint (Length x Width)..... 28 x 16-1/2 in.

### Shipping Dimensions:

Type..... Cardboard Box on Wood Skids  
 Content..... Machine  
 Weight..... 432 lbs.  
 Length x Width x Height..... 24 x 36 x 72 in.  
 Must Ship Upright..... Yes

### Electrical:

Power Requirement..... 220V, Single-Phase, 60 Hz  
 Prewired Voltage..... 220V  
 Full-Load Current Rating..... 5.7A  
 Minimum Circuit Size..... 15A  
 Connection Type..... Cord & Plug  
 Power Cord Included..... Yes  
 Power Cord Length..... 6-1/2 ft.  
 Power Cord Gauge..... 14 AWG  
 Plug Included..... No  
 Recommended Plug Type..... 6-15  
 Switch Type..... ON/OFF Push Button Switch  
 Inverter (VFD) Type..... Rhymebus RM5G-200V  
 Inverter (VFD) Size..... 1.5 HP

### Motors:

#### Grinder

Horsepower..... 1/8 HP  
 Phase..... Single-Phase  
 Amps..... 0.6A  
 Speed..... 3450 RPM  
 Type..... ODP Permanent-Split Capacitor  
 Power Transfer..... Direct Drive  
 Bearings..... Sealed & Permanently Lubricated  
 Centrifugal Switch/Contacts Type..... N/A

#### Main

Horsepower..... 1.5 HP  
 Phase..... 3-Phase  
 Amps..... 5.1A  
 Speed..... 1725 RPM  
 Type..... TEFC Induction  
 Power Transfer..... Belt Drive  
 Bearings..... Shielded & Permanently Lubricated  
 Centrifugal Switch/Contacts Type..... N/A



**Main Specifications:**

**Main Specifications**

Bandsaw Size.....	14 in.
Max Cutting Width (Left of Blade).....	14-3/16 in.
Max Cutting Height.....	7-1/2 in.
Blade Speeds.....	108 – 1800 FPM

**Blade Information**

Standard Blade Length.....	108 in.
Blade Length Range.....	105 – 110 in.
Blade Width Range.....	1/8 – 1/2 in.
Blade Guides.....	Tungsten Steel

**Table Information**

Table Length.....	21-5/16 in.
Table Width.....	19-3/4 in.
Table Thickness.....	2 in.
Table Tilt - Left/Right.....	Left 15, Right 45 deg.
Floor-to-Table Height.....	35 in.
Includes Fence.....	No

**Blade Welding Station Information**

Blade Width Range (Bi-Metal).....	1/8 – 1/2 in.
Blade Thickness.....	0.025 in.
Welding Power.....	2.0 KVA
Grinder Wheel Size.....	1/4 x 3/4 x 2-1/2 in.
Grinder Wheel Grit.....	#60
Grinder Wheel Speed.....	3450 RPM

**Construction Materials**

Table.....	Precision-Ground Cast Iron
Base/Stand.....	Pre-Formed Steel
Body/Frame.....	Cast Iron
Wheels.....	Fully-Balanced Cast Iron
Tires.....	Rubber
Wheel Covers.....	Pre-Formed Steel
Paint Type/Finish.....	Urethane

**Other Related Information**

Wheel Diameter.....	14 in.
Wheel Width.....	1-1/8 in.
Tire Width.....	9/16 in.
Compatible Mobile Base.....	D2058A

**Other Specifications:**

Country of Origin .....	Taiwan
Warranty .....	1 Year
Approximate Assembly & Setup Time .....	1 Hour
Serial Number Location .....	ID Label on Upper Wheel Cover
ISO 9001 Factory .....	No
Certified by a Nationally Recognized Testing Laboratory (NRTL) .....	No

**Features:**

- Station for Joining Blade Ends
- Includes Cut-Off Blades, Electric Welder w/Clamp, Annealer and Grinder
- Variable Cutting Speeds w/Digital Read-Out
- Lower Wheel Cleaning Brush
- Work Light





# MACHINE DATA SHEET

Customer Service #: (570) 546-9663 · To Order Call: (800) 523-4777 · Fax #: (800) 438-5901

## MODEL G8146Z 15-3/4" 2 HP VS VERTICAL METAL-CUTTING BANDSAW WITH INVERTER

### Product Dimensions:

Weight..... 694 lbs.  
 Width (side-to-side) x Depth (front-to-back) x Height..... 36-3/8 x 19-1/8 x 71-1/8 in.  
 Footprint (Length x Width)..... 40-1/8 x 27-9/16 in.

### Shipping Dimensions:

Type..... Cardboard Box on Wood Skids  
 Content..... Machine  
 Weight..... 694 lbs.  
 Length x Width x Height..... 41 x 31 x 82 in.  
 Must Ship Upright..... Yes

### Electrical:

Power Requirement..... 220V, Single-Phase, 60 Hz  
 Prewired Voltage..... 220V  
 Full-Load Current Rating..... 7.2A  
 Minimum Circuit Size..... 15A  
 Connection Type..... Cord & Plug  
 Power Cord Included..... Yes  
 Power Cord Length..... 6-1/2 ft.  
 Power Cord Gauge..... 14 AWG  
 Plug Included..... No  
 Recommended Plug Type..... 6-15  
 Switch Type..... Control Panel w/Magnetic Switch Protection & Lockout Key  
 Inverter (VFD) Type..... Rhymebus RM5G-200V  
 Inverter (VFD) Size..... 2 HP

### Motors:

#### Main

Horsepower..... 2 HP  
 Phase..... 3-Phase  
 Amps..... 6.6A  
 Speed..... 1725 RPM  
 Type..... TEFC Induction  
 Power Transfer ..... Belt Drive  
 Bearings..... Shielded & Permanently Lubricated  
 Centrifugal Switch/Contacts Type..... N/A

#### Grinder

Horsepower..... 1/8 HP  
 Phase..... Single-Phase  
 Amps..... 0.6A  
 Speed..... 3450 RPM  
 Type..... ODP Permanent-Split Capacitor  
 Power Transfer ..... Direct Drive  
 Bearings..... Sealed & Permanently Lubricated  
 Centrifugal Switch/Contacts Type..... N/A



**Main Specifications:**

**Main Specifications**

Bandsaw Size.....	16 in.
Max Cutting Width (Left of Blade).....	15-3/4 in.
Max Cutting Height.....	10-1/4 in.
Blade Speeds.....	105 – 2100 FPM

**Blade Information**

Standard Blade Length.....	134 in.
Blade Length Range.....	133 – 136 in.
Blade Width Range.....	1/8 – 3/4 in.
Blade Guides.....	Tungsten Steel

**Table Information**

Table Length.....	23-5/8 in.
Table Width.....	21-11/16 in.
Table Thickness.....	2 in.
Table Tilt - Left/Right.....	Left 15, Right 45 deg.
Floor-to-Table Height.....	38 in.
Includes Fence.....	No

**Blade Welding Station Information**

Blade Width Range (Bi-Metal).....	1/8 – 5/8 in.
Blade Thickness.....	0.025 – 0.035 in.
Welding Power.....	4.2 KVA
Grinder Wheel Size.....	1/4 x 3/4 x 2-1/2 in.
Grinder Wheel Grit.....	#60
Grinder Wheel Speed.....	3450 RPM

**Construction Materials**

Table.....	Precision-Ground Cast Iron
Base/Stand.....	Pre-Formed Steel
Body/Frame.....	Cast Iron
Wheels.....	Fully-Balanced Cast Iron
Tires.....	Rubber
Wheel Covers.....	Pre-Formed Steel
Paint Type/Finish.....	Urethane

**Other Related Information**

Wheel Diameter.....	16 in.
Wheel Width.....	1-1/8 in.
Tire Width.....	7/8 in.
Compatible Mobile Base.....	D2058A

**Other Specifications:**

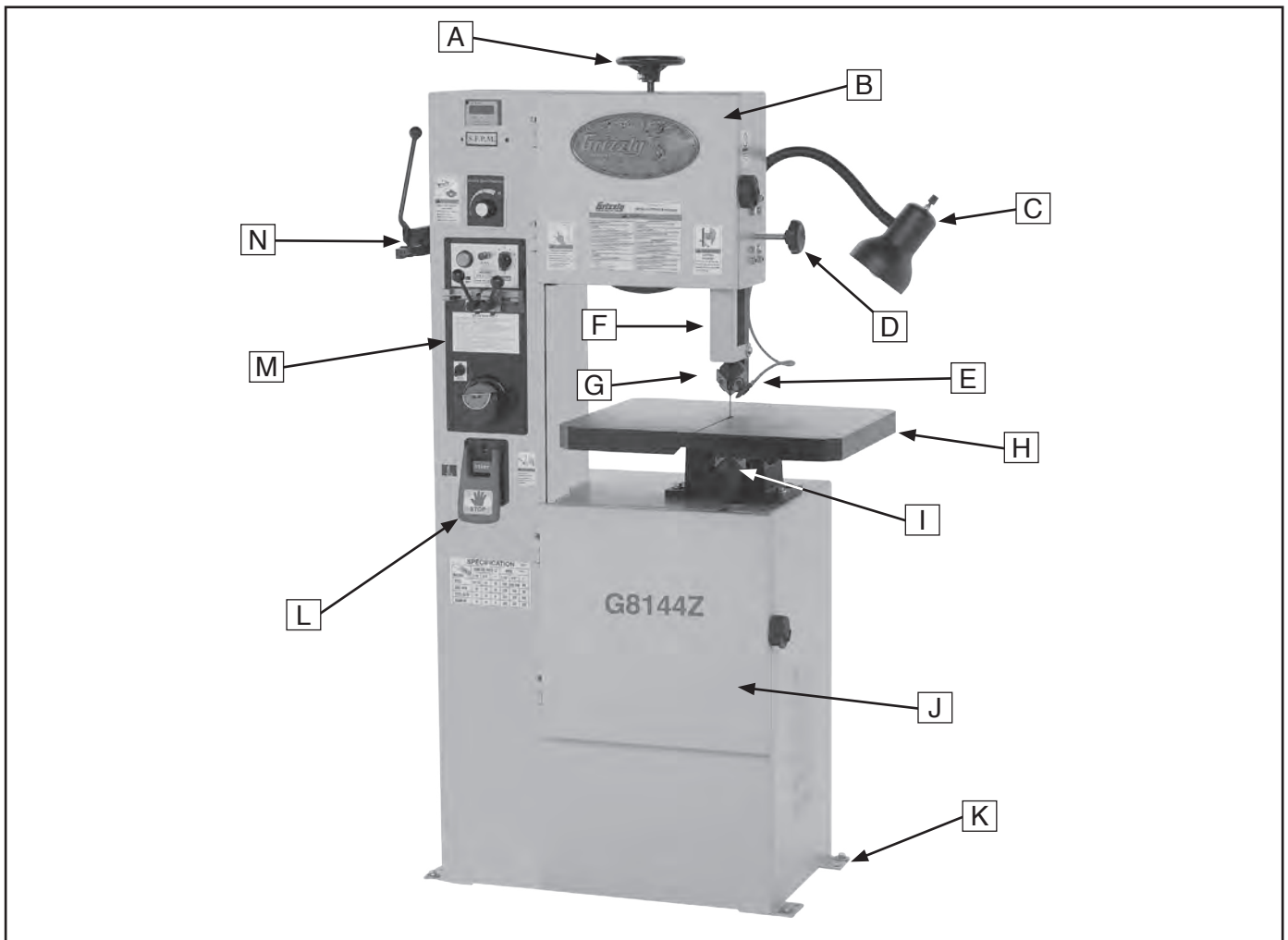
Country of Origin .....	Taiwan
Warranty .....	1 Year
Approximate Assembly & Setup Time .....	1 Hour
Serial Number Location .....	ID Label on Upper Wheel Cover
ISO 9001 Factory .....	No
Certified by a Nationally Recognized Testing Laboratory (NRTL) .....	No

**Features:**

- Station for Joining Blade Ends
- Includes Cut-Off Blades, Electric Welder w/Clamp, Annealer and Grinder
- Variable Cutting Speeds w/Digital Read-Out
- Lower Wheel Cleaning Brush
- Work Light



# Model G8144Z/G8145Z Basic Identification

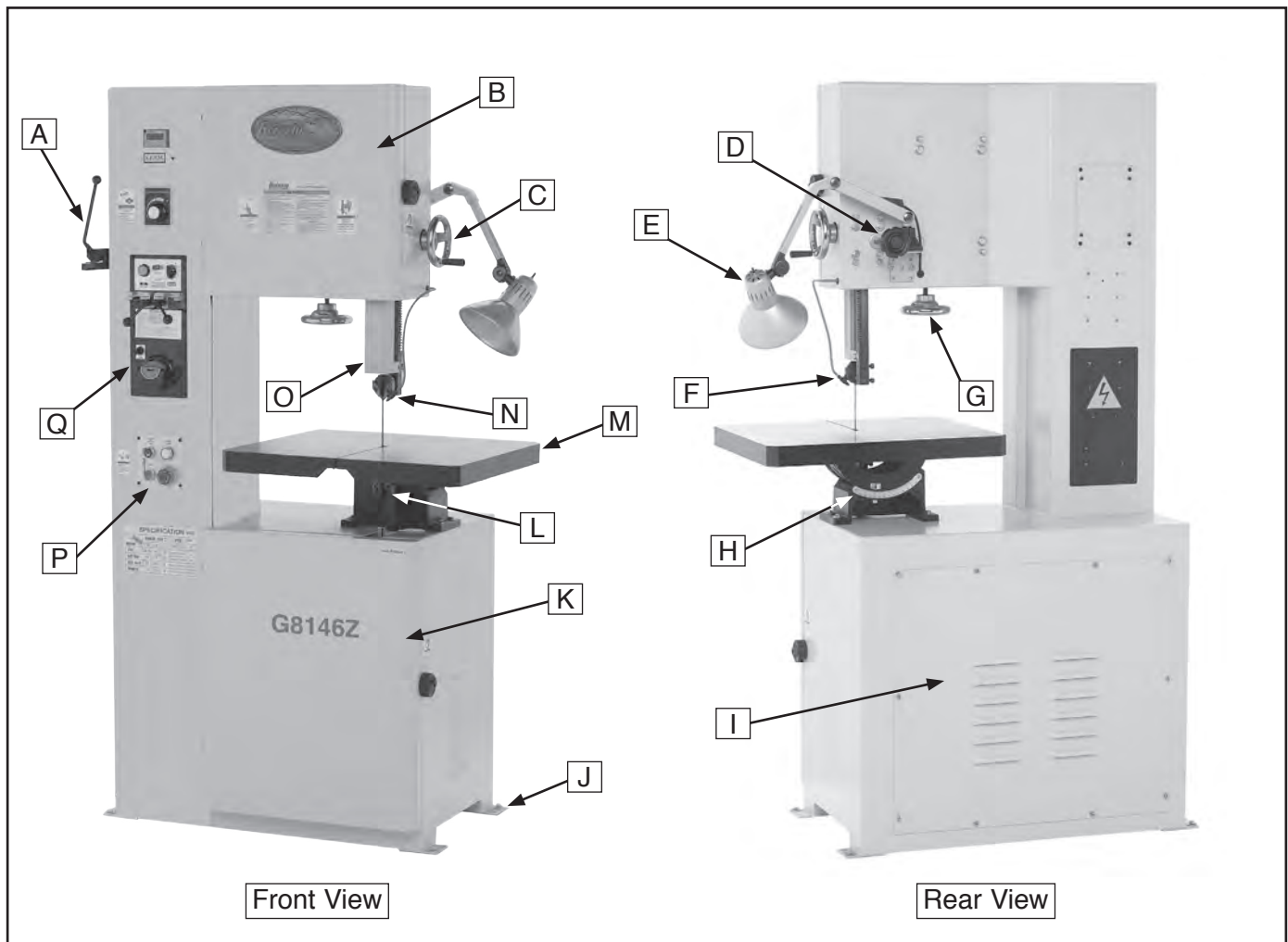


**Figure 1.** Model G8144Z/G8145Z basic identification.

- |                                      |                                      |
|--------------------------------------|--------------------------------------|
| <b>A.</b> Blade Tensioning Handwheel | <b>H.</b> Table                      |
| <b>B.</b> Upper Wheel Door           | <b>I.</b> Lower Blade Guide Assembly |
| <b>C.</b> Work Light (220V)          | <b>J.</b> Lower Wheel Door           |
| <b>D.</b> Blade Post Lock Knob       | <b>K.</b> Machine Mounting Flange    |
| <b>E.</b> Air Hose & Jet             | <b>L.</b> Bandsaw Start/Stop Switch  |
| <b>F.</b> Blade Guard                | <b>M.</b> Blade Welding Station      |
| <b>G.</b> Upper Blade Guide Assembly | <b>N.</b> Blade Shear                |



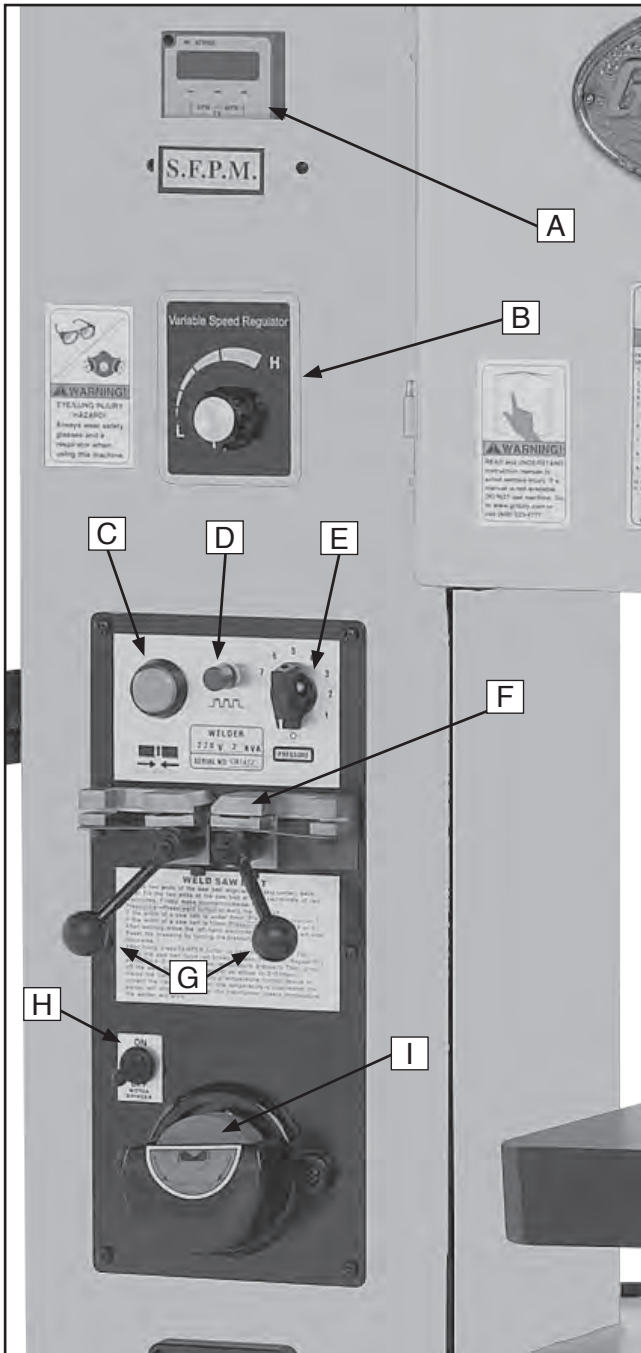
# Model G8146Z Basic Identification



- |  |                                       |
|--|---------------------------------------|
| <b>A.</b> Blade Shear                    | <b>J.</b> Machine Mounting Flange     |
| <b>B.</b> Upper Wheel Door               | <b>K.</b> Lower Wheel Door            |
| <b>C.</b> Guide Post Elevation Handwheel | <b>L.</b> Lower Blade Guide Assembly  |
| <b>D.</b> Guide Post Lock Knob           | <b>M.</b> Table                       |
| <b>E.</b> Work Light (220V)              | <b>N.</b> Upper Blade Guide Assembly  |
| <b>F.</b> Air Hose & Jet                 | <b>O.</b> Blade Post                  |
| <b>G.</b> Blade Tension Handwheel        | <b>P.</b> Bandsaw Power Control Panel |
| <b>H.</b> Table Tilt Scale               | <b>Q.</b> Blade Welding Station       |
| <b>I.</b> Motor Access Panel             |                                       |



# Control Panel Identification



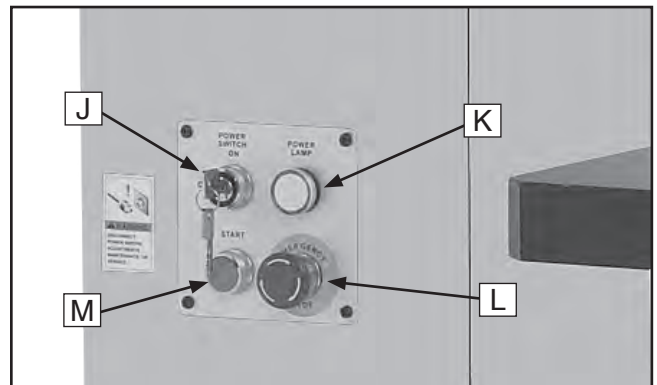
**Figure 3.** Control panel identification.

- A. Digital Speed Display (FPM)
- B. Variable Speed Control
- C. Welding ON Button
- D. Annealing ON Button
- E. Clamping Pressure Dial
- F. Welder Jaws
- G. Welding Jaw Lock Levers
- H. Grinding Wheel ON/OFF Switch
- I. Grinding Wheel

G8144Z/G8145Z/G8146Z  
(Manufactured Since 6/11)



**Figure 4.** Model G8144Z/G8145Z power switch.



**Figure 5.** Model G8146Z power control panel.

## Model G8146Z only:

- J. Power Switch & Key
- K. Power Lamp
- L. Emergency Stop Button
- M. Bandsaw Start Button



# SECTION 1: SAFETY

## WARNING

### For Your Own Safety, Read Instruction Manual Before Operating this Machine

The purpose of safety symbols is to attract your attention to possible hazardous conditions. This manual uses a series of symbols and signal words intended to convey the level of importance of the safety messages. The progression of symbols is described below. Remember that safety messages by themselves do not eliminate danger and are not a substitute for proper accident prevention measures.



Indicates an imminently hazardous situation which, if not avoided, **WILL** result in death or serious injury.



Indicates a potentially hazardous situation which, if not avoided, **COULD** result in death or serious injury.



Indicates a potentially hazardous situation which, if not avoided, **MAY** result in minor or moderate injury. It may also be used to alert against unsafe practices.

**NOTICE**

This symbol is used to alert the user to useful information about proper operation of the machine.

## WARNING

### Safety Instructions for Machinery

**OWNER'S MANUAL.** Read and understand this owner's manual **BEFORE** using machine. Untrained users can be seriously hurt.

**EYE PROTECTION.** Always wear ANSI-approved safety glasses or a face shield when operating or observing machinery. to reduce the risk of eye injury or blindness from flying particles Everyday eyeglasses are not approved safety glasses.

**HAZARDOUS DUST.** Dust created while using machinery may cause cancer, birth defects, or long-term respiratory damage. Be aware of dust hazards associated with each workpiece material, and always wear a NIOSH-approved respirator to reduce your risk.

**WEARING PROPER APPAREL.** Do not wear clothing, apparel, or jewelry that can become entangled in moving parts. Always tie back or cover long hair. Wear non-slip footwear to avoid accidental slips which could cause a loss of workpiece control.

**HEARING PROTECTION.** Always wear hearing protection when operating or observing loud machinery. Extended exposure to this noise without hearing protection can cause permanent hearing loss.

**MENTAL ALERTNESS.** Be mentally alert when running machinery. Never operate under the influence of drugs or alcohol, when tired, or when distracted.



# WARNING

## Safety Instructions for Machinery

**DISCONNECTING POWER SUPPLY.** Always disconnect machine from power supply before servicing, adjusting, or changing cutting tools (bits, blades, cutters, etc.). Make sure switch is in OFF position before reconnecting to avoid an unexpected or unintentional start.

**INTENDED USE.** Only use the machine for its intended purpose and only use recommended accessories. Never stand on machine, modify it for an alternative use, or outfit it with non-approved accessories.

**STABLE MACHINE.** Unexpected movement during operations greatly increases the risk of injury and loss of control. Verify machines are stable/secure and mobile bases (if used) are locked before starting.

**FORCING MACHINERY.** Do not force machine. It will do the job safer and better at the rate for which it was designed.

**GUARDS & COVERS.** Guards and covers can protect you from accidental contact with moving parts or flying debris. Make sure they are properly installed, undamaged, and working correctly before using machine.

**REMOVING TOOLS.** Never leave adjustment tools, chuck keys, wrenches, etc. in or on machine—especially near moving parts. Verify removal before starting!

**AWKWARD POSITIONS.** Keep proper footing and balance at all times when operating machine. Do not overreach! Avoid awkward hand positions that make workpiece control difficult or increase the risk of accidental injury.

**DANGEROUS ENVIRONMENTS.** Do not use machinery in wet locations, cluttered areas, around flammables, or in poorly-lit areas. Keep work area clean, dry, and well lighted to minimize risk of injury.

**APPROVED OPERATION.** Untrained operators can be seriously hurt by machinery. Only allow trained or properly supervised people to use machine. When machine is not being used, disconnect power, remove switch keys, or lock-out machine to prevent unauthorized use—especially around children. Make workshop kid proof!

**CHILDREN & BYSTANDERS.** Keep children and bystanders a safe distance away from work area. Stop using machine if children or bystanders become a distraction.

**FEED DIRECTION.** Unless otherwise noted, feed work against the rotation of blades or cutters. Feeding in the same direction of rotation may pull your hand into the cut.

**SECURING WORKPIECE.** When required, use clamps or vises to secure workpiece. A secured workpiece protects hands and frees both of them to operate the machine.

**UNATTENDED OPERATION.** Never leave machine running while unattended. Turn machine **OFF** and ensure all moving parts completely stop before walking away.

**MAINTENANCE & INSPECTION.** A machine that is not properly maintained may operate unpredictably. Follow all maintenance instructions and lubrication schedules to keep machine in good working condition. Regularly inspect machine for loose bolts, alignment of critical parts, binding, or any other conditions that may affect safe operation. Always repair or replace damaged or mis-adjusted parts before operating machine.

**EXPERIENCING DIFFICULTIES.** If at any time you are experiencing difficulties performing the intended operation, stop using the machine! Contact our Technical Support Department at (570) 546-9663.



## **WARNING**

# Safety Instructions for Metal Cutting Bandsaws

- 1. BLADE CONDITION.** Do not operate with dull, cracked or badly worn blade that can break during operation or decrease the performance of the bandsaw. Inspect blades for cracks and missing teeth before each use.
- 2. BLADE REPLACEMENT.** Wear gloves to protect hands and safety glasses to protect eyes when replacing the blade. When replacing blades, make sure teeth face forward and down toward the table in the direction of blade travel.
- 3. WORKPIECE HANDLING.** Your hands can be drawn into the blade during operation if the workpiece moves unexpectedly. Always keep your hands a safe distance away from the moving blade.
- 4. FIRE HAZARD.** Use **EXTREME CAUTION** if cutting magnesium. Using the wrong cutting fluid will lead to chip fire and possible explosion.
- 5. WELDING AND GRINDING SAFETY.** The welding station represents a serious hazard. **DO NOT** touch any metal parts of the blade, welder, or machine when activating the welder. Keep your hands a safe distance away from the grinding wheel when in use.
- 6. HOT SURFACES.** Be aware that touching hot workpieces or chips after welding, grinding, or cutting can cause burns.
- 7. CUTTING FLUID SAFETY.** Cutting fluids are poisonous. Always follow manufacturer's cutting-fluid safety instructions. Pay particular attention to contact, contamination, inhalation, storage and disposal warnings. Spilled cutting fluid invites slipping hazards.
- 8. ENTANGLEMENT HAZARDS.** Always keep the blade guard correctly positioned and wheel doors closed and secured when bandsaw is in operation. Loose clothing, jewelry, long hair and work gloves can be drawn into working parts.
- 9. MAINTENANCE/SERVICE.** All inspections, adjustments, and maintenance are to be done with the power **OFF** and the plug pulled from the outlet. Wait for all moving parts to come to a complete stop.
- 10. UNSTABLE WORKPIECES.** Workpieces that cannot be supported or stabilized without a vise or jig should not be cut on a vertical metal-cutting bandsaw, because they can unexpectedly move while cutting and draw the operator's hands into the blade causing serious personal injury. Examples are chains, cables, round or oblong-shaped workpieces, workpieces with internal or built-in moving or rotations parts, etc.
- 11. EXPERIENCING DIFFICULTY.** If at any time you are experiencing difficulties performing the intended operation, stop using the machine! Contact our Technical Support Department at (570) 546-9663.

## **CAUTION**

No list of safety guidelines can be complete. Every shop environment is different. Always consider safety first, as it applies to your individual working conditions. Use this and other machinery with caution and respect. Failure to do so could result in serious personal injury, damage to equipment, or poor work results.

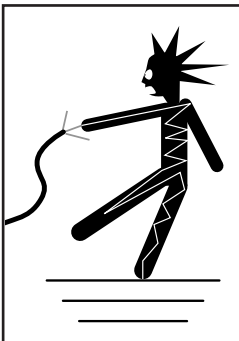


# SECTION 2: CIRCUIT REQUIREMENTS

## 220V Operation

### **!WARNING**

Serious personal injury could occur if you connect the machine to power before completing the setup process. **DO NOT** connect the machine to the power until instructed later in this manual.



### **!WARNING**

Electrocution or fire could result if machine is not grounded and installed in compliance with electrical codes. Compliance **MUST** be verified by a qualified electrician!

### Full Load Amperage Draw

G8144Z Motor Draw at 220V .....	5 Amps
G8145Z Motor Draw at 220V .....	6 Amps
G8146Z Motor Draw at 220V .....	7 Amps

### Circuit Requirements

You **MUST** connect your machine to a grounded circuit that is rated for the amperage given below. Never replace a circuit breaker on an existing circuit with one of higher amperage without consulting a qualified electrician to ensure compliance with wiring codes. **If you are unsure about the wiring codes in your area or you plan to connect your machine to a shared circuit, consult a qualified electrician.**

Minimum 220V Circuit (All Models) ..... 15 Amps

### Power Connection Device

The type of plug required to connect your machine to power depends on the type of service you currently have or plan to install. We recommend using the plug shown in **Figure 6**.

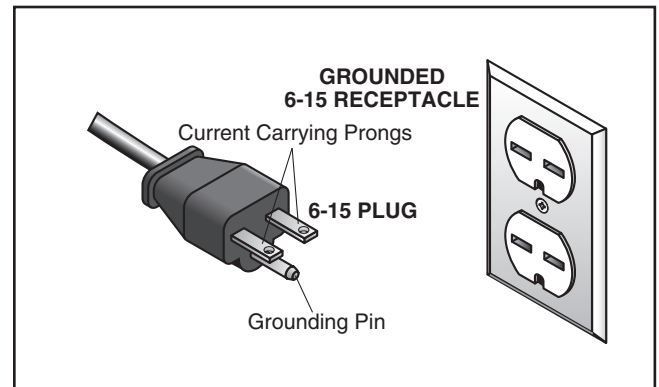


Figure 6. NEMA 6-15 plug and receptacle.

### Extension Cords

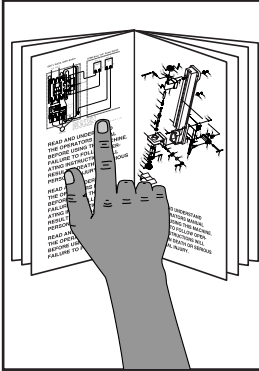
Using extension cords may reduce the life of the motor. Instead, place the machine near a power source. If you must use an extension cord:

- Use at least a 14 gauge cord that does not exceed 50 feet in length!
- The extension cord must also have a ground wire and plug pin.
- A qualified electrician **MUST** size cords over 50 feet long to prevent motor damage.

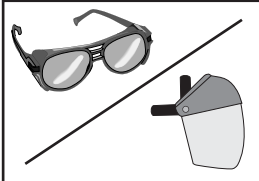


# SECTION 3: SETUP

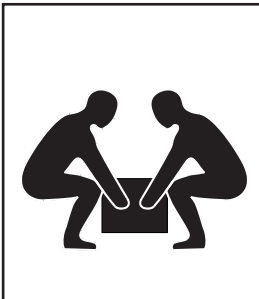
## Setup Safety



**!WARNING**  
This machine presents serious injury hazards to untrained users. Read through this entire manual to become familiar with the controls and operations before starting the machine!



**!WARNING**  
Wear safety glasses or a face shield during the entire setup process!



**!WARNING**  
This machine and its components are very heavy. Get lifting help and use power lifting equipment such as a forklift to move heavy items.

## Items Needed for Setup

The following items are needed to complete the setup process, but are not included with your machine:

Description	Qty
• Assistants .....	2
• Safety Glasses (for each person) .....	1
• Lifting Straps (rated for 1000 lbs.) .....	As Needed
• Forklift (rated for 1000 lbs.) .....	1
• Floor Mounting Hardware.....	As Needed

## Unpacking


Your machine was carefully packaged for safe transportation. Remove the packaging materials from around your machine and inspect it. If you discover the machine is damaged, *please immediately call Customer Service at (570) 546-9663 for advice.*

Save the containers and all packing materials for possible inspection by the carrier or its agent. *Otherwise, filing a freight claim can be difficult.*

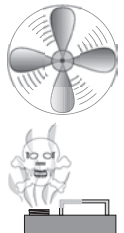


# Clean Up

The unpainted surfaces are coated with a waxy oil to prevent corrosion during shipment. Remove this protective coating with a solvent cleaner or citrus-based degreaser such as Grizzly's G7895 Citrus Degreaser. To clean thoroughly, some parts must be removed. **For optimum performance from your machine, clean all moving parts or sliding contact surfaces.** Avoid chlorine-based solvents, such as acetone or brake parts cleaner that may damage painted surfaces. Always follow the manufacturer's instructions when using any type of cleaning product.



**! WARNING**  
Gasoline and petroleum products have low flash points and can explode or cause fire if used to clean machinery. **DO NOT** use these products to clean the machinery.



**! CAUTION**  
Many cleaning solvents are toxic if inhaled. Minimize your risk by only using these products in a well ventilated area.

## G2544—Solvent Cleaner & Degreaser

A great product for removing the waxy shipping grease from your machine during clean up.

Call  
**1-800-523-4777**  
To Order



**Figure 7.** Cleaner/degreaser available from Grizzly.

G8144Z/G8145Z/G8146Z  
(Manufactured Since 6/11)

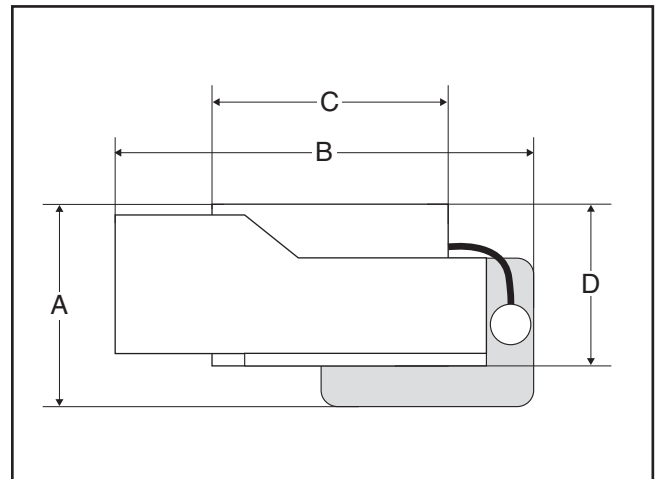
# Site Considerations

## Floor Load

Refer to the **Machine Data Sheet** (starting on **Page 3**) for the weight and footprint specifications of your machine. Some floors may require additional reinforcement to support both the machine and operator.

## Placement Location

Consider existing and anticipated needs, size of material to be processed through each machine, and space for auxiliary stands, work tables or other machinery when establishing a location for your new machine. See Figures 8–9 for the minimum working clearances.



**Figure 8.** Minimum horizontal working clearances (top view).

	A	B	C	D
<b>G8144Z</b>	21 <sup>1</sup> / <sub>4</sub> "	33 <sup>7</sup> / <sub>16</sub> "	15"	28 <sup>5</sup> / <sub>16</sub> "
<b>G8145Z</b>	15 <sup>1</sup> / <sub>8</sub> "	37"	16 <sup>1</sup> / <sub>2</sub> "	28"
<b>G8146Z</b>	19 <sup>1</sup> / <sub>8</sub> "	36 <sup>3</sup> / <sub>8</sub> "	27 <sup>9</sup> / <sub>16</sub> "	40 <sup>1</sup> / <sub>8</sub> "

**Figure 9.** Minimum working clearance dimensions.



# Mounting to Shop Floor

The bandsaw center of gravity is above the middle of the machine. Although not required, we strongly recommend that you mount your new machine to the floor to prevent tipping. Because this is an optional step and floor materials may vary, floor mounting hardware is not included.

## Bolting to Concrete Floors

Anchor studs and lag bolts (Figure 10) are two popular methods for anchoring an object to a concrete floor. We suggest you research the many options and methods for mounting your machine and choose the best that fits your specific application.

### NOTICE

Anchor studs are stronger and more permanent alternatives to lag bolts; however, they will stick out of the floor, which may cause a tripping hazard if you decide to move your machine.

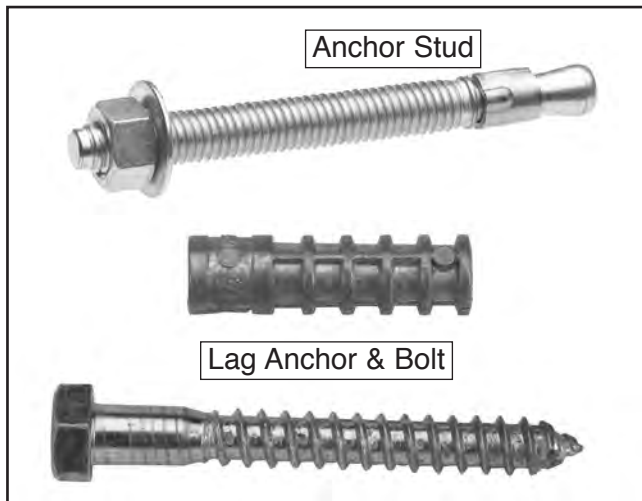
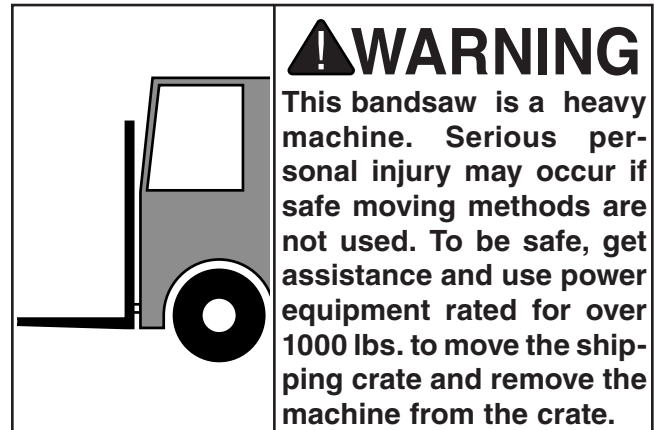


Figure 10. Typical fasteners for mounting to concrete floors.

### NOTICE

We strongly recommend securing your machine to the floor if it is hardwired to the power source. Consult with your electrician to ensure compliance with local codes.

# Moving & Placing



To lift and move the bandsaw:

1. Position lifting straps under the head of the bandsaw and on the forklift forks, as shown in Figure 11.



Figure 11. Lifting straps positioned on bandsaw and forklift forks.

### WARNING

Only use lifting straps and power lifting equipment rated for at least 1000 lbs., and in good working condition. If the bandsaw should fall or tip over while moving it, serious personal injury and property damage could result.



2. Unbolt the bandsaw from the pallet.
3. With two assistants to steady the bandsaw, slowly lift it just enough to clear the pallet and floor obstacles, then move it to the prepared location.
4. Use shims between the machine mounting flanges and the floor to level the bandsaw.

**Note:** *Tighten the mounting fasteners evenly to avoid warping or cracking the cast iron base.*

## Test Run

---



---

Once the bandsaw is in place, test run your machine to make sure it runs properly and is ready for regular operation. The test run consists of verifying the following: 1) The bandsaw motor powers up and runs correctly, and 2) the stop button safety feature works correctly.

If, during the test run, you cannot easily locate the source of an unusual noise or vibration, stop using the machine immediately, then review **Troubleshooting on Page 39**.

If you cannot find a remedy, contact our Tech Support at (570) 546-9663 for assistance.

### To test run the bandsaw:

1. Read and follow the safety instructions at the beginning of the manual, and make sure the machine is setup properly.
2. Clear all tools and objects used during setup away from the machine.
3. Make sure the blade is properly tensioned and the blade guides are positioned correctly (refer to **Blade Tensioning on Page 29**, and **Adjusting Blade Guides on Page 31** for detailed instructions).
4. Connect the machine to the power source.

### 5. Model G8146Z only:

- a. Place the key in the Power Switch and turn it to the ON position—the Power Lamp should light.
- b. Push the Emergency Stop button in, then twist it clockwise so it pops out. When the Emergency Stop button pops out, the switch is reset and ready for operation.
- c. Push the Start button to turn the machine **ON**.

### 6. Models G8144Z & G8145Z only:

- Push the Start button in to turn the machine **ON**.
7. Verify that the machine is operating correctly.
    - When operating correctly, the machine runs smoothly with little or no vibration or rubbing noises.
    - Investigate and correct strange or unusual noises or vibrations before operating the machine further. Always disconnect the machine from power when investigating or correcting potential problems.

### 8. Verify that the motor is running in the correct direction.

- When the motor is running in the correct direction, the blade will be moving down into the table.
- If the motor is NOT running in the correct direction, stop the machine, disconnect the machine from power, and switch any two incoming power leads inside the motor wiring junction box (refer to the **Model G8144Z/G8145Z Control Panel & Inverter Wiring Diagram on Page 44**, or the **Model G8146Z Inverter Wiring Diagram on Page 47** for detailed illustrations).

*Continued on next page* 



## 9. Model G8146Z only:

- a. Press the Emergency Stop button to stop the machine.
- b. WITHOUT resetting the switch, press the Start button. The machine should not start.

—If the machine does not start, the Emergency Stop button safety feature is working correctly.

—If the machine does start (with the stop button pushed in), immediately disconnect power to the machine. The Emergency Stop button safety feature is not working correctly. This safety feature must work properly before proceeding with regular operations. Call Tech Support for help.

- c. Reset the Emergency Stop button by twisting it clockwise until it pops out.
- d. Turn the Power Switch key to the OFF position—the Power Lamp should go out.
- e. Press the Start button.

—If the machine does not start, the Power Switch safety feature is working correctly.

—If the machine does start with the Power Switch key turned to the OFF position, immediately disconnect power to the machine. The Power Switch safety feature is not working correctly. This safety feature must work properly before proceeding with regular operations. Call Tech Support for help.

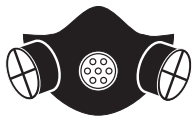


# SECTION 4: OPERATIONS

## Operation Safety

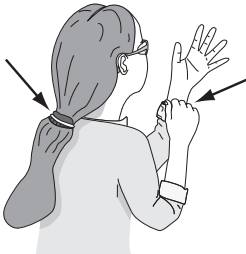
### **!WARNING**

Damage to your eyes and lungs could result from using this machine without proper protective gear. Always wear safety glasses and a respirator when operating this machine.



### **!WARNING**

Loose hair and clothing could get caught in machinery and cause serious personal injury. Keep loose clothing and long hair away from moving machinery.



### **NOTICE**

If you have never used this type of machine or equipment before, WE STRONGLY RECOMMEND that you read books, trade magazines, or get formal training before beginning any projects. Regardless of the content in this section, Grizzly Industrial will not be held liable for accidents caused by lack of training.

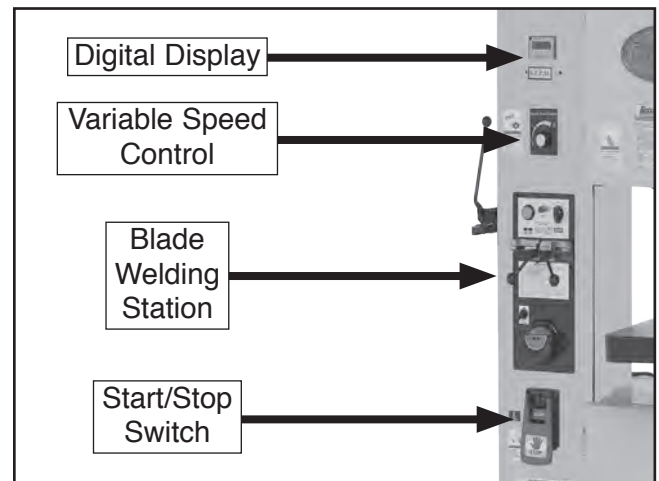
## Basic Controls

Use the descriptions and figures below to become familiar with the basic controls of your bandsaw.

### **Model G8144Z/G8145Z**

**Digital Speed Display:** Shows the blade speed in feet per minute (FPM).

**Variable Speed Control:** Adjusts the blade speed between 104–1300 FPM (Model G8144Z) or 108–1800 FPM (Model G8145Z).



**Figure 12.** Model G8144Z/G8145Z electrical controls.

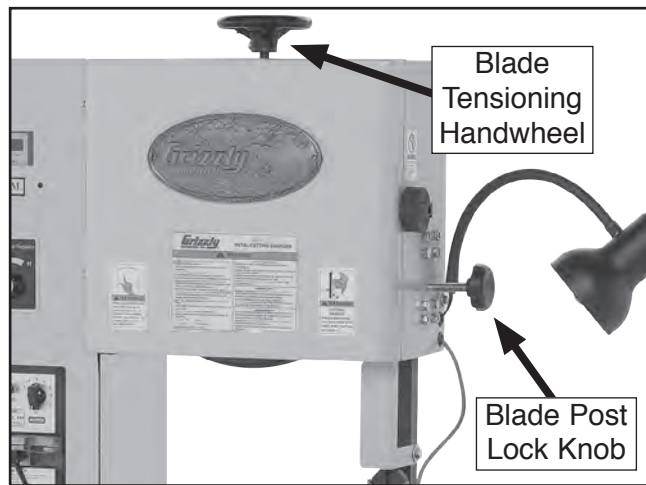
**Blade Welding Station:** Welds two blade ends to make a continuous loop when repairing a broken blade, fabricating a new blade, or making internal contour cuts.

**Bandsaw Start/Stop Switch:** Turns power ON/OFF to the bandsaw motor.



**Blade Tensioning Handwheel:** Increases/decreases blade tension when rotated.

**Blade Post Lock Knob:** Secures the blade post and upper blade guide assembly in position.



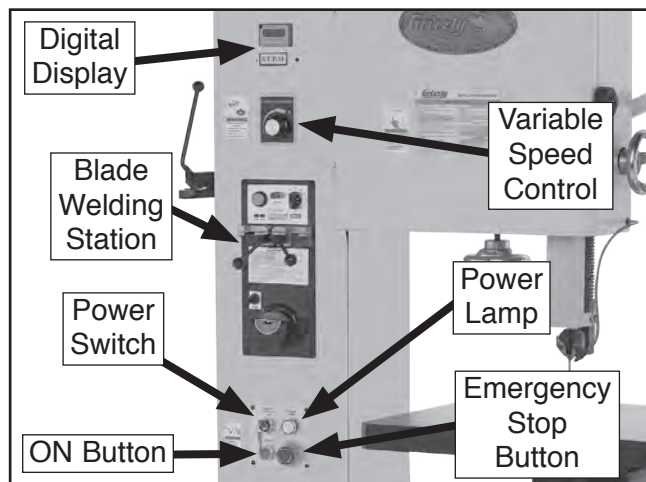
**Figure 13.** Model G8144Z/G8145Z blade controls.

## Model G8146Z

**Digital Speed Display:** Shows blade speed in feet per minute (FPM).

**Variable Speed Control:** Adjusts the blade speed between 105–2100 FPM.

**Blade Welding Station:** Welds two blade ends to make a continuous loop when repairing a broken blade, fabricating a new blade, or making internal contour cuts.



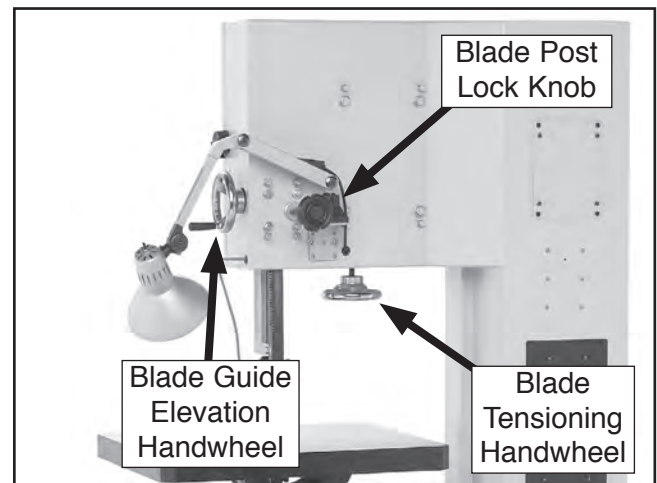
**Figure 14.** Model G8146Z electrical controls.

**Power Switch:** The main power switch for the entire machine.

**Power Lamp:** Lights when the Power Switch is turned **ON** and there is power to the machine.

**ON Button:** Turns the bandsaw motor **ON**.

**Emergency Stop Button:** Turns the bandsaw motor **OFF**.

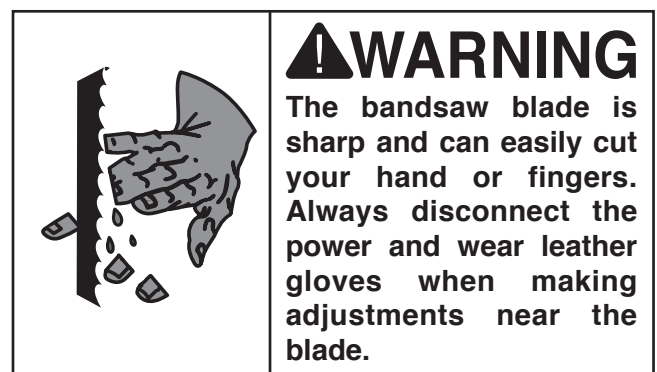


**Figure 15.** Model G8146Z blade controls.

**Blade Post Lock Knob:** Secures the blade post and upper blade guide assembly in position.

**Blade Guide Elevation Handwheel:** Raises/lowers the blade post and upper blade guide assembly when rotated.

**Blade Tensioning Handwheel:** Increases/decreases blade tension when rotated.



# Blade Selection

Selecting the right blade for the cut requires a knowledge of various blade characteristics.

## Blade Terminology

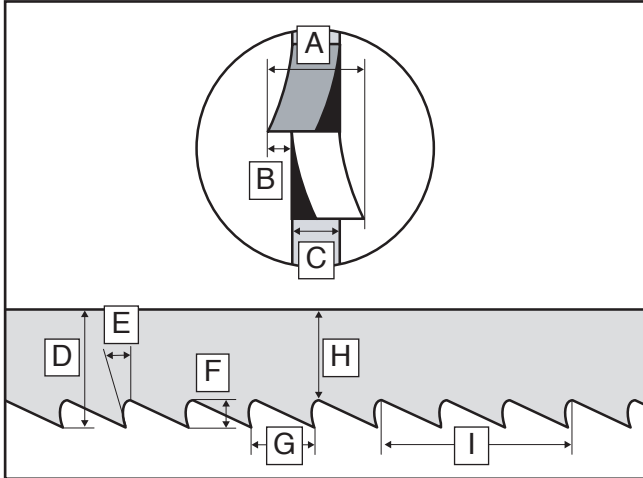


Figure 16. Bandsaw blade terminology.

- A. Kerf:** The amount of material removed by the blade during cutting.
- B. Tooth Set:** The amount each tooth is bent left or right from the blade.
- C. Gauge:** The thickness of the blade.
- D. Blade Width:** The widest point of the blade measured from the tip of the tooth to the back edge of the blade.
- E. Tooth Rake:** The angle of the tooth face from a line perpendicular to the length of the blade.
- F. Gullet Depth:** The distance from the tooth tip to the bottom of the curved area (gullet).
- G. Tooth Pitch:** The distance between tooth tips.
- H. Blade Back:** The distance between the bottom of the gullet and the back edge of the blade.
- I. TPI:** The number of teeth per inch measured from gullet to gullet.

## Blade Length

Measured by the blade circumference, blade lengths are usually unique to the brand of your bandsaw and the distance between the wheels.

Model	Blade Length Range
G8144Z.....	94 <sup>1</sup> / <sub>4</sub> "–98 <sup>1</sup> / <sub>4</sub> "
G8145Z.....	105"–110"
G8146Z.....	133"–136"

## Blade Width

Measured from the back of the blade to the tip of the blade tooth (the widest point), blade width is often the first consideration given to blade selection. Blade width dictates the largest and smallest curve that can be cut, as well as how accurately it can cut a straight line—generally the wider the blade, the straighter it will cut.

Model	Blade Width Range
G8144Z.....	<sup>1</sup> / <sub>8</sub> "– <sup>3</sup> / <sub>8</sub> "
G8145Z.....	<sup>1</sup> / <sub>8</sub> "– <sup>1</sup> / <sub>2</sub> "
G8146Z.....	<sup>1</sup> / <sub>8</sub> "– <sup>3</sup> / <sub>4</sub> "

Always pick the blade width that best suits your operation.

**Curve Cutting:** Use the chart in **Figure 17** to choose the correct blade for curve cutting. Determine the smallest radius curve that will be cut on your workpiece and use the corresponding blade width.

The list below shows the minimum radius that can be cut by common blade widths.

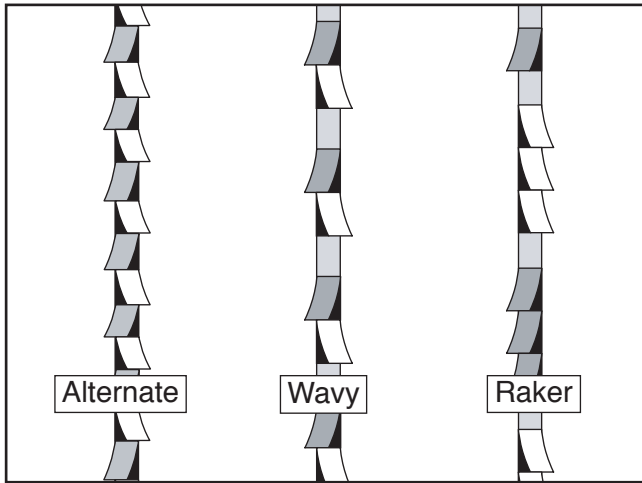
Width	Radius
<sup>1</sup> / <sub>8</sub> ".....	<sup>1</sup> / <sub>8</sub> "
<sup>3</sup> / <sub>16</sub> ".....	<sup>3</sup> / <sub>8</sub> "
<sup>1</sup> / <sub>4</sub> ".....	<sup>5</sup> / <sub>8</sub> "
<sup>3</sup> / <sub>8</sub> ".....	1 <sup>1</sup> / <sub>4</sub> "
<sup>1</sup> / <sub>2</sub> ".....	2 <sup>1</sup> / <sub>2</sub> "
<sup>5</sup> / <sub>8</sub> ".....	3 <sup>3</sup> / <sub>4</sub> "
<sup>3</sup> / <sub>4</sub> ".....	5 <sup>1</sup> / <sub>2</sub> "

Figure 17. Blade width radii.



## Tooth Set

Three common tooth sets are standard, wavy, and raker (see **Figure 18**), each removing material in a different manner to make the kerf in the workpiece.



**Figure 18.** Bandsaw tooth sets.

**Alternate:** An all-purpose arrangement of bending the teeth evenly left and right of the blade. Generally used for milder metals.

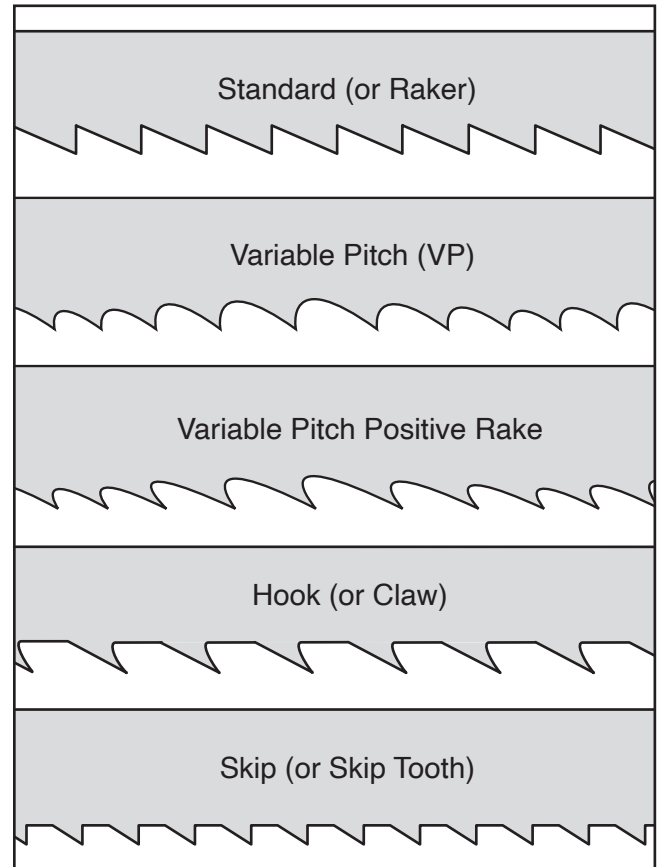
**Wavy:** Generally three or more teeth in a group that are bent one way, followed by a non-set tooth, and then a group bent the other way. Recommended for straight cuts in thin metals or thin-wall tubing.

**Raker:** Three teeth in a recurring group—one bent left, next one bent right, and then a non-set tooth. The raker set is ideal for most contour cuts.

## Tooth Type

The most common tooth types are described below and illustrated in **Figure 19**.

**Standard or Raker:** Equally spaced teeth set a "0" rake angle. Recommended for all purpose use.



**Figure 19.** Bandsaw blade tooth types.

**Variable Pitch (VP):** Varying gullet depth and tooth spacing, a "0" rake angle, excellent chip removing capacity, and smooth cutting.

**Variable Pitch with Positive Rake:** Varying gullet depth and tooth spacing, a positive rake angle, better chip formation, and aggressive cutting.

**Hook or Claw:** Wide gullets (round or flat), equally spaced teeth, positive rake angle, and fast cut with good surface finish.

**Skip or Skip Tooth:** Wide, flat gullets, a "0" rake angle, equally spaced teeth, and recommended for non-ferrous materials.



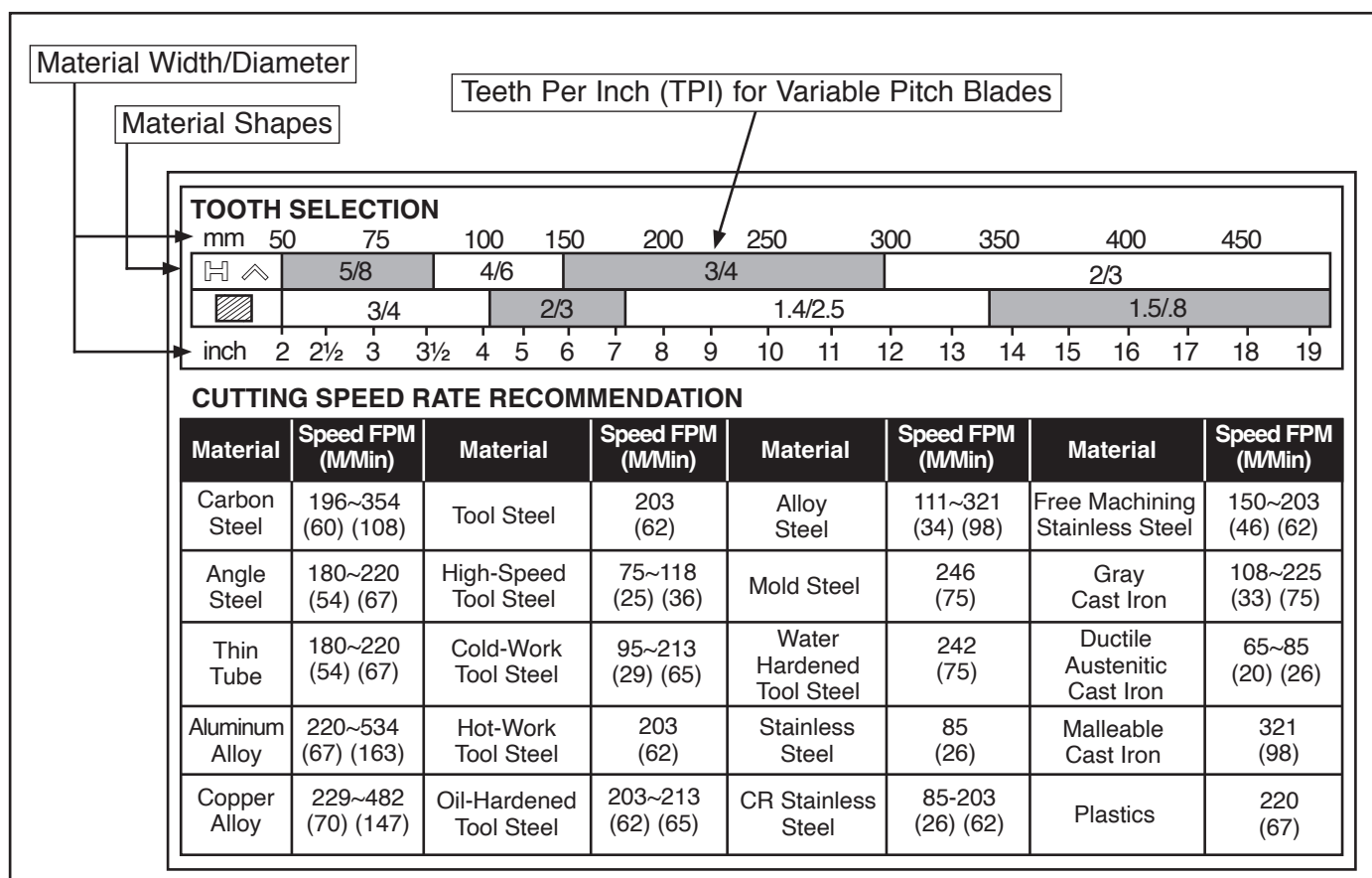
## Blade Pitch (TPI)

The chart below is a basic starting point for choosing teeth per inch (TPI) for variable tooth pitch blades and standard raker set bi-metal blades/HSS blades. However, for exact specifications of bandsaw blades that are correct for your operation, contact the blade manufacturer.

### To select the correct blade pitch:

1. Measure the material thickness. This measurement is the length of cut taken from where the tooth enters the workpiece, sweeps through, and exits the workpiece.
2. Refer to the "Material Width/Diameter" row of the blade selection chart in **Figure 20**, and read across to find the workpiece thickness you need to cut.

3. Refer to the "Material Shapes" row and find the shape of the material to be cut.
4. In the applicable row, read across to the right and find the box where the row and column intersect. Listed in the box is the minimum TPI recommended for the variable tooth pitch blades.
5. The "Cutting Speed Rate Recommendation" section of the chart offers guidelines for various metals, given in feet per minute (FPM). Choose the speed closest to the number shown in the chart.



**Figure 20.** General guidelines for blade selection and speed chart.



# Blade Breakage

---

Many conditions may cause a bandsaw blade to break. Blade breakage is unavoidable, in some cases, since it is the natural result of the peculiar stresses that bandsaw blades must endure. Blade breakage is also due to avoidable circumstances. Avoidable blade breakage is most often the result of poor care or judgement on the part of the operator when mounting or adjusting the blade or support guides.

## The most common causes of blade breakage are:

- Faulty alignment or adjustment of the blade guides.
- Forcing or twisting a wide blade around a short radius.
- Feeding the workpiece too fast.
- Dull or damaged teeth.
- Over-tensioned blade.
- Top blade guide assembly set too high above the workpiece. Adjust the top blade guide assembly so that there is approximately  $\frac{1}{8}$ "– $\frac{1}{4}$ " between the bottom of the assembly and the workpiece.
- Using a blade with a lumpy or improperly finished braze or weld.
- Continuously running the bandsaw when not in use.
- Leaving the blade tensioned when not in use.
- Using the wrong pitch (TPI) for the workpiece thickness. The general rule of thumb is to have not less than two teeth in contact with the workpiece at all times during cutting.

# Blade Care & Break-In

---

## Blade Care

A bandsaw blade is a delicate piece of steel that is subjected to tremendous strain. You can obtain longer use from a bandsaw blade if you give it fair treatment and always use the appropriate feed rate for your operation.

Be sure to select blades with the proper width, set, type, and pitch for each application. The wrong blades will produce unnecessary heat and shortens the life of the blade.

A clean blade will perform much better than a dirty blade. Dirty or gummed up blades pass through the cutting material with much more resistance than clean blades. This extra resistance also causes unnecessary heat.

## Blade Break-In

The sharp teeth tips and edges of a new blade are extremely sharp, and cutting at too fast of a feed rate fractures the beveled edges of the teeth and causes premature blade wear.

### To properly break-in a new blade:

1. Choose the correct speed for the blade and material of the operation.
2. Reduce the feed pressure by half for the first 50–100 in<sup>2</sup> of material cut.
3. To avoid twisting the blade when cutting, adjust the feed pressure when the total width of the blade is in the cut.
4. Use the **Chip Inspection Chart** on **Page 27** to check the blade efficiency.



# Chip Inspection Chart

The best method of evaluating the performance of your cutting operation is to inspect the chips that are formed. Refer to the chart below for chip inspection guidelines.

Chip Appearance	Chip Description	Chip Color	Blade Speed	Feed Pressure	Additional Actions
	Thin & Curled	Silver	<b>Good</b>	<b>Good</b>	
	Hard, Thick & Short	Brown or Blue	Decrease	Decrease	Check Cutting Fluid Mix
	Hard, Strong & Thick	Brown or Blue	Decrease	Decrease	Check Cutting Fluid Mix
	Hard, Strong & Thick	Silver or Light Brown	<b>Good</b>	Decrease Slightly	Check Blade Pitch
	Hard & Thin	Silver	Increase	Decrease	Check Blade Pitch
	Straight & Thin	Silver	<b>Good</b>	Increase	
	Powdery	Silver	Decrease	Increase	
	Curled Tight & Thin	Silver	<b>Good</b>	Decrease	Check Blade Pitch

**Figure 21.** Chip inspection chart.



# Cutting Overview

The vertical metal cutting bandsaw has a flexible continuous blade that cuts in one direction. The type of bandsaw blade and the speed of the blade to be used depends on the workpiece material and the type of cut required.

This type of bandsaw can be used for straight cuts, angular cuts, and curved or contour cuts. Straight cuts are made using workpiece fixtures and with a light, even pressure against the blade. Angular cuts are made with the table and workpiece tilted at an angle other than "0".

When an internal contour cut is to be made, a hole must be drilled in the workpiece. The blade is then cut, fed through the hole in the workpiece, welded together again using the welding station, and re-installed on the bandsaw to make the cut. The welding station can also be used to fabricate new blades and repair broken blades.

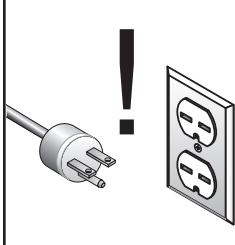
The blade is supported by upper and lower tungsten steel blade guides that keep the blade from wandering during the cut.


The efficiency of the cutting operation can be easily checked by examining the form and color of the metal chips.

## **WARNING** **ELECTROCUTION HAZARD**

This bandsaw is not designed to be used with water soluble cutting fluid or coolant. If needed, use a small amount of oil-based lubricant.

# Blade Changes

	<b>! WARNING</b> Always disconnect power to the machine when changing blades. Failure to do this may result in serious personal injury.
--	--

	<b>! CAUTION</b> All saw blades are dangerous and may cause personal injury. To reduce the risk of being injured, wear leather gloves when handling saw blades.
--	--

## To replace the blade:

1. DISCONNECT BANDSAW FROM POWER!
2. Open the upper and lower wheel doors.
3. Release tension on the blade by rotating the tensioning handwheel.
4. Put on heavy gloves, then slide the blade off the upper and lower wheels, around the blade post, and through the table slit.
5. Install a new blade in reverse order.

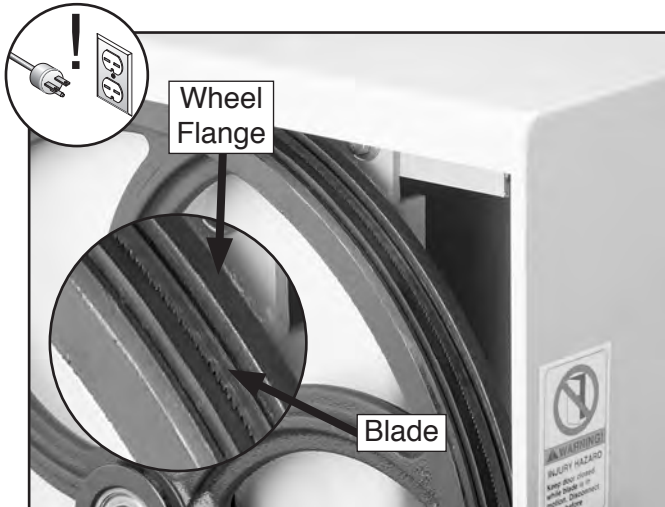
## **WARNING**

Workpieces that cannot be supported or stabilized without a vise or jig should not be cut on a vertical metal-cutting bandsaw, because they can unexpectedly move while cutting and draw the operator's hands into the blade causing serious personal injury. Examples are chains, cables, round or oblong-shaped workpieces, workpieces with internal or built-in moving or rotations parts, etc.



- Position the back edge of the blade so that it is next to, but not against, the flange of the top wheel (see **Figure 22**).

**Note:** Excessive blade contact with the wheel flange during operation could lead to blade and wheel damage.



**Figure 22.** Back edge of blade next to wheel flange.

- Rotate the top wheel by hand several times to make sure the blade tracks evenly without wandering across the wheel surface.
- Re-tension the blade (refer to **Blade Tensioning** on this page).
- Check the upper and lower blade guides for clearance (refer to **Adjusting Blade Guides** on **Page 31**).

**Note:** Generally if the replacement blade is the same gauge, width, and type, blade guide adjustment is not necessary. Otherwise, you must adjust the blade guides.

- Close and secure the upper and lower wheel doors.

## Blade Tensioning

### NOTICE

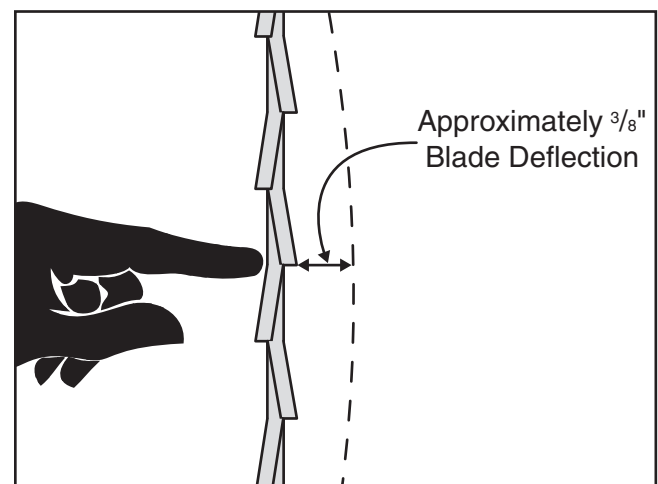
To prolong blade life, release the tension on the blade if the machine will be idle for an extended period of time.

Proper blade tension reduces the risk of blade breakage and improves cutting performance.

#### To correctly tension the blade:

- DISCONNECT BANDSAW FROM POWER!
- Open the upper wheel door, and raise the blade post and upper blade guide assembly to the highest position.
- Check the side-to-side deflection of the blade midway between the upper blade guide and the table. The proper amount of deflection should be approximately  $\frac{3}{8}$ " when moderate pressure is applied (see **Figure 23**).

**Note:** The quickest and easiest way to check blade tension is to use the Model H5408 Blade Tensioning Gauge to reach a blade tension of 25,000–30,000 PSI (refer to **Page 36**)



**Figure 23.** Blade deflection when correctly tensioned.



4. Make small adjustments to the blade tensioning handwheel, then rotate the top wheel by hand several times before checking the blade deflection again. Repeat this step until you are satisfied.

**Note:** Make sure the blade tracks next to, but not touching, the upper wheel flange as you rotate the upper wheel by hand.

5. Close the upper wheel door and reposition the guide post.

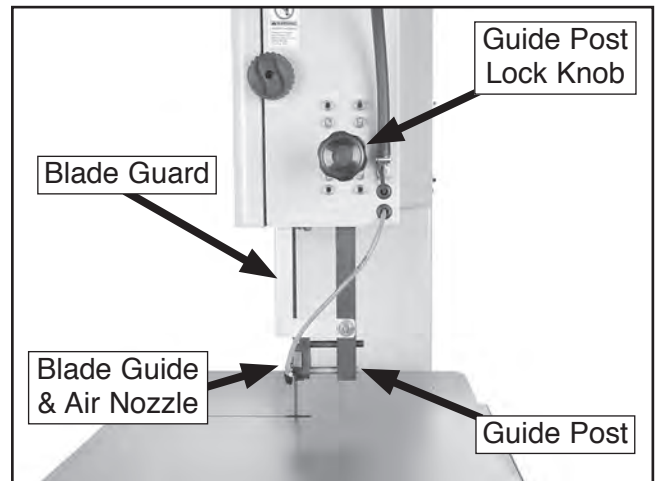
## Guide Post

The guide post assembly is used for two purposes: 1) To properly position the blade guard to protect the operator from the exposed blade between the workpiece and the upper wheel housing, and 2) to position the upper blade guides close to the workpiece for blade support.

In order to cut accurately and safely, position the bottom of the upper blade guides approximately 1/4" above the workpiece—this positioning provides the greatest blade support and minimizes the amount of blade exposed to the operator during operation.

### To properly position the guide post:

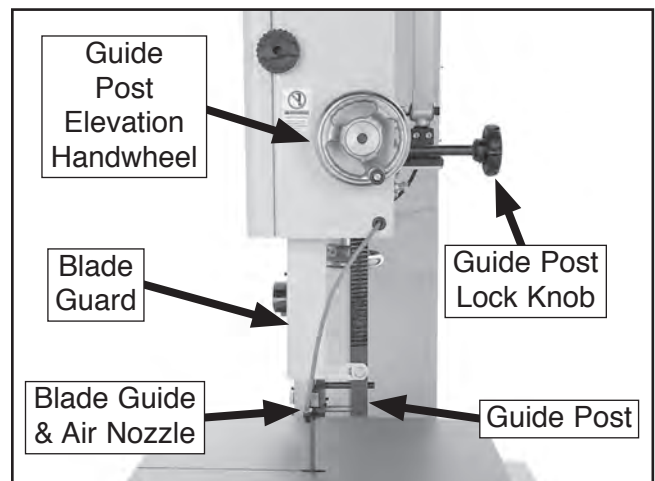
1. DISCONNECT BANDSAW FROM POWER!
2. **Model G8144Z/G8145Z (Figure 24):**
  - a. Hold the guide post with one hand and loosen the guide post lock knob with the other.
  - b. Position the bottom of the upper blade guides approximately 1/4" above the workpiece, then re-tighten the lock knob to secure the setting.



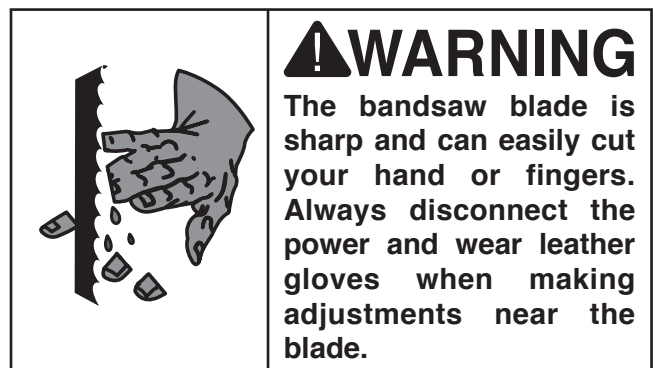
**Figure 24.** Model G8144Z/G8145Z guide post assembly.

### 3. **Model G8146Z (Figure 25):**

- a. Loosen the guide post lock knob.
- b. Use the guide post elevation handwheel to position the bottom of the upper blade guides approximately 1/4" above the workpiece, then re-tighten the lock knob.



**Figure 25.** Model G8146Z guide post assembly.

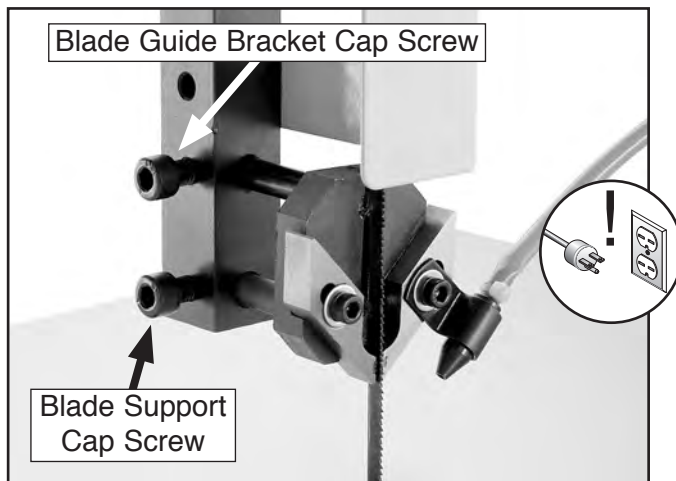


# Adjusting Blade Guides

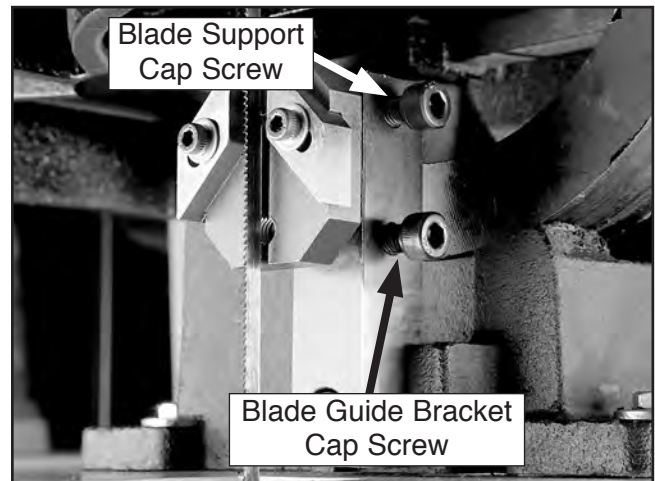
The blade guides provide side-to-side and back support to keep the blade straight while cutting. The blade guides and the back support have tungsten steel facing to reduce wear on the guides. Properly adjusted blade guides are essential to making accurate cuts.

**To properly adjust the upper and lower blade guides:**

1. DISCONNECT BANDSAW FROM POWER!
2. Make sure the bandsaw blade is properly tensioned (**Page 29**) and the blade post is in the correct position and locked.
3. Use a 6mm hex wrench to loosen the cap screws that secure the blade guide bracket and blade support (see **Figures 26–27**).

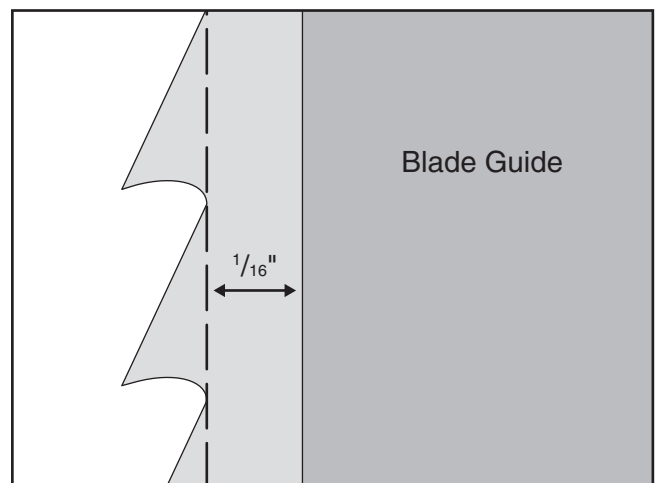


**Figure 26.** Upper blade guides and bracket.



**Figure 27.** Lower blade guides and bracket.

4. Position the blade guides so that they are approximately  $\frac{1}{16}$ " behind the tooth gullets (see **Figure 28**), then re-tighten the blade guide bracket cap screw.

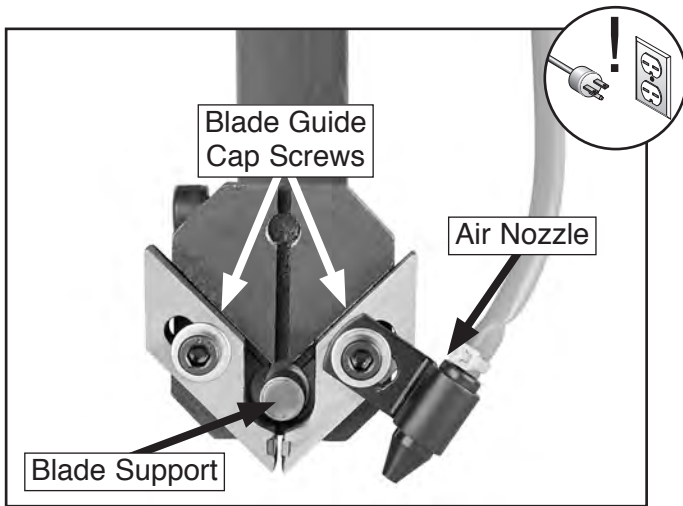


**Figure 28.** Blade guides positioned approximately  $\frac{1}{16}$ " behind tooth gullets.

**Note:** The blade guards must be adjusted far enough back so that they are behind the tooth gullets when the blade is deflected back against the blade support.

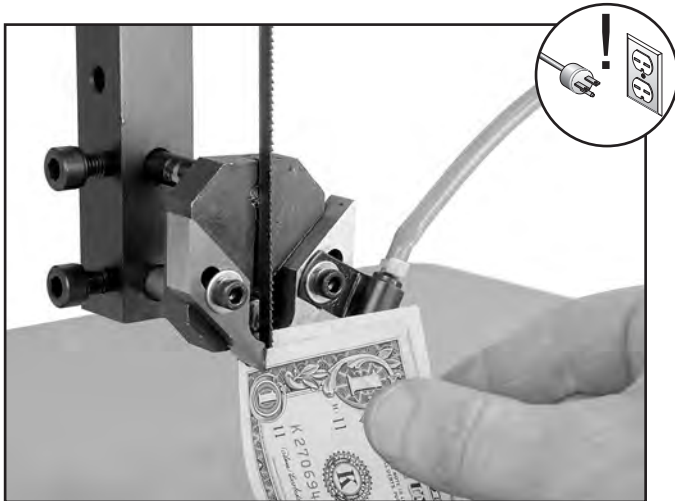


- Slide the blade support (see **Figure 29**) up to, but not touching, the back of the blade, then re-tighten the blade support cap screw.



**Figure 29.** Blade guide assembly (upper assembly shown without blade for clarity).

- Rotate the upper wheel by hand so that the blade weld is between the blade guides.
- Use a 4mm hex wrench to loosen the blade guide cap screws (see **Figure 29**).
- Fold a crisp dollar bill in half and place it over the blade (between the blade guides and the blade), as shown in **Figure 30**.



**Figure 30.** Using a dollar bill to set blade guide spacing.

- Lightly pinch the dollar bill against the blade with the blade guides, re-position the air nozzle if necessary, then re-tighten the blade guide cap screws.

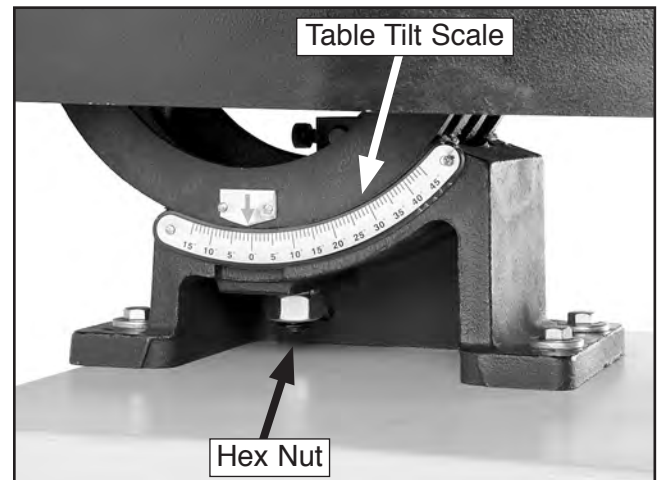
**Note:** The goal is to position the blade guides as close as possible to the blade without touching it during operation.

## Adjusting Table Tilt

To perform beveled cuts, the bandsaw table tilts 15° to the left and 45° to the right.

**To adjust the table tilt:**

- DISCONNECT BANDSAW FROM POWER!
- Use a 23mm wrench to loosen the hex nut underneath the rear of the table (see **Figure 31**).



**Figure 31.** Table tilt scale and hex nut.

- Using the table tilt scale, adjust the angle of the table for your operation, then re-tighten the hex nut.



# Blade Welding

Being able to quickly and safely weld a bandsaw blade comes in handy for the following situations:

- To repair a broken blade that is still sharp and useful.
- To fabricate a new blade from a larger section of blade material to fit your bandsaw.
- To re-join a blade that has been purposely cut for making an internal contour cut.

Your metal cutting bandsaw is equipped with a blade welder that uses electrical resistance to heat and fuse the blade ends together. This process will leave the joint brittle, so it will need to be annealed to give it strength and flexibility.

## **⚠️ WARNING**

The electric current that flows through the blade welder during operation could cause serious personal injury or death. To avoid the risk of electrocution, never touch any metal part of the welding station during blade welding or annealing.

To weld the ends of bandsaw together:

1. Turn the bandsaw motor **OFF**.
2. Place the blade evenly against the back of the blade shear and firmly pull the handle down to square off the blade end (see **Figure 32**).

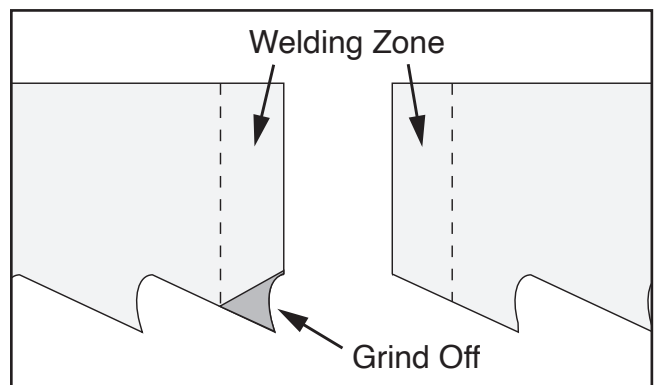


**Figure 32.** Using the blade shear to cut the blade.

**Note:** To make a proper blade weld, the ends of the blade must be evenly butted together during the welding process. If necessary, use the grinder to square up the ends or remove any teeth that are in the welding zone (see **Figures 33–34**).



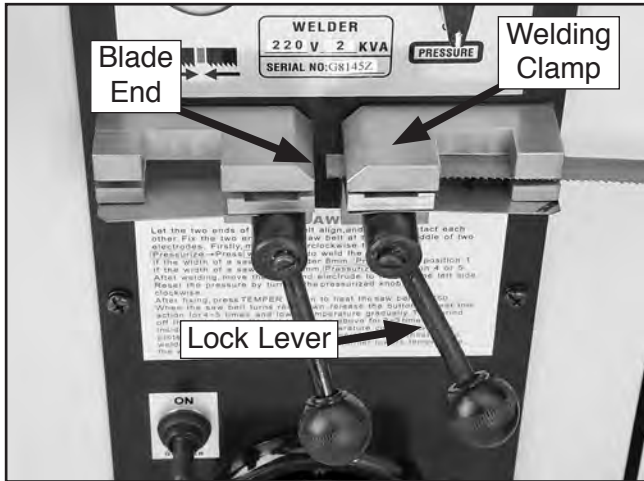
**Figure 33.** Using the grinder to square up the blade end.



**Figure 34.** Blade ends and welding zone.



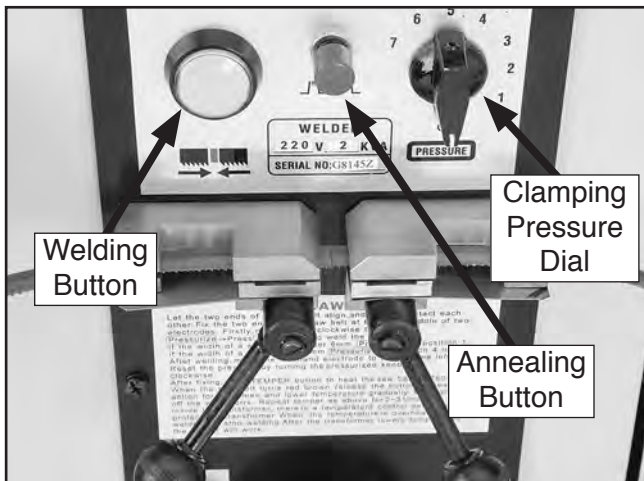
- Loosen the welding clamps by pulling the lock levers down.
- Position the back of one blade end evenly against the back of the welding clamp so that the end is midway between the two clamps, then rotate the lock lever all the way up to hold the blade end in place (see **Figure 35**).



**Figure 35.** Blade end properly positioned in welding clamp and locked in place.

- Set the clamping pressure dial (see **Figure 36**) to "0".

**Note:** As the blade material melts to form the weld, pressure is applied to the joint by the welding clamps. The correct amount of pressure is set with the clamping pressure dial in a later step.



**Figure 36.** Blade ends in correct position for welding.

- Place the other blade end in the opposite welding clamp and position it so that it evenly butts up against the opposing blade end, then lock it in place by rotating the lock lever all the way up, as shown in **Figure 36**.

**Note:** For a good blade weld, it is critical that the blade ends evenly butt up against each other.

- Use the chart in **Figure 37** and set the correct clamping pressure setting for the blade.

Blade Width	Pressure Setting
Up to 1/4"	1
1/4" to 3/8"	2-3
Above 3/8"	4+

**Figure 37.** Blade clamping pressure chart.

**⚠ WARNING**

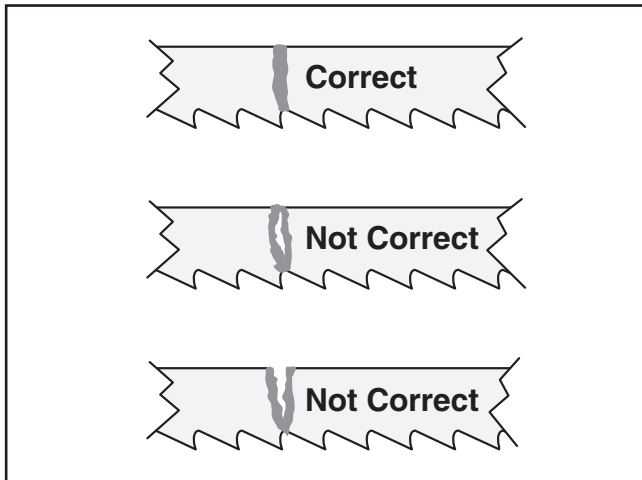
**Burning sparks from the blade welding operation may be thrown in all directions and could cause serious personal injury or fire. When using the blade welder, always protect yourself from the flying sparks and have fire extinguishing equipment readily available. DO NOT weld near flammables.**

- Press and release—DO NOT hold—the welding button.

**Note:** There is a limit switch that senses the electrical resistance between the blade ends. If there is an adequate amount of welded material, the limit switch will not allow the welding button to activate the operation again.



9. Rotate the lock levers down to release the welding clamps, then rotate the clamping pressure dial to "0".
10. Inspect the weld. The welded joint should be even across the width of the blade with no gaps (see **Figure 38**).



**Figure 38.** Blade welded joint examples.

- If the weld is satisfactory, continue to **Step 11**.
- If the weld is NOT satisfactory, begin again at **Step 2**.

11. Set the clamping pressure dial to 4 or greater to bring the welding clamps close together.
12. Place the blade in the welding clamps with the weld centered between the clamps and re-tighten the lock levers.

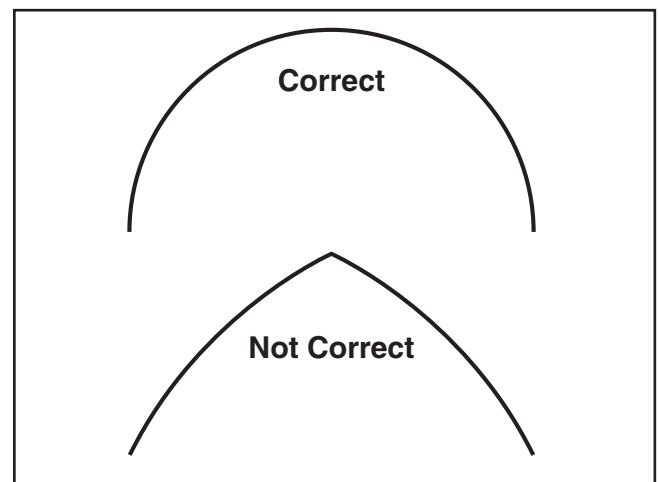
**Note:** *The welding operation has left the blade joint brittle. Annealing will allow the material to cool in gradual manner, giving the weld strength and flexibility.*

13. Rapidly press and release—DO NOT hold—the annealing button two or three times until the weld zone turns dull red.
14. Repeat **Step 13** three to four more times, allowing the weld to cool for about 30 seconds between each repetition.

15. Allow the blade to cool, then re-inspect the weld.
16. Grind away the weld flash flat on the top and bottom of the joint so that the blade will run smoothly on the wheels.

**Note:** *Make sure not to grind the teeth or blade body, or overheat the blade during grinding—this will weaken the blade.*

17. Re-clamp the blade in the welding clamps with the joint centered, then repeat **Step 13** twice more.
18. Test the strength and flexibility of the weld by bending the blade in an arc similar to that of the bandsaw wheels. The blade should bend smoothly without any angles (see **Figure 39**).



**Figure 39.** Correct blade weld bend for strength and flexibility.

## **NOTICE**

**For good metal-to-metal contact between the welding clamps and the blade, make sure the blade material and the clamps are free from any debris or flash before each use.**



# SECTION 5: ACCESSORIES

- T20501—Face Shield Crown Protector 4"
- T20502—Face Shield Crown Protector 7"
- T20503—Face Shield Window
- T20452—"Kirova" Anti-Reflective S. Glasses
- T20451—"Kirova" Clear Safety Glasses
- H0736—Shop Fox® Safety Glasses
- H7194—Bifocal Safety Glasses 1.5
- H7195—Bifocal Safety Glasses 2.0
- H7196—Bifocal Safety Glasses 2.5



Figure 40. Eye protection assortment.

## H5408—Blade Tensioning Gauge

The Blade Tensioning Gauge ensures long blade life, reduced blade breakage, and straight cutting by indicating correct tension. A precision dial indicator provides you with a direct readout in PSI.



Figure 41. H5408 Blade Tensioning Gauge.

Call 1-800-523-4777 To Order

## Grizzly Bandsaw Blades

Model	Material	Length	Width	TPI /Style
G8803	Tool Steel	97"	1/4"	6/Hook
G8804	Tool Steel	97"	1/4"	14/Raker
G8805	Bi-Metal	97"	1/4"	6/Hook
G8806	Bi-Metal	97"	1/4"	10-14/VP
G8807	Bi-Metal	97"	1/2"	10-14/VP
G8808	Tool Steel	108"	1/4"	6/Hook
G8809	Tool Steel	108"	1/4"	14/Raker
G8810	Bi-Metal	108"	1/4"	6/Hook
G8811	Bi-Metal	108"	1/4"	10-14/VP
G8812	Bi-Metal	108"	1/2"	10-14/VP
G8813	Tool Steel	134"	1/4"	6/Hook
G8814	Tool Steel	134"	1/4"	14/Raker
G8815	Bi-Metal	134"	1/4"	6/Hook
G8816	Bi-Metal	134"	1/4"	10-14/VP
G8817	Bi-Metal	134"	1/2"	10-14/VP

## G5562—SLIPIT® 1 Qt. Gel

## G5563—SLIPIT® 12 oz Spray

## G2871—Boeshield® T-9 12 oz Spray

## H3788—G96® Gun Treatment 12 oz Spray



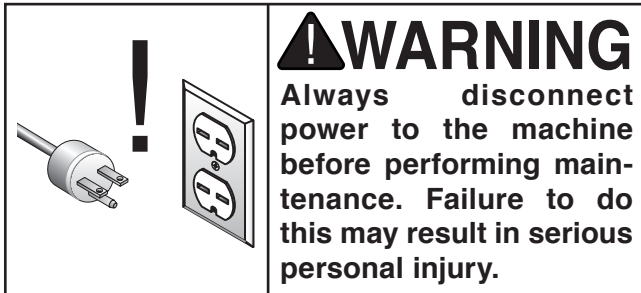
Figure 42. Recommended products for protecting unpainted cast iron/steel part on machinery.

G8144Z/G8145Z/G8146Z  
(Manufactured Since 6/11)



# SECTION 6: MAINTENANCE

---



## Schedule

---

For optimum performance from your machine, follow this maintenance schedule and refer to any specific instructions given in this section.

### Daily:

- Check/correct loose mounting bolts.
- Check/correct damaged or dull saw blade.
- Check/correct worn or damaged wires.
- Clean/protect table.
- Clean metal chips from upper and lower wheel areas, and empty bottom chip pan.
- Correct any other unsafe condition.

### Monthly:

- Check for V-belt tension, damage, or wear.
- Lubricate tension leadscrews and guide post rack.
- Remove the blade and clean the wheels.

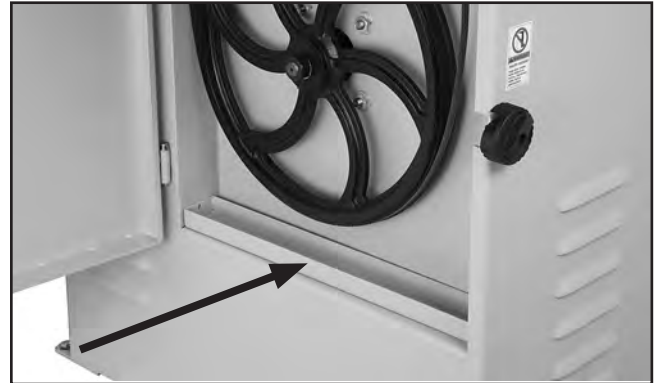
## Cleaning

---

Use a brush and a shop vacuum to remove chips and other debris from the machine. Keep the table rust-free with regular applications of products like G96® Gun Treatment, SLIPIT®, or Boeshield® T-9 (see **Section 5: Accessories** on **Page 36** for more details).

Once a month, remove the blade and thoroughly clean all metal chips or built-up grease from the wheel surfaces. Redress the rubber tires if necessary.

When cleaning the wheel areas, empty and clean the chip pan (see **Figure 43**).



**Figure 43.** Lower wheel chip pan.

## Redressing Rubber Tires

---

As the bandsaw ages, the rubber tires on the wheel may need to be redressed if they become hardened or glazed over. Redressing the rubber tires improves blade tracking and reduces vibration/blade lead.

If the rubber tires become too worn, then blade tracking will become extremely difficult. At that point, redressing will no longer be effective, and the rubber tires must be replaced.

### To redress the rubber tires:

1. DISCONNECT BANDSAW FROM POWER!
2. Put on heavy gloves and remove the blade.
3. Use a brush and shop vacuum to clean any chips from the rubber tires.
4. Hold a piece of 100-grit sandpaper against the rubber tire and rotate the wheel by hand. Only redress the rubber enough to expose a fresh rubber surface.

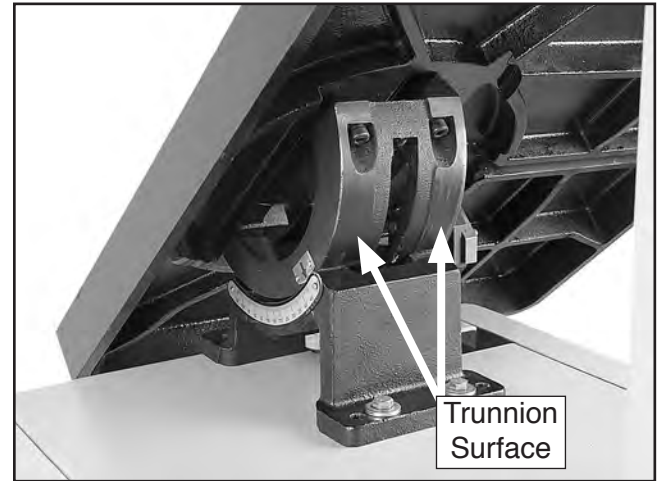


# Lubrication

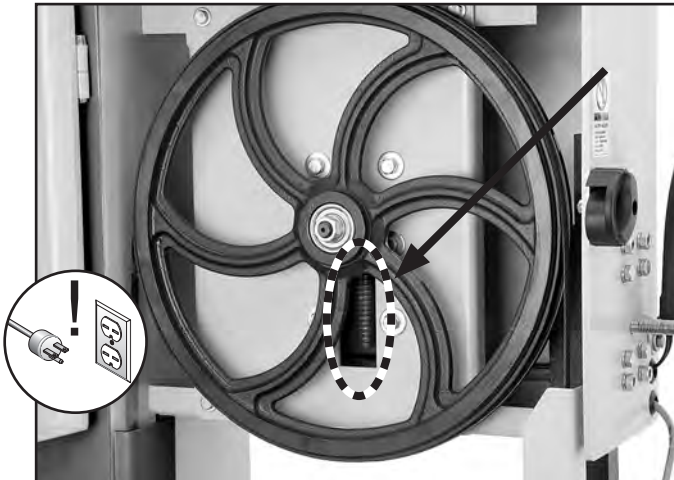
The bearings on your bandsaw are factory lubricated and sealed. Merely leave them alone unless they need to be replaced.

When needed, brush a light coat of multi-purpose grease on the tension leadscrew (all Models) and guide post rack (Model G8146Z only) to maintain smooth operation (see **Figures 44 & 45**).

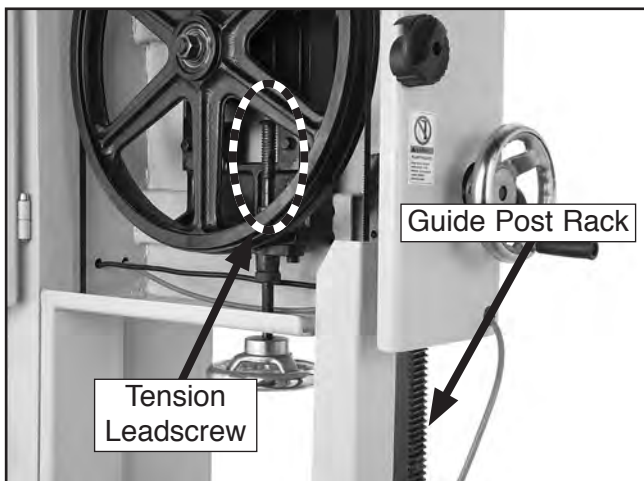
If the table becomes difficult to tilt, position it so that you can brush a thin coat of multi-purpose grease on the trunnion surface (see **Figure 46**).



**Figure 46.** Table tilted to expose trunnion surface.



**Figure 44.** Model G8144Z/G8145Z tension leadscrew.



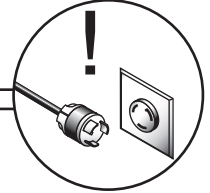
**Figure 45.** Model G8146Z tension leadscrew and guide post rack.



# SECTION 7: SERVICE

Review the troubleshooting and procedures in this section to fix or adjust your machine if a problem develops. If you need replacement parts or you are unsure of your repair skills, then feel free to call our Technical Support at (570) 546-9663.

## Troubleshooting



### Motor & Electrical

Symptom	Possible Cause	Possible Solution
Machine does not start or a breaker trips.	<ol style="list-style-type: none"> <li>1. Power switch key is removed or not in ON position (Model G8146Z only).</li> <li>2. Emergency stop push-button is engaged/faulty (Model G8146Z only).</li> <li>3. Plug/receptacle is at fault or wired incorrectly.</li> <li>4. Motor connection wired incorrectly.</li> <li>5. Wall fuse/circuit breaker is blown/tripped.</li> <li>6. Power supply switched OFF or is at fault.</li> <li>7. Wiring is open/has high resistance.</li> <li>8. Start/Stop switch is at fault (Model G8144Z/G8145Z).</li> <li>9. Inverter is at fault.</li> <li>10. Motor is at fault.</li> </ol>	<ol style="list-style-type: none"> <li>1. Install power switch key and turn it to the ON position.</li> <li>2. Rotate clockwise until it pops out; replace it if faulty.</li> <li>3. Test for good contacts; correct the wiring.</li> <li>4. Correct motor wiring connections (<b>Page 49</b>).</li> <li>5. Ensure circuit size is suitable for this machine; replace weak breaker.</li> <li>6. Ensure power supply is switched on; ensure power supply has the correct voltage.</li> <li>7. Check for broken wires or disconnected/corroded connections, and repair/replace as necessary.</li> <li>8. Replace Start/Stop switch.</li> <li>9. Replace inverter.</li> <li>10. Test/repair/replace.</li> </ol>
Machine stalls or is overloaded.	<ol style="list-style-type: none"> <li>1. Feeding workpiece too fast.</li> <li>2. Workpiece alignment is poor.</li> <li>3. Wrong workpiece material or blade.</li> <li>4. Blade is slipping on wheels.</li> <li>5. Motor connection is wired incorrectly.</li> <li>6. V-belt(s) slipping.</li> <li>7. Plug/receptacle is at fault.</li> <li>8. Pulley/sprocket slipping on shaft.</li> <li>9. Motor bearings are at fault.</li> <li>10. Machine is undersized for the task.</li> <li>11. Motor has overheated.</li> <li>12. Motor is at fault.</li> </ol>	<ol style="list-style-type: none"> <li>1. Reduce feed rate; increase blade speed.</li> <li>2. Eliminate workpiece binding; use jig, fence, guide, clamps, roller table, or push blocks as required for workpiece alignment control.</li> <li>3. Use metal with correct properties for your type of machining; match blade with workpiece and operation.</li> <li>4. Adjust blade tracking and tension (<b>Page 29</b>), redress rubber wheel tires if necessary (<b>Page 37</b>).</li> <li>5. Correct motor wiring connections (<b>Page 49</b>).</li> <li>6. Replace bad V-belt(s) as a matched set, align pulleys, and re-tension (<b>Page 41</b>).</li> <li>7. Test for good contacts; correct the wiring.</li> <li>8. Replace loose pulley/shaft.</li> <li>9. Test by rotating shaft; rotational grinding/loose shaft requires bearing replacement.</li> <li>10. Use sharp blade with lower TPI; reduce the feed rate; use a small amount of oil-based coolant if necessary.</li> <li>11. Clean off motor, let cool, and reduce workload.</li> <li>12. Test/repair/replace.</li> </ol>



## Motor & Electrical (continued)

Symptom	Possible Cause	Possible Solution
Machine has vibration or noisy operation.	<ol style="list-style-type: none"> <li>1. V-belt(s) worn or loose.</li> <li>2. Pulley is loose.</li> <li>3. Motor mount loose/broken.</li> <li>4. Machine is incorrectly mounted or sits unevenly.</li> <li>5. Workpiece is loose.</li> <li>6. Motor fan is rubbing on fan cover.</li> <li>7. Motor bearings are at fault.</li> <li>8. Blade is at fault.</li> </ol>	<ol style="list-style-type: none"> <li>1. Inspect/replace belts with a new matched set (<b>Page 41</b>).</li> <li>2. Realign/replace shaft, pulley, set screw, and key as required.</li> <li>3. Tighten/replace.</li> <li>4. Tighten/replace anchor studs in floor; relocate/shim machine.</li> <li>5. Use the correct holding fixture and reclamp workpiece.</li> <li>6. Replace dented fan cover; replace loose/damaged fan.</li> <li>7. Test by rotating shaft; rotational grinding/loose shaft requires bearing replacement.</li> <li>8. Re-tension/replace blade (<b>Pages 28 &amp; 29</b>).</li> </ol>

## Cutting Operations

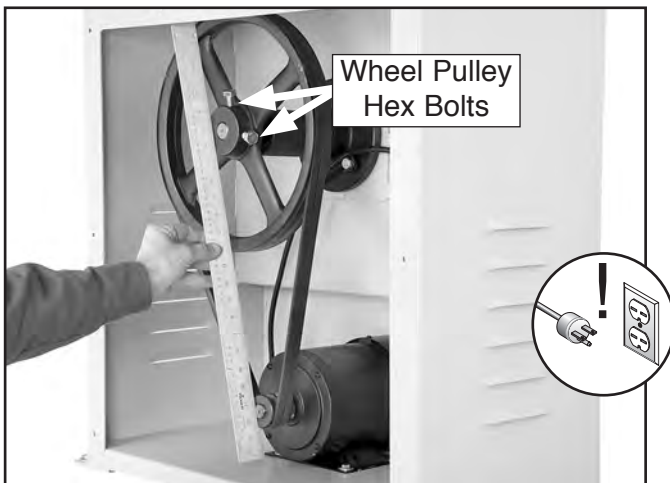
Symptom	Possible Cause	Possible Solution
Machine slows when operating.	<ol style="list-style-type: none"> <li>1. Feeding workpiece too fast.</li> <li>2. Blade is dull.</li> </ol>	<ol style="list-style-type: none"> <li>1. Reduce feed rate/increase blade speed.</li> <li>2. Replace blade (<b>Page 28</b>).</li> </ol>
Ticking sound when the saw is running.	<ol style="list-style-type: none"> <li>1. Blade weld contacting blade guide/support (a light ticking is normal).</li> <li>2. Blade weld may be failing.</li> </ol>	<ol style="list-style-type: none"> <li>1. Inspect/re-grind blade weld (<b>Page 33</b>); re-adjust blade guides/support (<b>Page 31</b>).</li> <li>2. Inspect weld and re-weld blade if necessary (<b>Page 33</b>), or replace blade (<b>Page 28</b>).</li> </ol>
Blade contacting table.	<ol style="list-style-type: none"> <li>1. Table improperly mounted or aligned.</li> </ol>	<ol style="list-style-type: none"> <li>1. Properly align table (<b>Page 42</b>).</li> </ol>
Vibration when cutting.	<ol style="list-style-type: none"> <li>1. Workpiece is loose.</li> <li>2. Loose or damaged blade.</li> <li>3. Metal chip buildup on wheels.</li> </ol>	<ol style="list-style-type: none"> <li>1. Use the correct holding fixture and reclamp workpiece.</li> <li>2. Re-tension/replace blade (<b>Pages 28 &amp; 29</b>).</li> <li>3. Clean metal chips from wheels.</li> </ol>
Rough or poor quality cuts.	<ol style="list-style-type: none"> <li>1. Feeding workpiece too fast.</li> <li>2. Incorrect blade for operation; worn or damaged blade.</li> <li>3. Blade guides/support adjusted incorrectly.</li> </ol>	<ol style="list-style-type: none"> <li>1. Reduce feed rate/increase blade speed.</li> <li>2. Use the correct blade for the operation (<b>Page 23</b>); replace worn or damaged blade (<b>Page 28</b>).</li> <li>3. Correctly adjust blade guides/support (<b>Page 31</b>); set the blade guides approximately 1/8" above workpiece.</li> </ol>
Blade wanders or doesn't cut straight.	<ol style="list-style-type: none"> <li>1. Blade lead.</li> <li>2. Metal chip buildup on wheels.</li> </ol>	<ol style="list-style-type: none"> <li>1. Re-tension/replace blade (<b>Pages 28 &amp; 29</b>).</li> <li>2. Clean metal chips from wheels.</li> </ol>
Cuts are not square (vertically).	<ol style="list-style-type: none"> <li>1. Table tilt is not adjusted to "0".</li> <li>2. Table is not square to the blade.</li> </ol>	<ol style="list-style-type: none"> <li>1. Adjust table to "0" tilt.</li> <li>2. Adjust table square with blade (<b>Page 42</b>).</li> </ol>
Wheel is noisy.	<ol style="list-style-type: none"> <li>1. Wheel bearing is worn out.</li> <li>2. V-belt is too tight (lower wheel).</li> </ol>	<ol style="list-style-type: none"> <li>1. Replace wheel bearing.</li> <li>2. Check/re-tension the V-belt (<b>Page 41</b>).</li> </ol>
Blade does not track consistently, correctly, or at all.	<ol style="list-style-type: none"> <li>1. Rubber tires on wheels are worn out.</li> </ol>	<ol style="list-style-type: none"> <li>1. Redress the rubber tires on the wheels (<b>Page 37</b>).</li> </ol>



# V-Belt Pulley Alignment

The correct alignment of the motor and lower wheel pulleys helps to ensure correct and even tension of the V-belts, proper power transmission, and reduced V-belt heat and wear during operation.

Remove the rear motor access panel, and use a straightedge across both pulleys, as shown in **Figure 47**, to check the pulley alignment.



**Figure 47.** Checking pulley alignment.

If necessary, use a 19mm wrench to loosen the two hex nuts securing the wheel pulley to its shaft, align the wheel pulley with the motor pulley, then re-tighten the hex bolts.

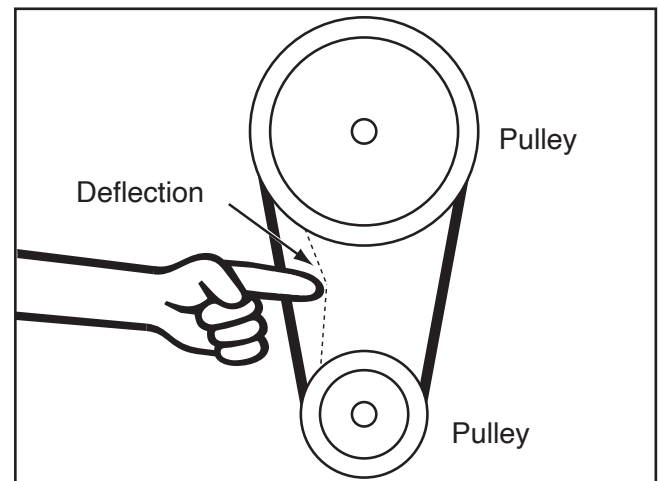
# Tensioning/ Replacing V-Belts

To ensure optimum power transfer from the motor to the blade without slipping, the V-belts must be in good condition and operate under proper tension. Check V-belt tension at least every three months—more often if the bandsaw is used daily. V-belts stretch with use and must be periodically re-tensioned.

Replace the V-belts as a matched set if they are cracked, frayed, or excessively worn.

## To check/tension/replace the V-belts:

1. DISCONNECT BANDSAW FROM POWER!
2. Remove the rear motor access panel.
3. Make sure the motor and lower wheel pulleys are correctly aligned.
4. Push the center of each V-belt as illustrated in **Figure 48**, using moderate force. When tensioned correctly, the deflection should be about  $\frac{3}{4}$ ".



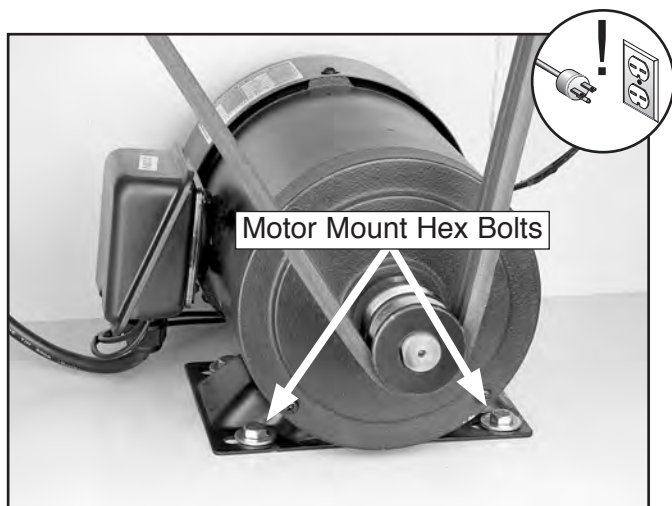
**Figure 48.** Checking for correct V-belt tension.



—If the deflection is correct and the V-belts are in good condition, no further action is required. Replace the rear motor access panel.

—If the deflection is more than or less than  $\frac{1}{4}$ " or the V-belts need to be replaced, then continue to **Step 5**.

5. Use a 12mm wrench to loosen the four motor mount hex bolts (see **Figure 49**).



**Figure 49.** Motor mount hex bolts.

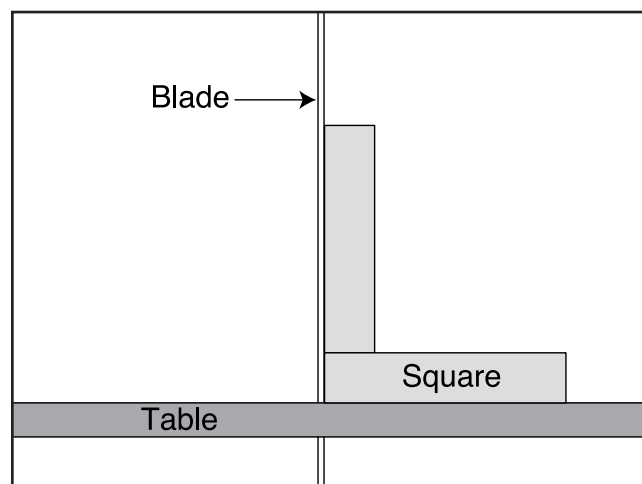
6. If it is necessary to replace the V-belts, slide the motor toward the wheel pulley to relieve the tension, then replace the V-belts with a new matched set.
7. Position the motor to adjust the V-belt tension until they have the correct deflection, then re-tighten the hex bolts.

## Aligning Table To Blade

To ensure the angle accuracy of the cut, the table must be  $90^\circ$  to the blade from front-to-back and side-to-side. If the table is not square to the blade, it needs to be adjusted.

**To adjust the table square to the blade:**

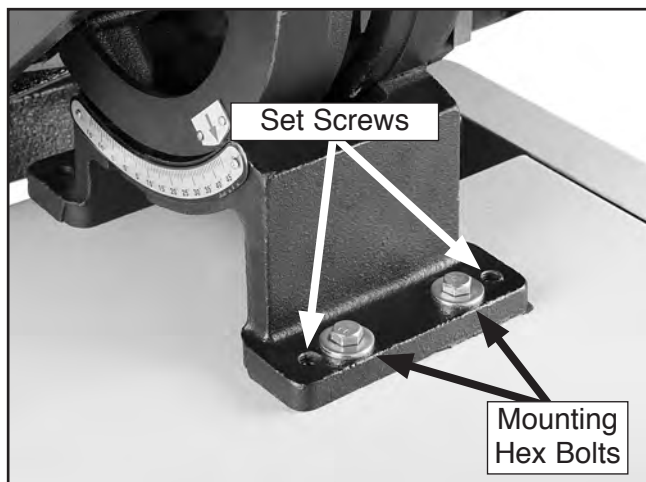
1. DISCONNECT BANDSAW FROM POWER!
2. Make sure the blade is properly tensioned (**Page 29**).
3. Set the angle of the table to "0".
4. Use a square to check table alignment with the blade, as shown in **Figure 50**.



**Figure 50.** Checking table alignment with the blade.



- Use a 12mm wrench to loosen the table mounting hex bolts (see **Figure 51**).



**Figure 51.** Table mounting hex bolts and adjusting set screws.

- Use a 5mm hex wrench to adjust the set screws so that the table is square to the blade front-to-back and side-to-side.

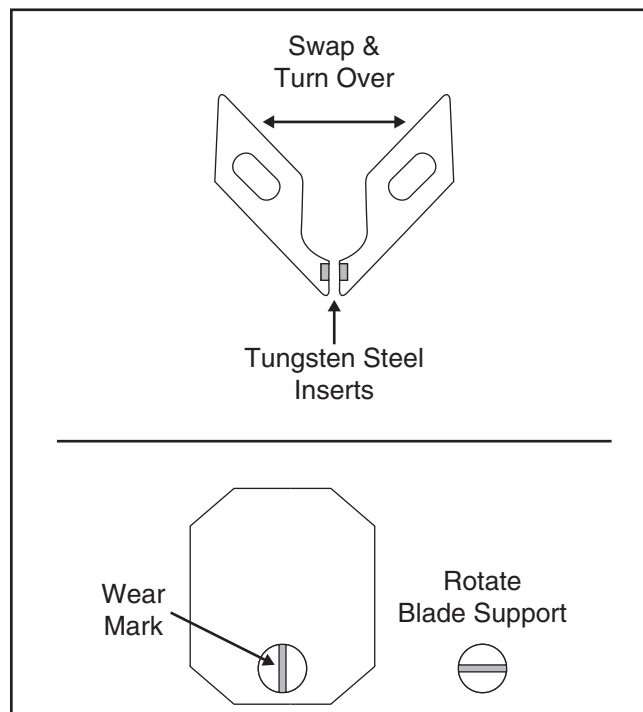
**Note:** Make small adjustments to the set screws, then recheck the alignment of the table with the blade.

- When the table is 90° to the blade from front-to-back and side-to-side, re-tighten the mounting hex bolts to secure the table alignment.

## Blade Guides/ Support

The inserts in the face of the blade guides and the blade support are made of tungsten steel.

With use, the front of the blade guide inserts will wear and it may become difficult to properly adjust the guides to the blade (refer to **Adjusting Blade Guides on Page 31**). If this is the case, swap and turn over the blade guides so that the inserts are reversed relative to the blade (see **Figure 52**).



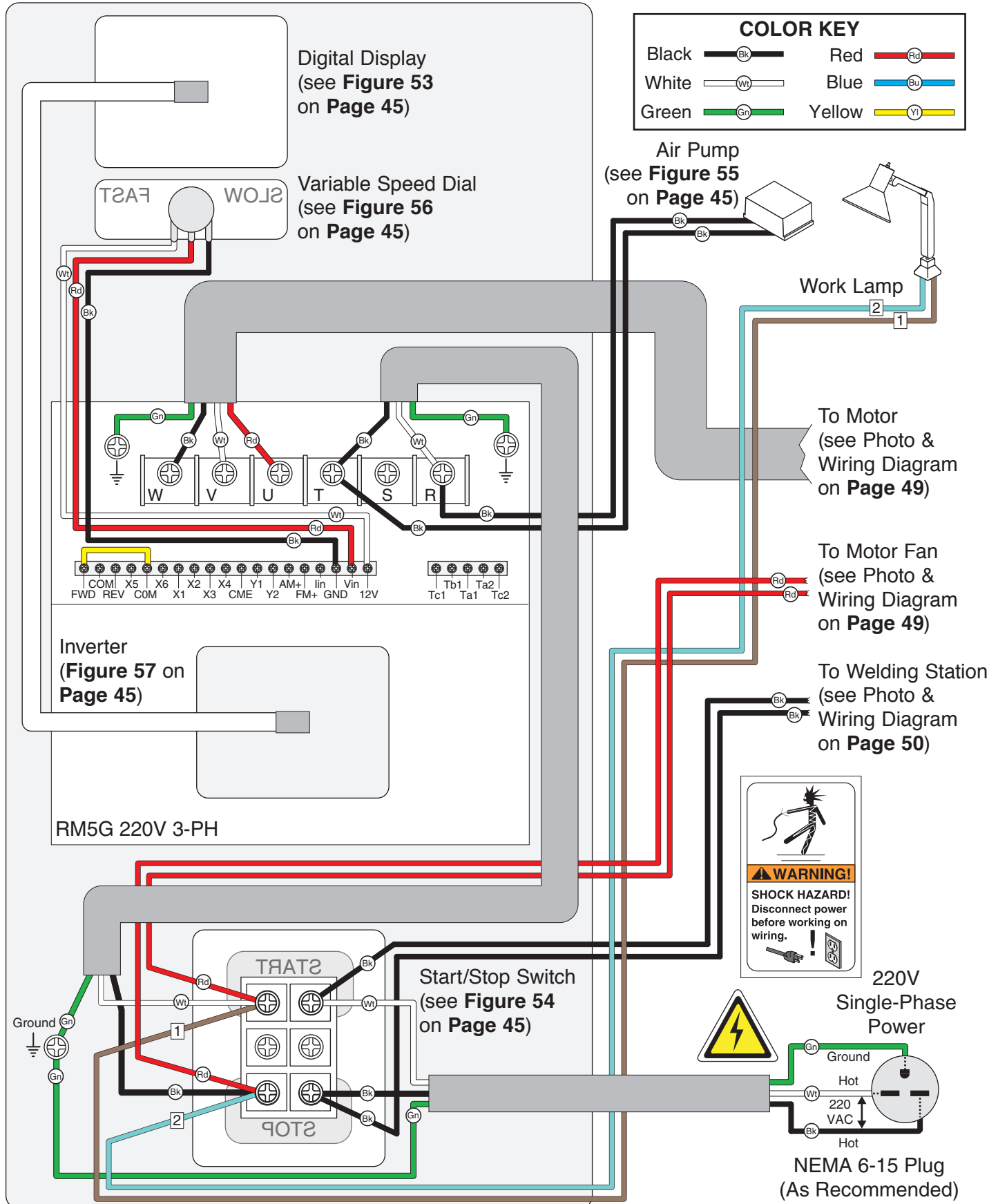
**Figure 52.** Blade guide and support orientation.

As the blade is deflected back into the blade support during operation, a groove will eventually wear into the blade support. As this groove becomes deeper, it can affect the accuracy of the cut. When this happens, loosen the blade support cap screw and rotate the blade support, as shown in **Figure 52**.

**Note:** Make sure to re-adjust the blade guides and support as directed in **Adjusting Blade Guides on Page 31** after making these changes.

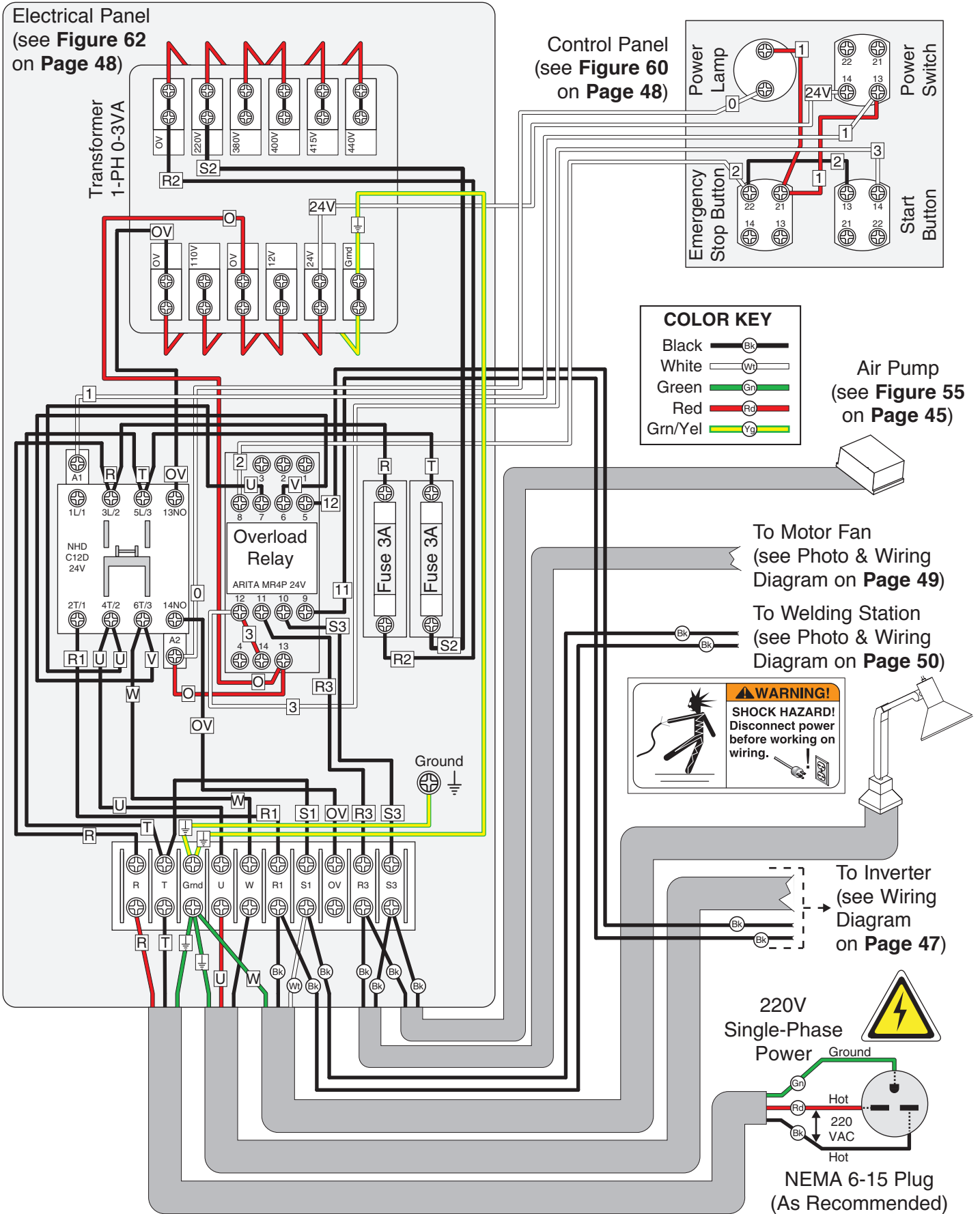


# G8144Z/G8145Z Control Panel & Inverter Wiring Diagram

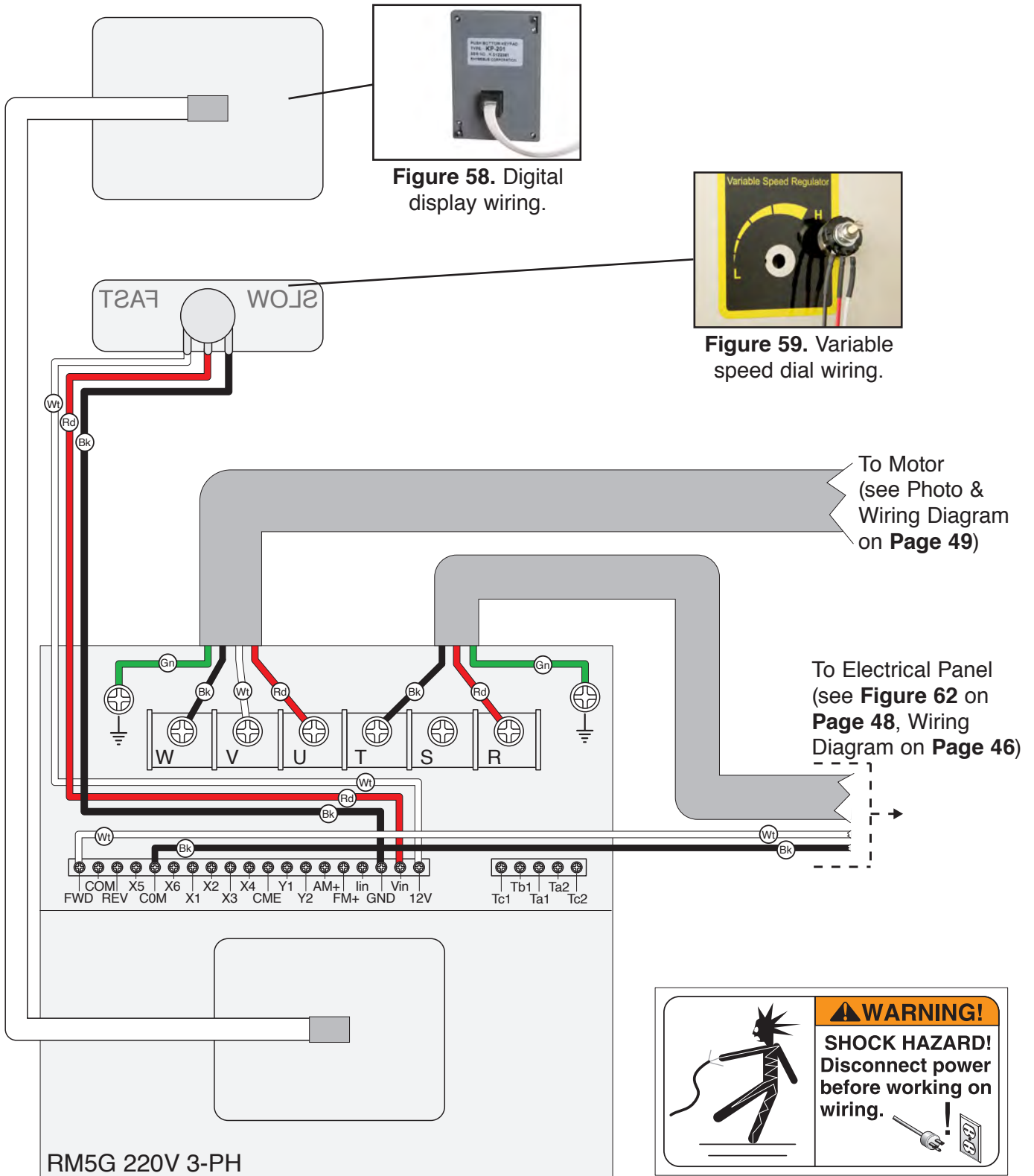




# G8146Z Electrical & Control Wiring Diagram



# G8146Z Inverter Wiring Diagram



**Figure 58.** Digital display wiring.




**Figure 59.** Variable speed dial wiring.

To Motor  
(see Photo & Wiring Diagram on Page 49)

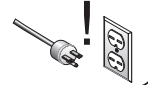
To Electrical Panel  
(see Figure 62 on Page 48, Wiring Diagram on Page 46)

Inverter  
(see Figure 61 on Page 48)



**⚠ WARNING!**

**SHOCK HAZARD!**  
Disconnect power before working on wiring.





# G8146Z Electrical Components

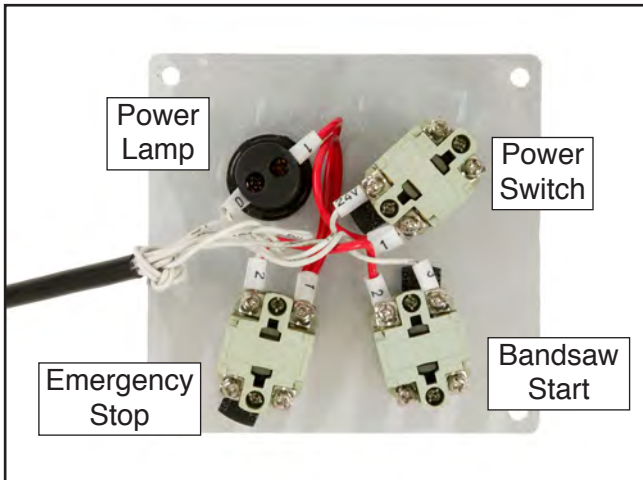


Figure 60. Control panel wiring (see wiring diagram on Page 46).



Figure 61. Inverter/Controller box wiring (see wiring diagram on Page 47).

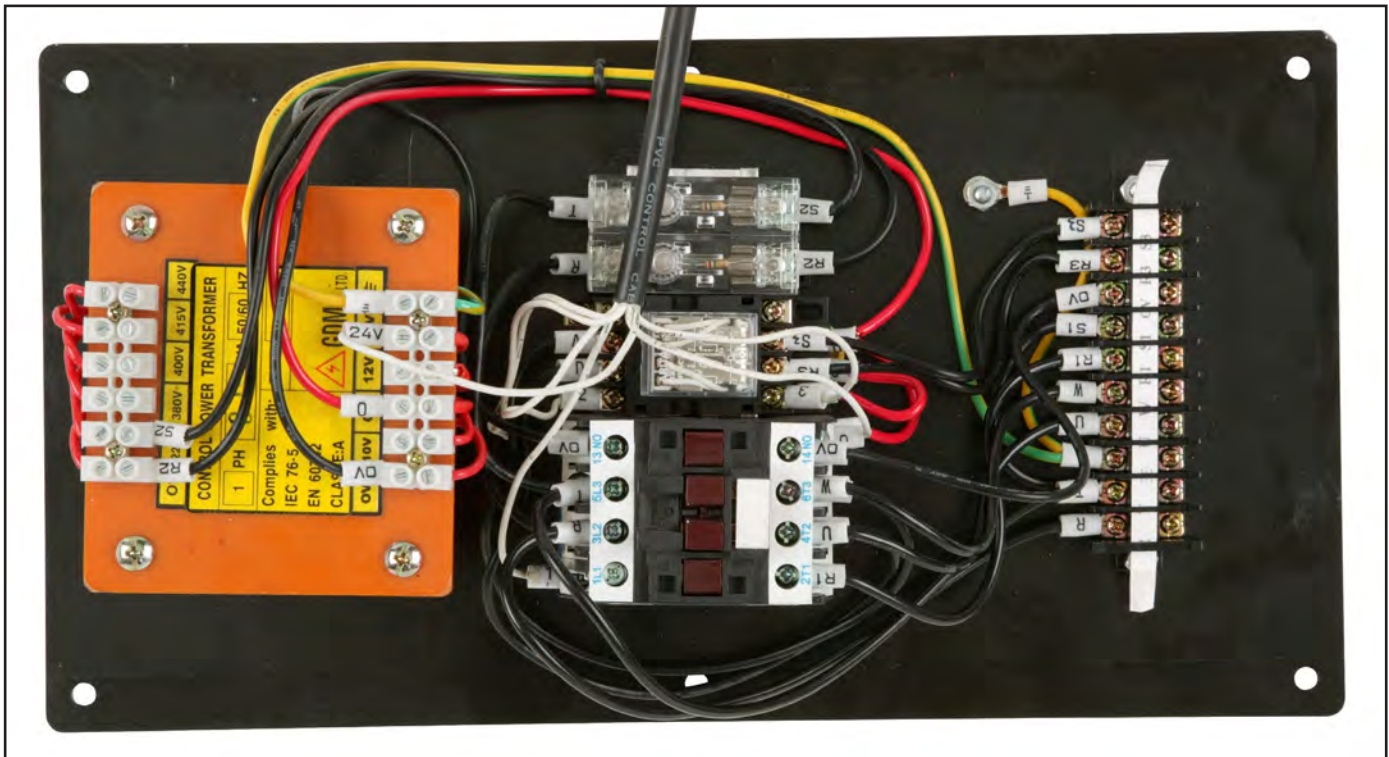


Figure 62. Main electrical wiring (see wiring diagram on Page 46).



# Motor Wiring Diagram

COLOR KEY	
Black	
White	
Green	
Red	



**⚠ WARNING!**

**SHOCK HAZARD!**  
Disconnect power before working on wiring.



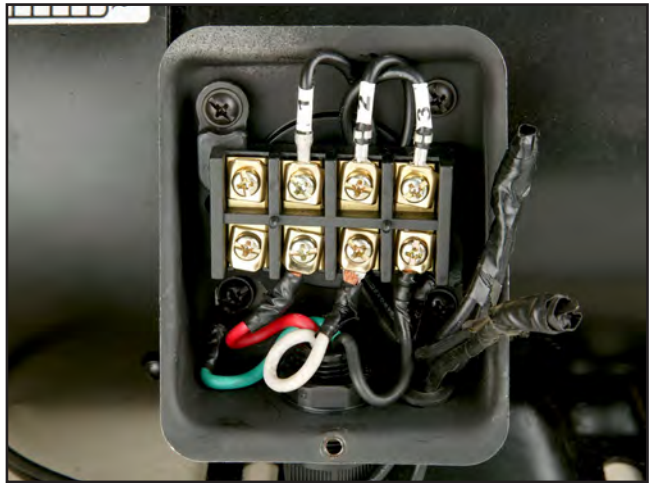
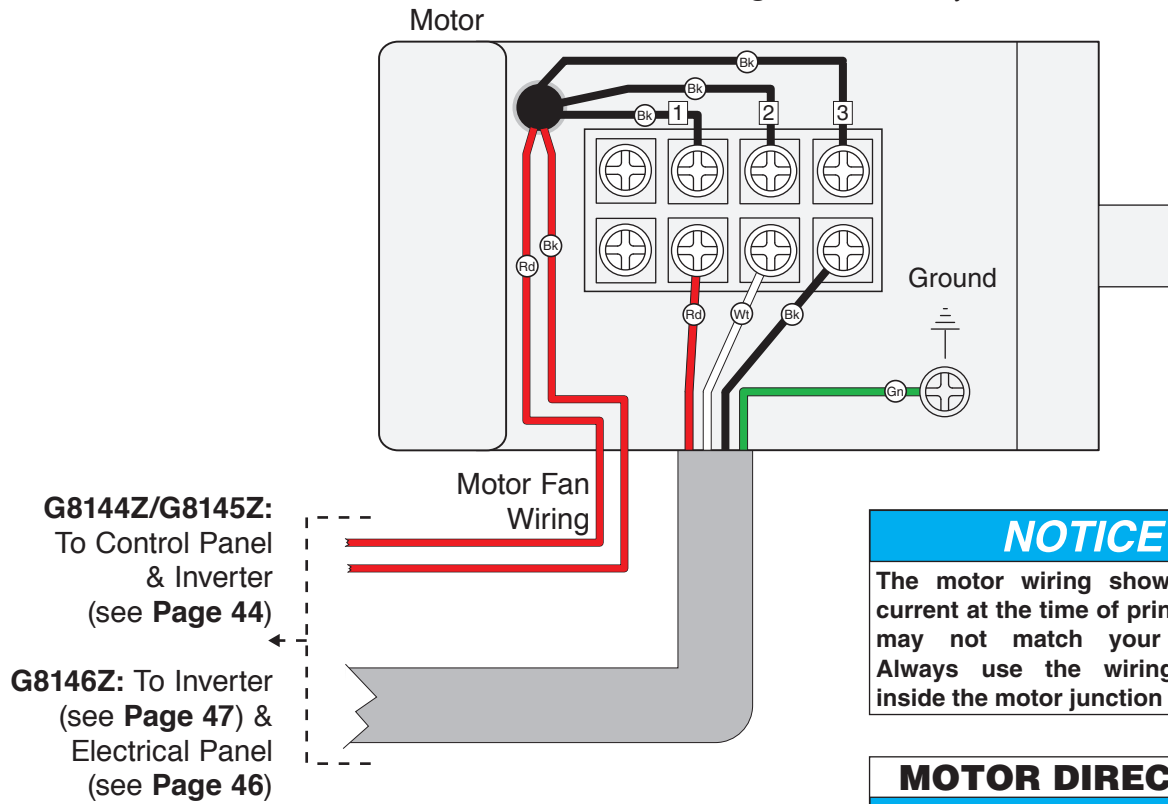


Figure 63. Motor junction box wiring.



**G8144Z/G8145Z:**  
To Control Panel & Inverter  
(see Page 44)

**G8146Z:** To Inverter  
(see Page 47) & Electrical Panel  
(see Page 46)

**NOTICE**

The motor wiring shown here is current at the time of printing, but it may not match your machine. Always use the wiring diagram inside the motor junction box.

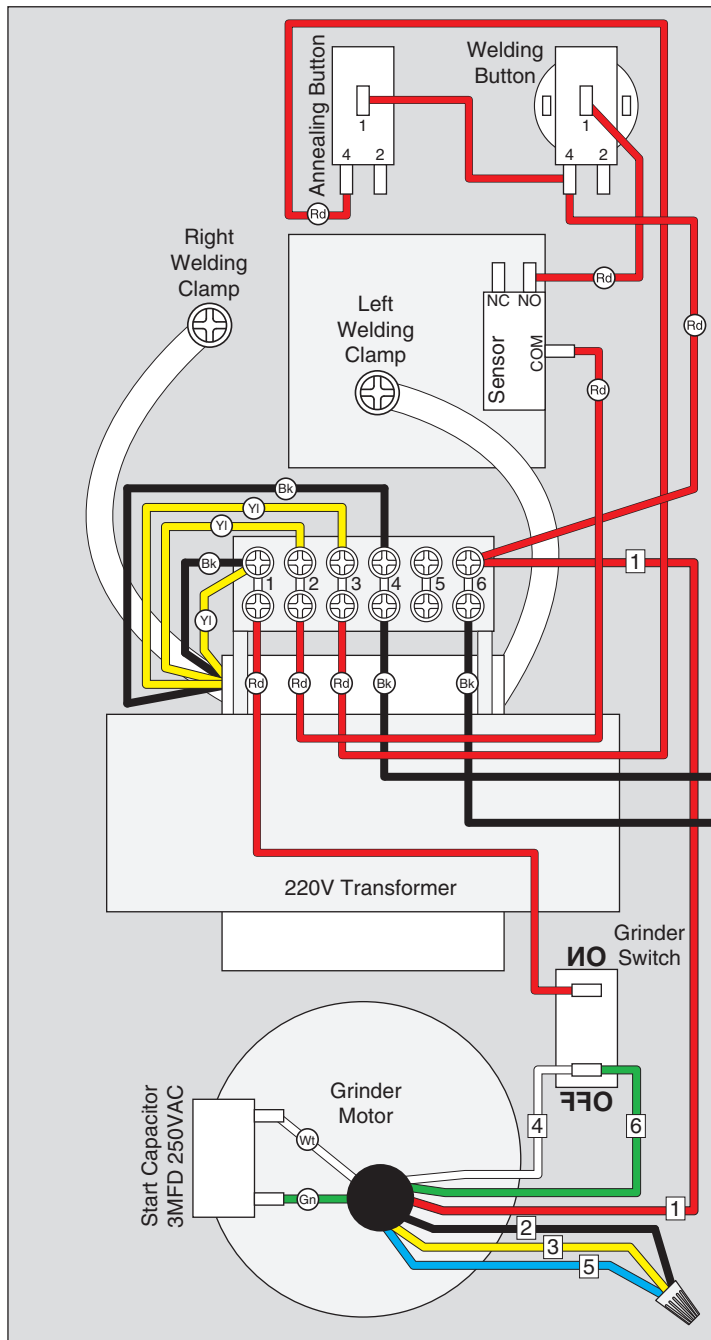
**MOTOR DIRECTION**

**NOTICE**

If motor rotates in opposite direction, swap any two power source wires at the incoming terminals.



# Welding Station Wiring Diagram



**COLOR KEY**

Black		Red	
White		Blue	
Green		Yellow	

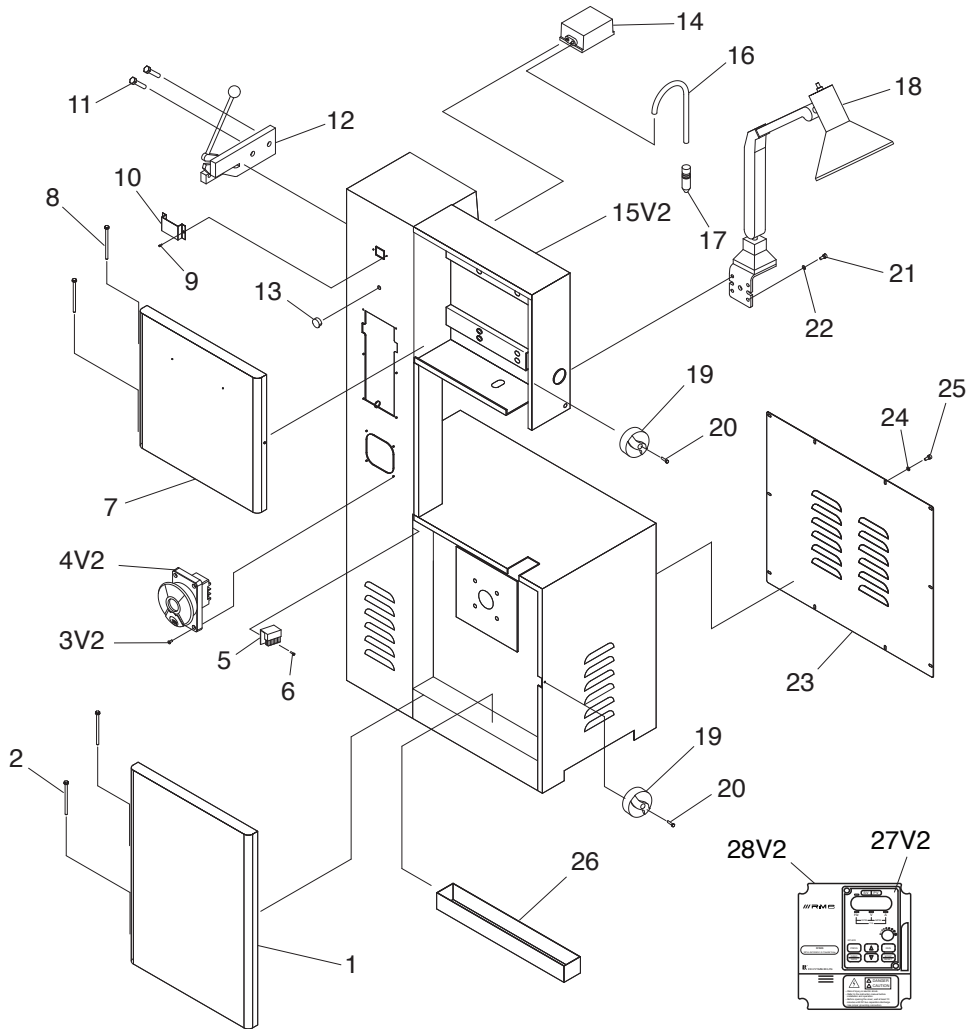
**G8144Z/G8145Z:**  
To Start/Stop Switch  
(see Page 44)

**G8146Z:**  
To Electrical Panel  
(see Page 46)



# SECTION 8: PARTS

## G8144Z Cabinet Breakdown & Parts List

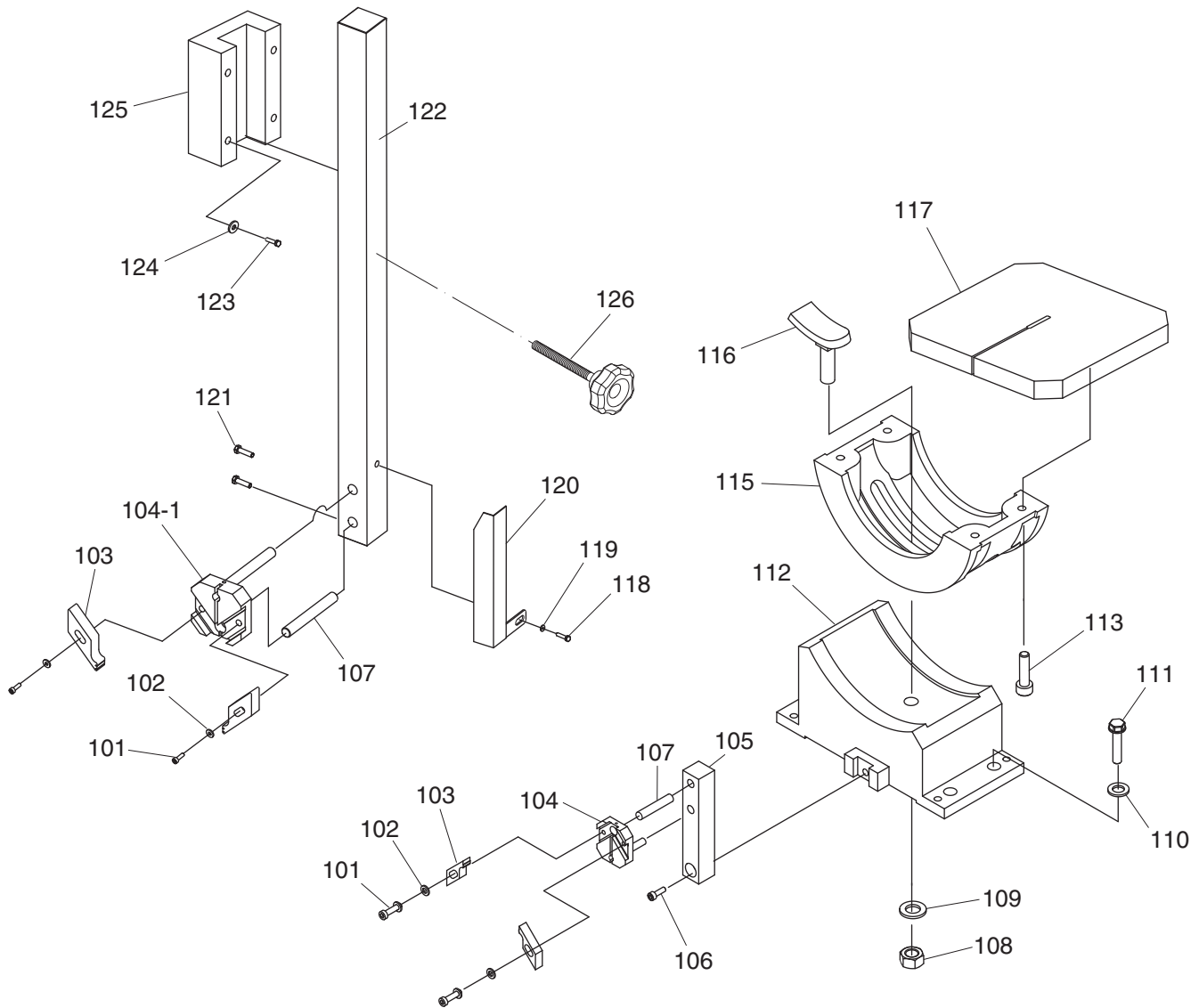


REF	PART #	DESCRIPTION
1	P8144Z001	WHEEL DOOR LOWER
2	P8144Z002	HINGE PIN LOWER
3	PS05M	PHLP HD SCR M5-.8 X 8
4	P8144Z004	ON/OFF SWITCH W/PADDLE
5	P8144Z005	BLADE CLEANING BRUSH
6	PS47M	PHLP HD SCR M6-1 X 25
7	P8144Z007	WHEEL DOOR UPPER
8	P8144Z002	HINGE PIN UPPER
9	PS05M	PHLP HD SCR M5-.8 X 8
10	P8144Z010	DIGITAL DISPLAY BRACKET
11	PSB11M	CAP SCREW M8-1.25 X 16
12	P8144Z012	BLADE SHEAR
13	P8144Z013	VARIABLE SPEED DIAL
14	P8144Z014	AIR PUMP

REF	PART #	DESCRIPTION
15	P8144Z015	BANDSAW CABINET
16	P8144Z016	AIR HOSE 4X6MM
17	P8144Z017	AIR NOZZLE
18	P8144Z018	WORK LAMP 220V
19	P8144Z019	DOOR KNOB
20	PS47M	PHLP HD SCR M6-1 X 25
21	PSB28M	CAP SCREW M6-1 X 15
22	PW03M	FLAT WASHER 6MM
23	P8144Z023	MOTOR ACCESS PANEL
24	PW03M	FLAT WASHER 6MM
25	PS68M	PHLP HD SCR M6-1 X 10
26	P8144Z026	CHIP PAN
27	P8144Z027	DIGITAL DISPLAY
28	P8144Z028	INVERTER RM5G 1HP 220V 3PH



# G8144Z Table & Guides Breakdown & Parts List

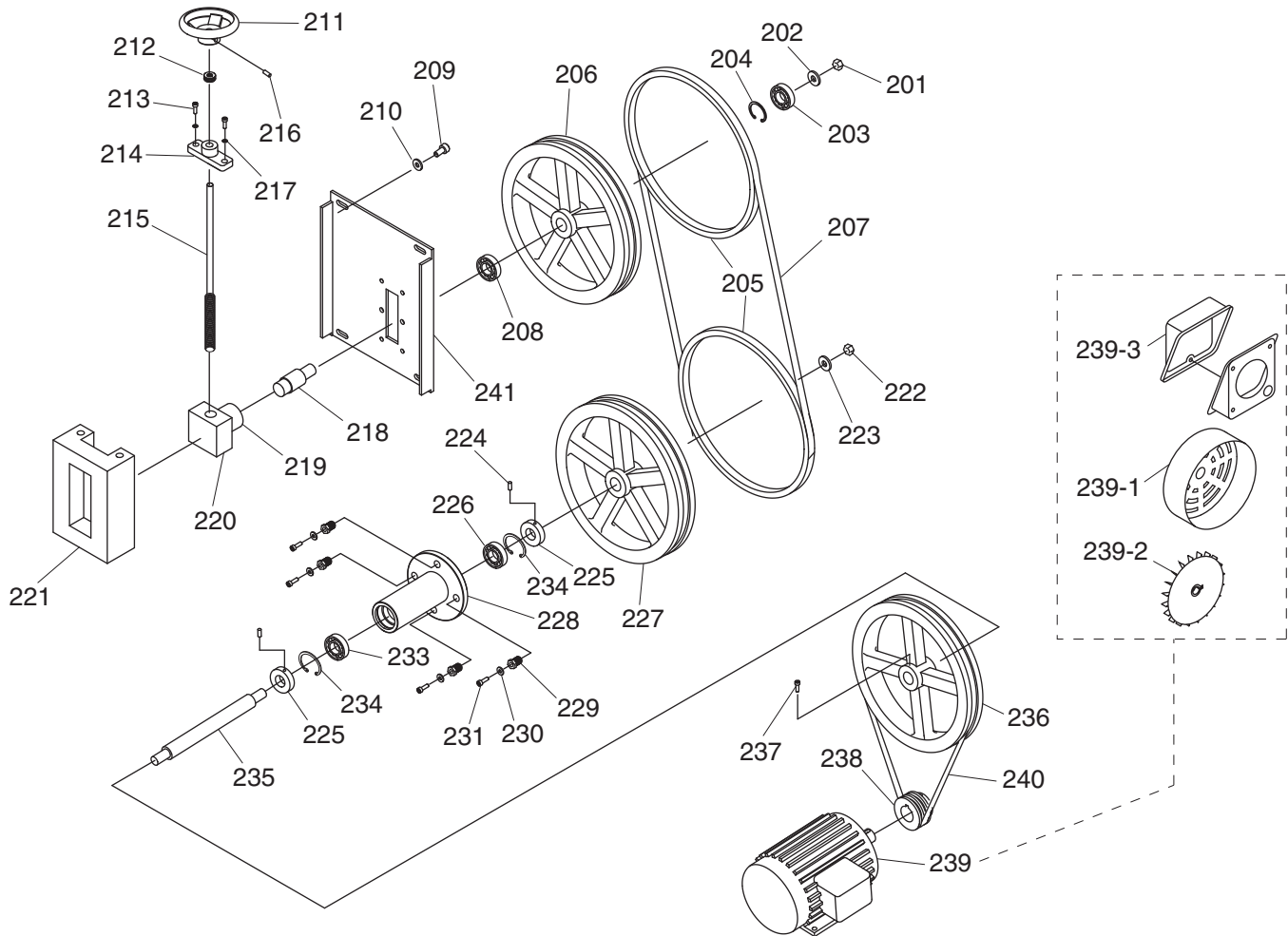


REF	PART #	DESCRIPTION
101	PSB15M	CAP SCREW M5-.8 X 20
102	PW02M	FLAT WASHER 5MM
103	P8144Z103	BLADE GUIDE
104	P8144Z104	BLADE GUIDE BRACKET LOWER
104-1	P8144Z104-1	BLADE GUIDE BRACKET UPPER
105	P8144Z105	GUIDE POST LOWER
106	PSB64M	CAP SCREW M10-1.5 X 25
107	P8144Z107	BLADE SUPPORT
108	PN04	HEX NUT 5/8-11
109	PW14	FLAT WASHER 5/8
110	PW01M	FLAT WASHER 8MM
111	PB26M	HEX BOLT M8-1.25 X 30
112	P8144Z112	TRUNNION BASE

REF	PART #	DESCRIPTION
113	PSB31M	CAP SCREW M8-1.25 X 25
115	P8144Z115	TRUNNION
116	P8144Z116	TABLE TILT LOCK 5/8-11 X 2
117	P8144Z117	TABLE
118	PSB11M	CAP SCREW M8-1.25 X 16
119	PW01M	FLAT WASHER 8MM
120	P8144Z120	BLADE GUARD
121	PSB11M	CAP SCREW M8-1.25 X 16
122	P8144Z122	GUIDE POST UPPER
123	PSB13M	CAP SCREW M8-1.25 X 30
124	PW01M	FLAT WASHER 8MM
125	P8144Z125	GUIDE POST WAY
126	P8144Z126	KNOB M12-1.75 X 70 6-LOBES



# G8144Z Drive System Breakdown

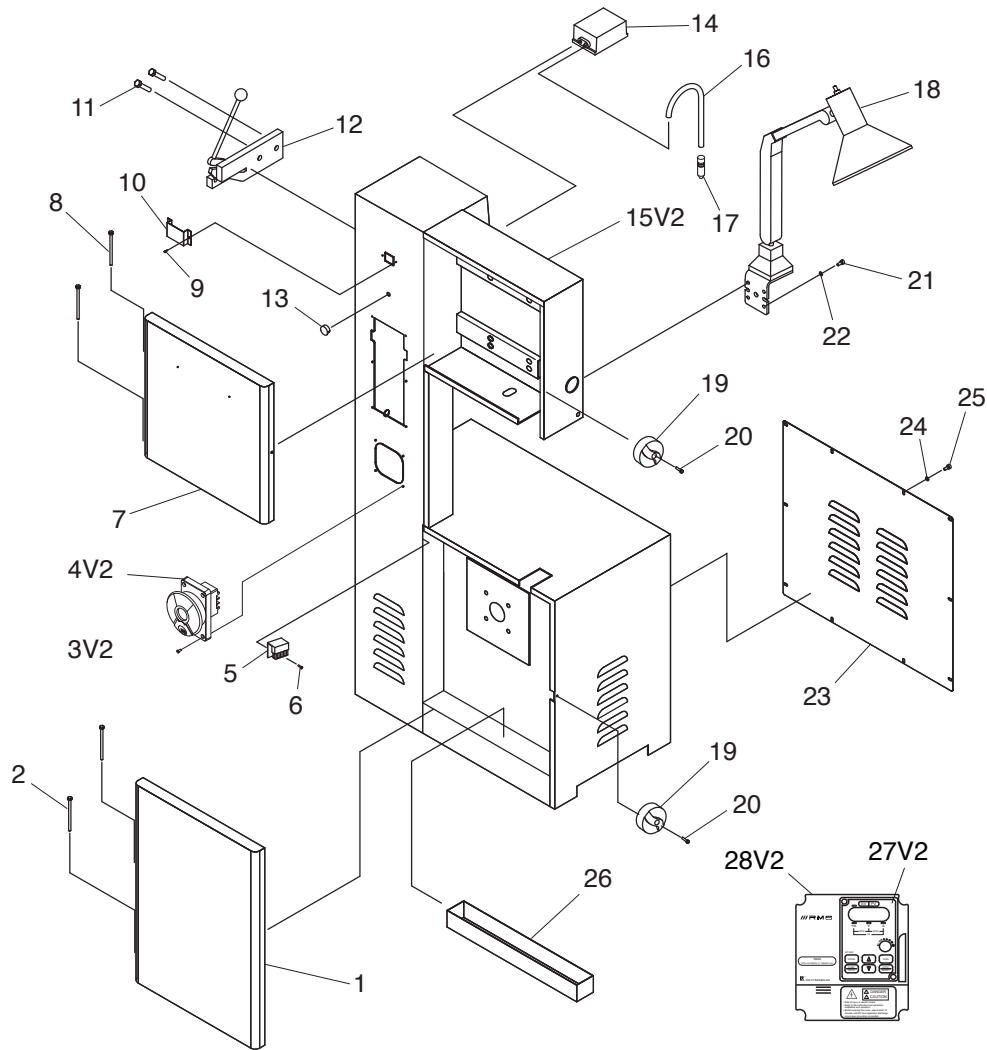


REF	PART #	DESCRIPTION
201	PN01	HEX NUT 1/2-20
202	PLW07	LOCK WASHER 1/2
203	P6203	BALL BEARING 6203ZZ
204	PR21M	INT RETAINING RING 35MM
205	P8144Z205	WHEEL TIRE
206	P8144Z206	WHEEL UPPER
207	P8144Z207	BANDSAW BLADE 1/4"W STANDARD
208	P6203	BALL BEARING 6203ZZ
209	PB02M	HEX BOLT M6-1 X 12
210	PW03M	FLAT WASHER 6MM
211	P8144Z211	BLADE TENSIONING HANDWHEEL
212	P8144Z212	BUSHING
213	PSB13M	CAP SCREW M8-1.25 X 30
214	P8144Z214	LEADSCREW BRACKET
215	P8144Z215	LEADSCREW 3/4-6 X 7
216	PSS09M	SET SCREW M8-1.25 X 20
217	PLW04M	LOCK WASHER 8MM
218	P8144Z218	UPPER WHEEL SHAFT
219	P8144Z219	BUSHING
220	P8144Z220	LEADSCREW NUT 3/4-6
221	P8144Z221	TENSIONING WAY
222	PN09	HEX NUT 5/8-18

REF	PART #	DESCRIPTION
223	PLW06	LOCK WASHER 5/8
224	PSS20M	SET SCREW M8-1.25 X 8
225	P8144Z225	COLLAR
226	P6203	BALL BEARING 6203ZZ
227	P8144Z227	WHEEL LOWER
228	P8144Z228	BEARING HOUSING
229	P8144Z229	SPECIAL SCREW 3/4-16
230	PLW06M	LOCK WASHER 10MM
231	PSB143M	CAP SCREW M10-1.5 X 50
233	P6205	BALL BEARING 6205ZZ
234	PR26M	INT RETAINING RING 52MM
235	P8144Z235	LOWER WHEEL SHAFT
236	P8144Z236	WHEEL PULLEY
237	PSB36M	CAP SCREW M12-1.75 X 25
238	P8144Z238	MOTOR PULLEY
239	P8144Z239	MOTOR 1HP 220V 3PH
239-1	P8144Z239-1	MOTOR FAN COVER
239-2	P8144Z239-2	MOTOR FAN
239-3	P8144Z239-3	MOTOR WIRING JUNCTION BOX
240	PVA57	V-BELT A-57 4L570
241	P8144Z241	TENSIONING PANEL



# G8145Z Cabinet Breakdown & Parts List

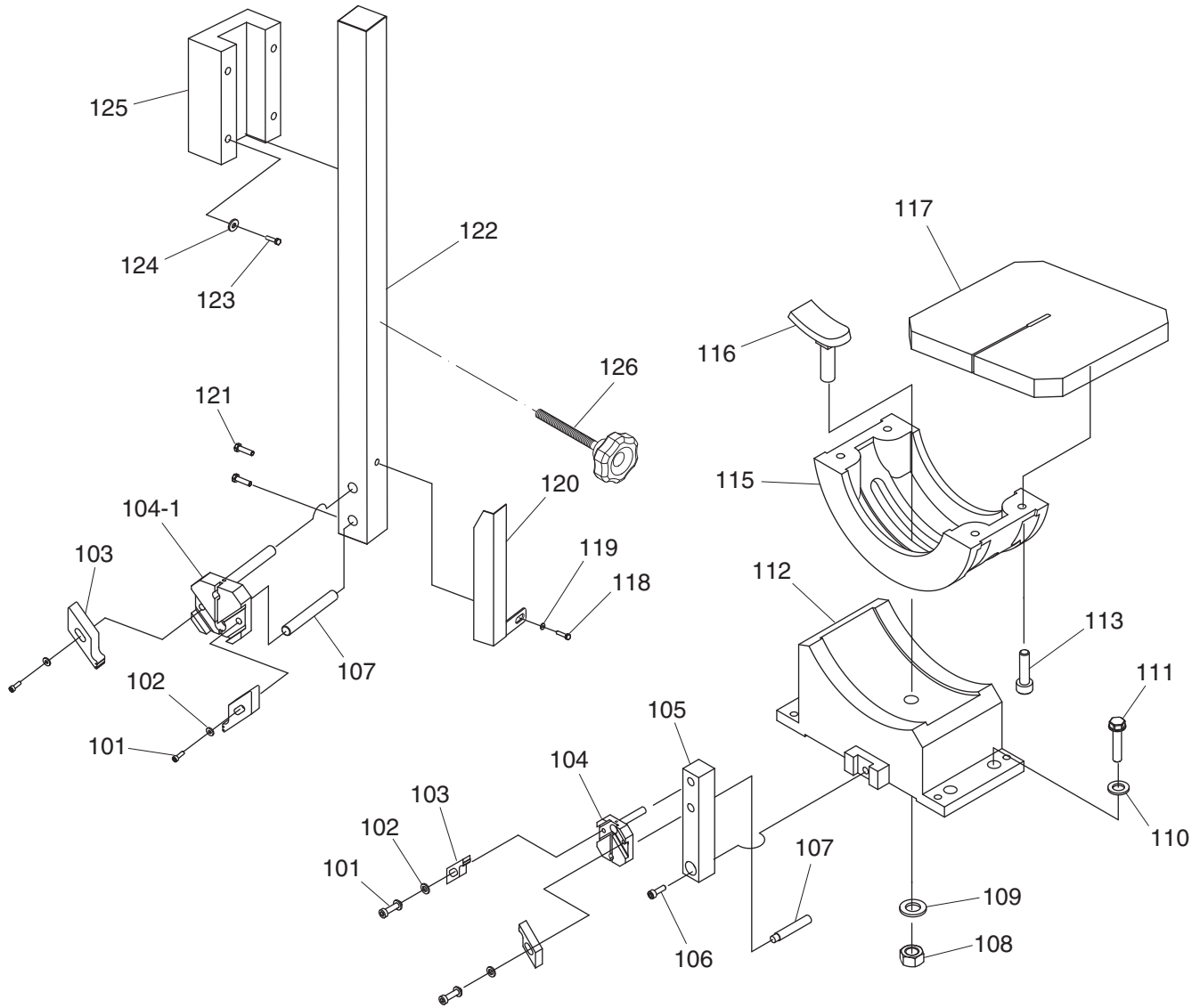


REF	PART #	DESCRIPTION
1	P8145Z001	WHEEL DOOR LOWER
2	P8144Z002	HINGE PIN LOWER
3	PS05M	PHLP HD SCR M5-.8 X 8
4	P8145Z004	ON/OFF SWITCH W/PADDLE
5	P8144Z005	BLADE CLEANING BRUSH
6	PS47M	PHLP HD SCR M6-1 X 25
7	P8145Z007	WHEEL DOOR UPPER
8	P8144Z002	HINGE PIN UPPER
9	PS05M	PHLP HD SCR M5-.8 X 8
10	P8144Z010	DIGITAL DISPLAY BRACKET
11	PSB11M	CAP SCREW M8-1.25 X 16
12	P8144Z012	BLADE SHEAR
13	P8144Z013	VARIABLE SPEED DIAL
14	P8144Z014	AIR PUMP

REF	PART #	DESCRIPTION
15	P8145Z015	BANDSAW CABINET
16	P8144Z016	AIR HOSE 4X6MM
17	P8144Z017	AIR NOZZLE
18	P8144Z018	WORK LAMP 220V
19	P8144Z019	DOOR KNOB
20	PS47M	PHLP HD SCR M6-1 X 25
21	PSB28M	CAP SCREW M6-1 X 15
22	PW03M	FLAT WASHER 6MM
23	P8145Z023	MOTOR ACCESS PANEL
24	PW03M	FLAT WASHER 6MM
25	PS68M	PHLP HD SCR M6-1 X 10
26	P8145Z026	CHIP PAN
27	P8144Z027	DIGITAL DISPLAY
28	P8145Z028	INVERTER RM5G 1-1/2HP 220V 3PH



# G8145Z Table & Guides Breakdown & Parts List



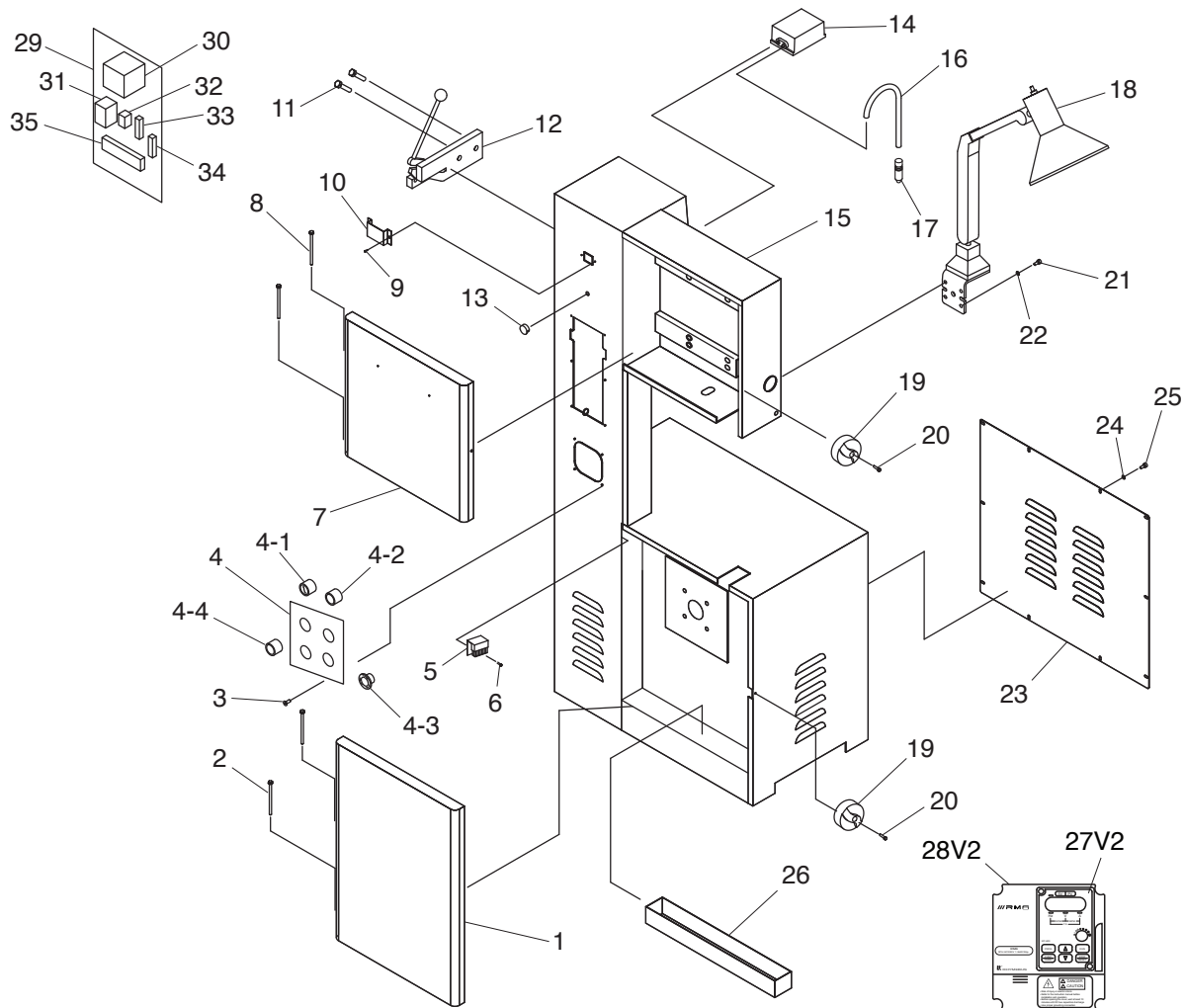
REF	PART #	DESCRIPTION
101	PSB15M	CAP SCREW M5-.8 X 20
102	PW02M	FLAT WASHER 5MM
103	P8144Z103	BLADE GUIDE
104	P8144Z104	BLADE GUIDE BRACKET LOWER
104-1	P8144Z104-1	BLADE GUIDE BRACKET UPPER
105	P8144Z105	GUIDE POST LOWER
106	PSB64M	CAP SCREW M10-1.5 X 25
107	P8145Z107	BLADE SUPPORT
108	PN04	HEX NUT 5/8-11
109	PLW06	LOCK WASHER 5/8
110	PW01M	FLAT WASHER 8MM
111	PB26M	HEX BOLT M8-1.25 X 30
112	P8144Z112	TRUNNION BASE

REF	PART #	DESCRIPTION
113	PSB31M	CAP SCREW M8-1.25 X 25
115	P8144Z115	TRUNNION
116	P8144Z116	TABLE TILT LOCK 5/8-11 X 2
117	P8145Z117	TABLE
118	PSB11M	CAP SCREW M8-1.25 X 16
119	PW01M	FLAT WASHER 8MM
120	P8145Z120	BLADE GUARD
121	PSB11M	CAP SCREW M8-1.25 X 16
122	P8145Z122	GUIDE POST UPPER
123	PSB13M	CAP SCREW M8-1.25 X 30
124	PW01M	FLAT WASHER 8MM
125	P8145Z125	GUIDE POST WAY
126	P8144Z126	KNOB M12-1.75 X 70 6-LOBES





# G8146Z Cabinet Breakdown & Parts List

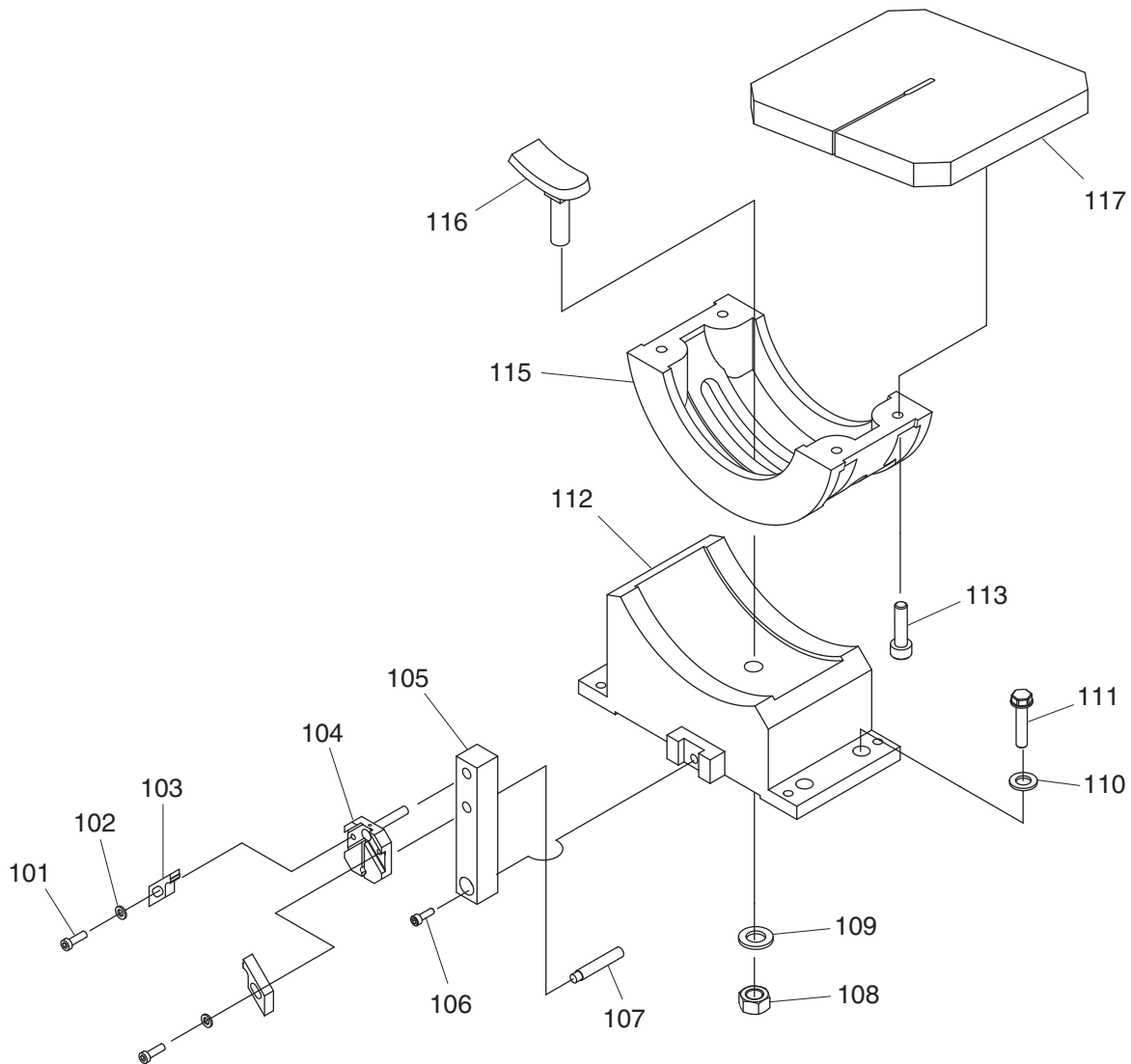


REF	PART #	DESCRIPTION
1	P8146Z001	WHEEL DOOR LOWER
2	P8144Z002	HINGE PIN LOWER
3	PS05M	PHLP HD SCR M5-.8 X 8
4	P8146Z004	CONTROL PANEL
4-1	P8146Z004-1	POWER SWITCH W/KEY
4-2	P8146Z004-2	POWER LAMP
4-3	P8146Z004-3	EMERGENCY STOP BUTTON
4-4	P8146Z004-4	MOTOR ON BUTTON
5	P8144Z005	BLADE CLEANING BRUSH
6	PS22M	PHLP HD SCR M5-.8 X 25
7	P8146Z007	WHEEL DOOR UPPER
8	P8144Z002	HINGE PIN UPPER
9	PS05M	PHLP HD SCR M5-.8 X 8
10	P8144Z010	DIGITAL DISPLAY BRACKET
11	PSB11M	CAP SCREW M8-1.25 X 16
12	P8144Z012	BLADE SHEAR
13	P8144Z013	VARIABLE SPEED DIAL
14	P8144Z014	AIR PUMP
15	P8146Z015	BANDSAW CABINET
16	P8144Z016	AIR HOSE 4X6MM

REF	PART #	DESCRIPTION
17	P8144Z017	AIR NOZZLE
18	P8146Z018	WORK LAMP 220V
19	P8144Z019	DOOR KNOB
20	PS47M	PHLP HD SCR M6-1 X 25
21	PSB28M	CAP SCREW M6-1 X 15
22	PW03M	FLAT WASHER 6MM
23	P8146Z023	MOTOR ACCESS PANEL
24	PW03M	FLAT WASHER 6MM
25	PS68M	PHLP HD SCR M6-1 X 10
26	P8146Z026	CHIP PAN
27	P8144Z027	DIGITAL DISPLAY
28	P8146Z028	INVERTER RM5G 2HP 220V 3PH
29	P8146Z029	CONTROL PANEL
30	P8146Z030	TRANSFORMER 1PH 0-3VA
31	P8146Z031	CONTACTOR NHD C-12D 24V
32	P8146Z032	OL RELAY ARITA MR4P 24V 3-5A
33	P8146Z033	FUSE HOLDER
34	P8146Z034	FUSE 3A
35	P8146Z035	WIRING BLOCK 10-POST



# G8146Z Table & Lower Guide Breakdown & Parts List

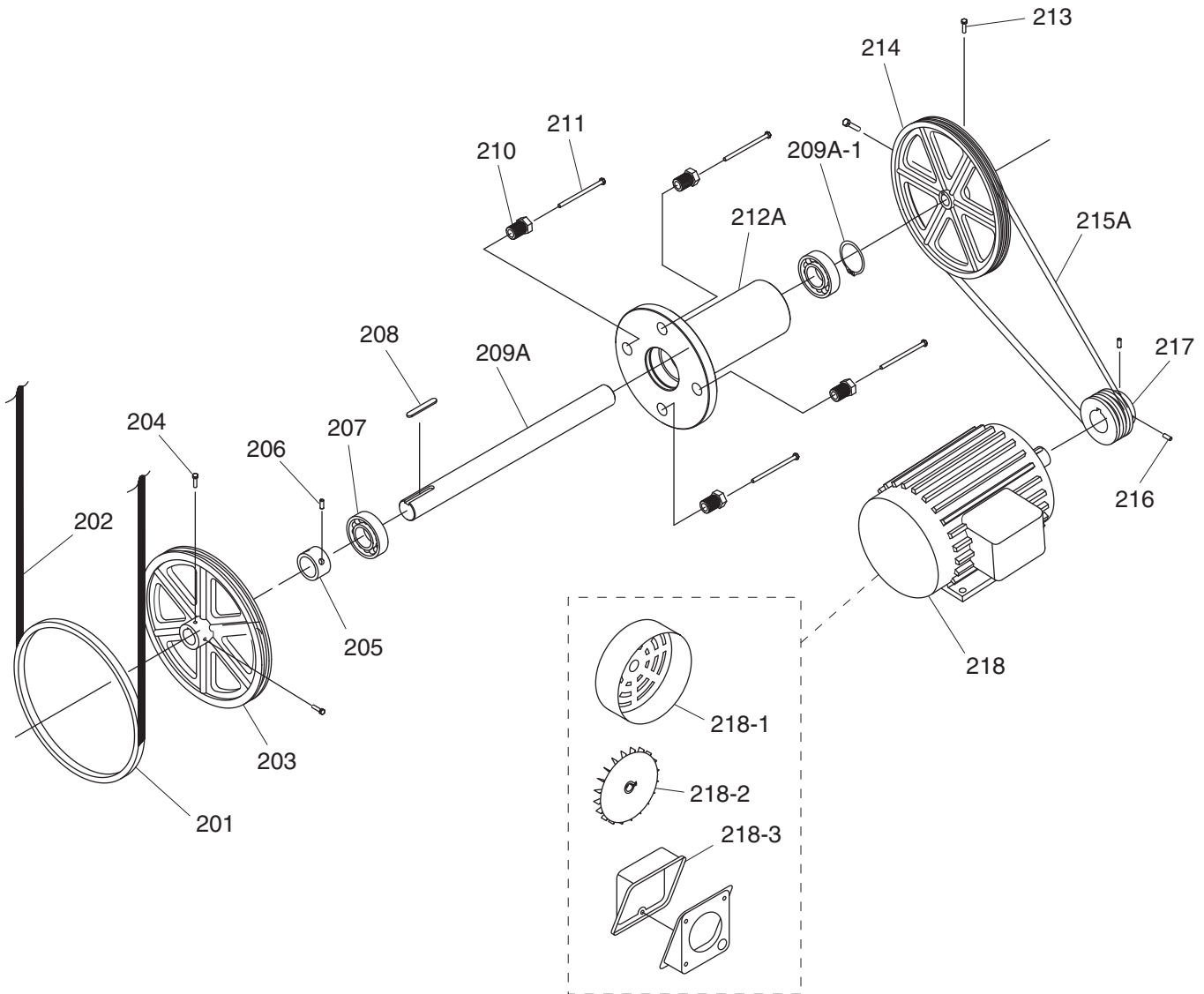


REF	PART #	DESCRIPTION
101	PSB15M	CAP SCREW M5-.8 X 20
102	PLW02M	LOCK WASHER 5MM
103	P8144Z103	BLADE GUIDE
104	P8144Z104	BLADE GUIDE BRACKET LOWER
105	P8146Z105	GUIDE POST LOWER
106	PSB06M	CAP SCREW M6-1 X 25
107	P8144Z107	BLADE SUPPORT
108	PN04	HEX NUT 5/8-11

REF	PART #	DESCRIPTION
109	PLW06	LOCK WASHER 5/8
110	PW01M	FLAT WASHER 8MM
111	PSB14M	CAP SCREW M8-1.25 X 20
112	P8146Z112	TRUNNION BASE
113	PSB14M	CAP SCREW M8-1.25 X 20
115	P8146Z115	TRUNNION
116	P8144Z116	TABLE TILT LOCK 5/8-11 X 2
117	P8146Z117	TABLE



# G8146Z Motor & Lower Wheel Breakdown & Parts List

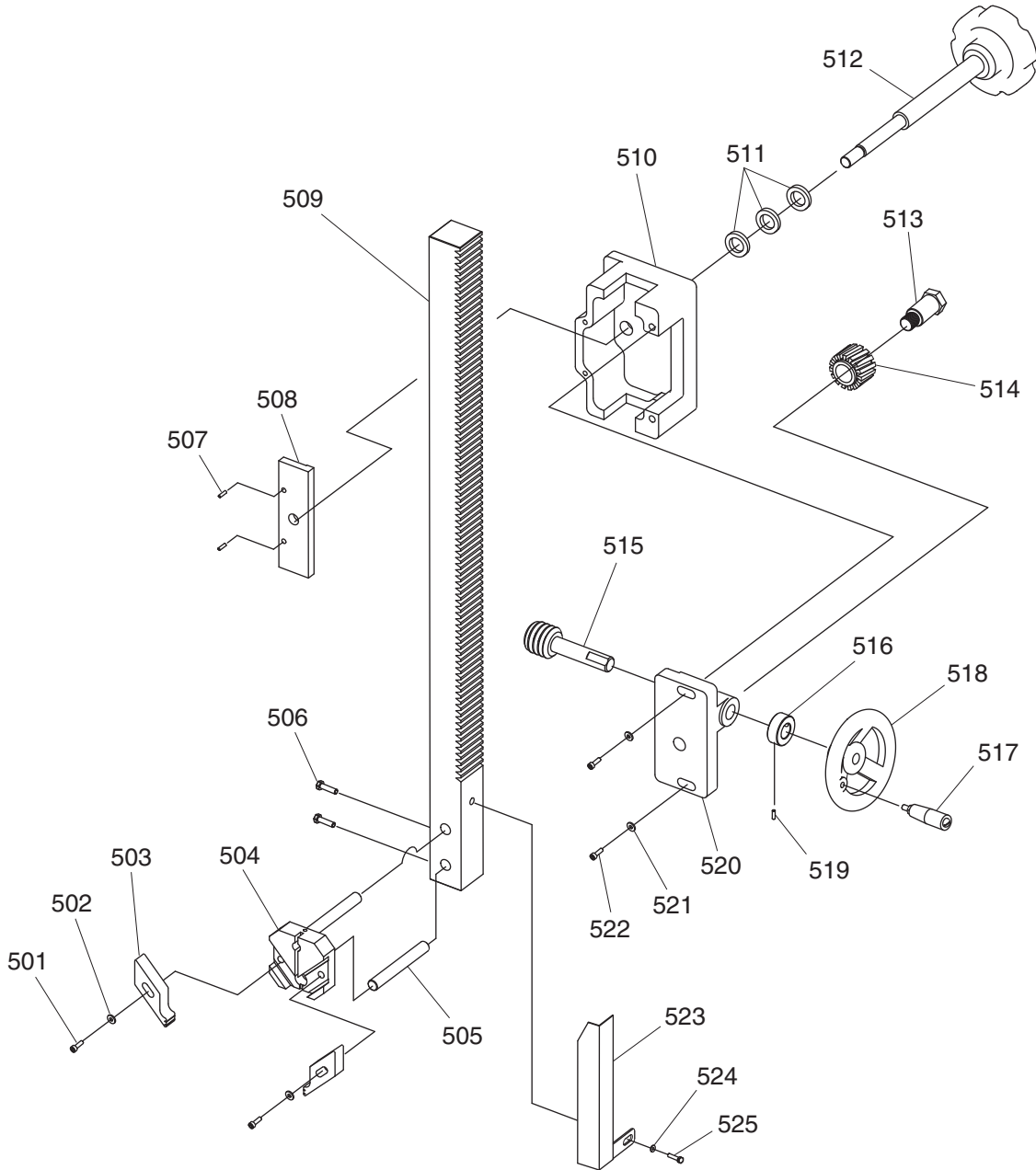


REF	PART #	DESCRIPTION
201	P8146Z201	WHEEL TIRE
202	P8146Z202	BANDSAW BLADE 3/8"W STANDARD
203	P8146Z203	WHEEL LOWER
204	PB170M	HEX BOLT M10-1.5 X 10
205	P8146Z205	COLLAR
206	PSS20M	SET SCREW M8-1.25 X 8
207	P6206	BALL BEARING 6206ZZ
208	PK107M	KEY 8 X 8 X 20
209A	P8146Z209A	LOWER WHEEL SHAFT V2.04.08
209A-1	PR15M	EXT RETAINING RING 30MM
210	P8146Z210	SPECIAL SCREW 3/4-16

REF	PART #	DESCRIPTION
211	PB73M	HEX BOLT M10-1.5 X 50
212A	P8146Z212A	BEARING HOUSING V2.04.08
213	PB25M	HEX BOLT M12-1.75 X 25
214	P8146Z214	WHEEL PULLEY
215A	PVA62	V-BELT A-62 4L620
216	PSS16M	SET SCREW M8-1.25 X 10
217	P8146Z217	MOTOR PULLEY
218	P8146Z218	MOTOR 2HP 220V 3PH
218-1	P8146Z218-1	MOTOR FAN COVER
218-2	P8146Z218-2	MOTOR FAN
218-3	P8146Z218-3	MOTOR WIRING JUNCTION BOX



# G8146Z Guide Post Breakdown & Parts List

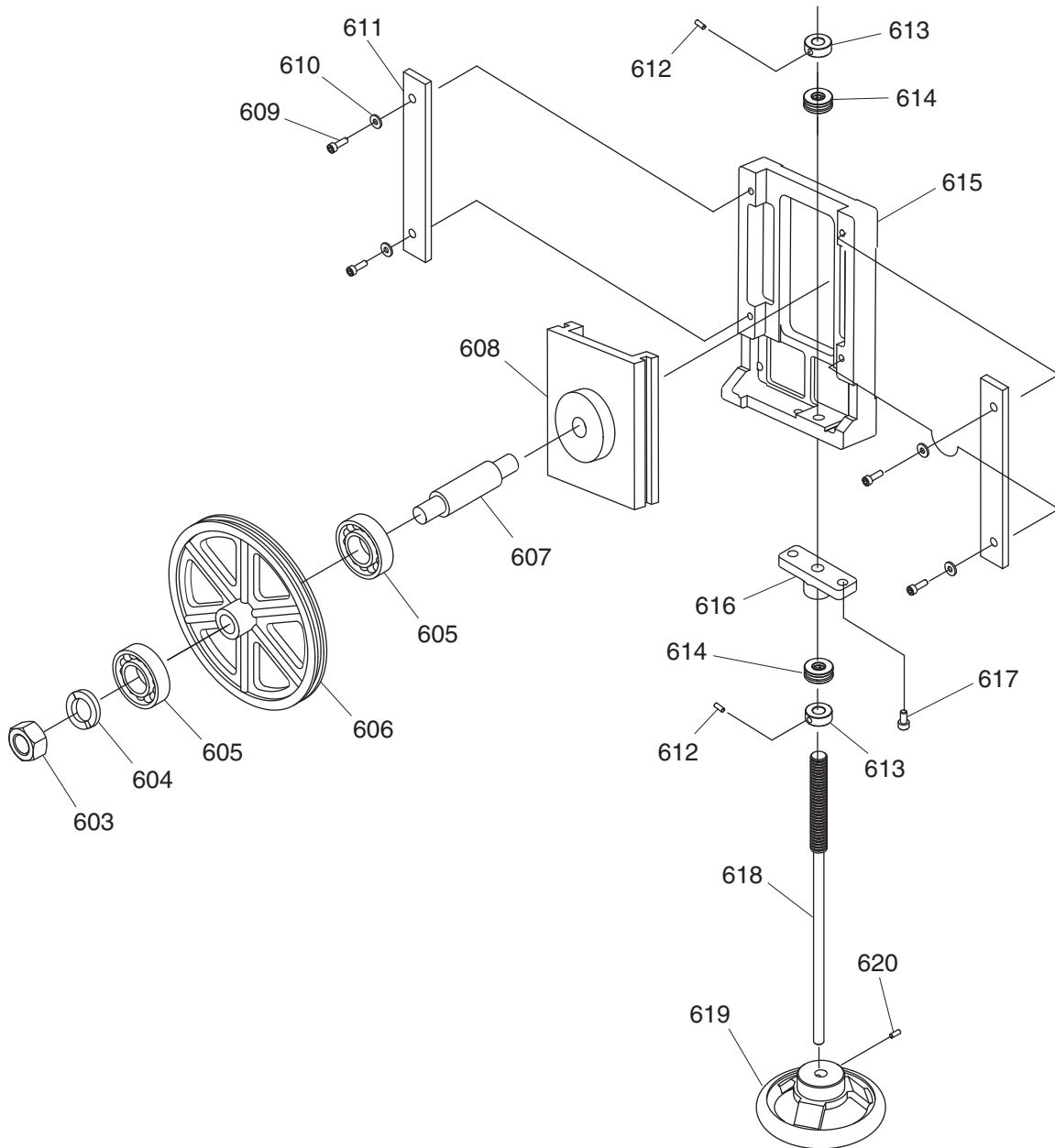


REF	PART #	DESCRIPTION
501	PSB15M	CAP SCREW M5-.8 X 20
502	PW02M	FLAT WASHER 5MM
503	P8144Z503	BLADE GUIDE
504	P8144Z504	BLADE GUIDE BRACKET UPPER
505	P8144Z505	BLADE SUPPORT
506	PSB02M	CAP SCREW M6-1 X 20
507	PRP102M	ROLL PIN 4 X 36
508	P8146Z508	GUIDE POST CLAMP PLATE
509	P8146Z509	GUIDE POST RACK
510	P8146Z510	GUIDE POST BRACKET
511	P8146Z511	SPECIAL FLAT WASHER 13 X 35 X T2
512	P8146Z512	LOCK KNOB 7/16-14 X 7/8
513	P8146Z513	SPECIAL SCREW 1/2-12 X 9/16

REF	PART #	DESCRIPTION
514	P8146Z514	GUIDE POST PINION GEAR 15T OD 32MM
515	P8146Z515	WORM GEAR P6.2832 OD 27MM
516	P8146Z516	COLLAR
517	P8146Z517	HANDWHEEL HANDLE
518	P8146Z518	HANDWHEEL
519	PSS02M	SET SCREW M6-1 X 6
520	P8146Z520	BRACKET
521	PLW03M	LOCK WASHER 6MM
522	PSB02M	CAP SCREW M6-1 X 20
523	P8146Z523	BLADE GUARD
524	PW04M	FLAT WASHER 10MM
525	PSB146M	CAP SCREW M10-1.5 X 15



# G8146Z Upper Wheel Breakdown & Parts List

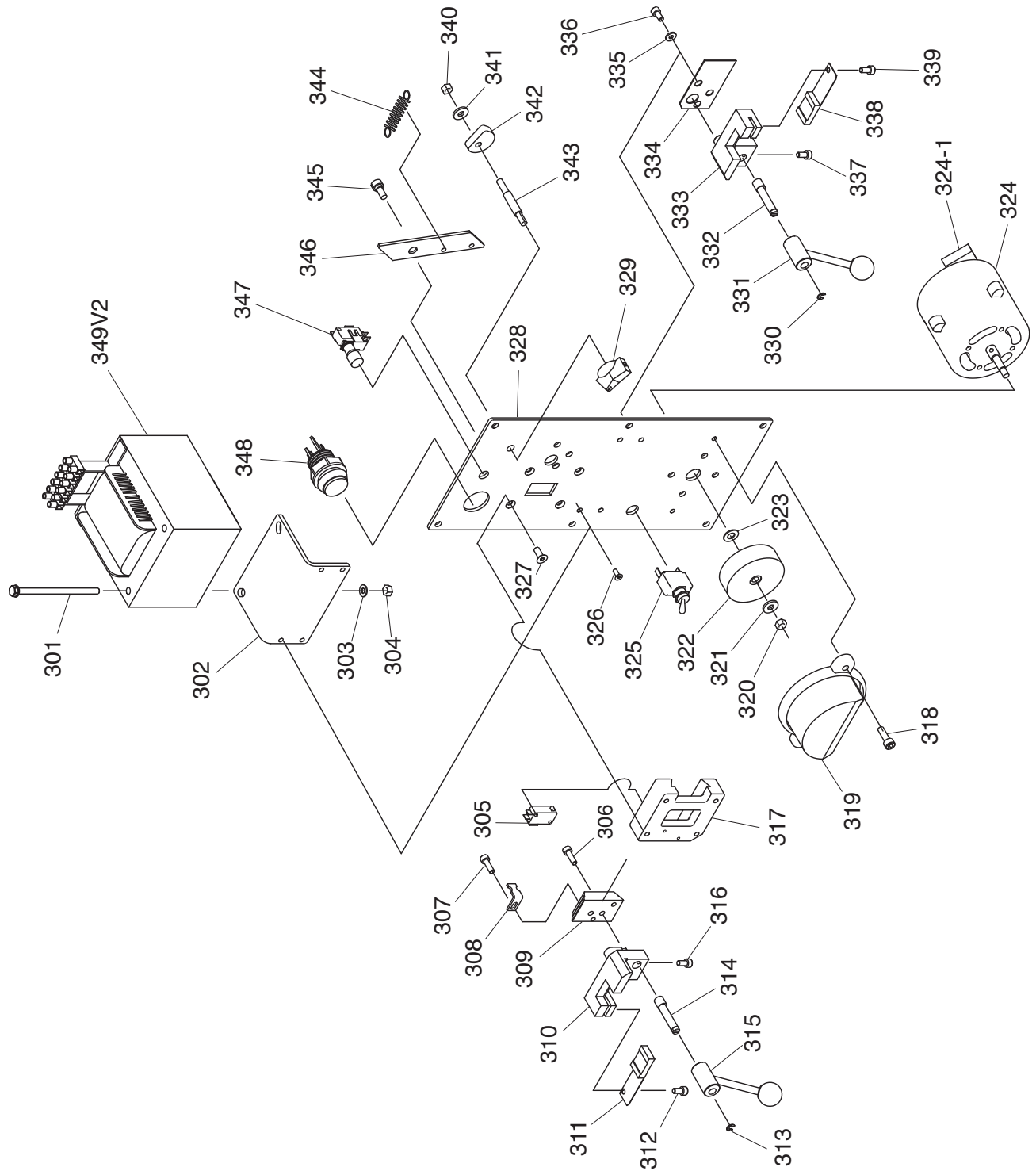


REF	PART #	DESCRIPTION
603	PN09	HEX NUT 5/8-18
604	PLW06	LOCK WASHER 5/8
605	P6304	BALL BEARING 6304ZZ
606	P8146Z606	WHEEL UPPER
607	P8146Z607	UPPER WHEEL SHAFT
608	P8146Z608	SLIDING BLOCK
609	PB07M	HEX BOLT M8-1.25 X 25
610	PLW04M	LOCK WASHER 8MM
611	P8146Z611	LOCK PLATE

REF	PART #	DESCRIPTION
612	PSS02M	SET SCREW M6-1 X 6
613	P8146Z613	COLLAR
614	P2901	THRUST BEARING 2901
615	P8146Z615	TENSIONING WAY
616	P8146Z616	LEADSCREW BRACKET
617	PSB31M	CAP SCREW M8-1.25 X 25
618	P8146Z618	LEADSCREW 5/8-18 X 11-13/16
619	P8146Z619	HANDWHEEL
620	PSS16M	SET SCREW M8-1.25 X 10



# Welder Station Breakdown



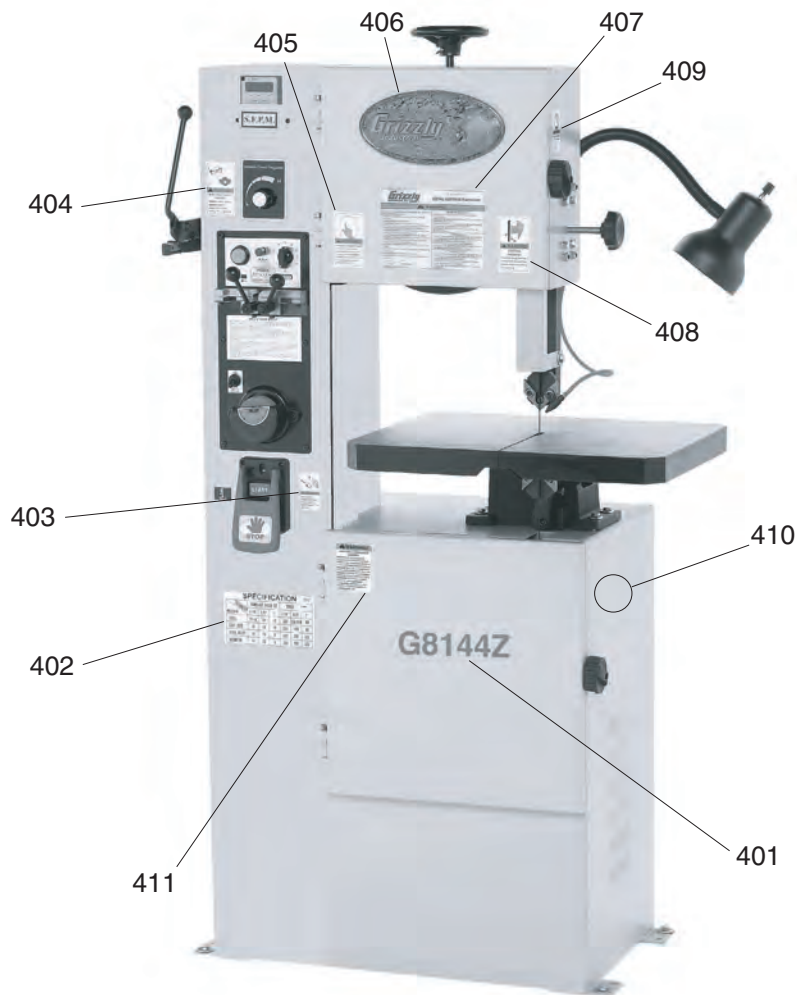
# Welder Station Parts List

REF	PART #	DESCRIPTION
301	PB96	HEX BOLT 1/4-20 X 4
302	P8144Z302	TRANSFORMER BRACKET
303	PW06	FLAT WASHER 1/4
304	PN05	HEX NUT 1/4-20
305	P8144Z305	LIMIT SWITCH
306	PSB06M	CAP SCREW M6-1 X 25
307	PSB04M	CAP SCREW M6-1 X 10
308	P8144Z308	LIMIT SWITCH BRACKET
309	P8144Z309	SLIDING BLOCK
310	P8144Z310	WELDING CLAMP LEFT
311	P8144Z311	WELDING JAW LEFT
312	PSB26M	CAP SCREW M6-1 X 12
313	PEC02M	E-CLIP 4MM
314	P8144Z314	SHAFT
315	P8144Z315	CLAMP LEVER
316	PSB26M	CAP SCREW M6-1 X 12
317	P8144Z317	SLIDING BLOCK BASE
318	PS11M	PHLP HD SCR M6-1 X 16
319	P8144Z319	GRINDER COVER
320	PN01M	HEX NUT M6-1
321	PW03M	FLAT WASHER 6MM
322	P8144Z322	GRINDING WHEEL 2-1/2"D
323	PW03M	FLAT WASHER 6MM
324	P8144Z324	GRINDER MOTOR 1/8HP 220V 1PH
324-1	P8144Z324-1	S CAPACITOR 3M 250V 3/4 X 1-1/4
325	P8144Z325	ON/OFF SWITCH

REF	PART #	DESCRIPTION
326	PS11M	PHLP HD SCR M6-1 X 16
327	PS26M	PHLP HD SCR M6-1 X 20
328	P8144Z328	WELDING PANEL
329	P8144Z329	CLAMP PRESSURE KNOB
330	PEC02M	E-CLIP 4MM
331	P8144Z331	CLAMP LEVER
332	P8144Z332	SHAFT
333	P8144Z333	WELDING CLAMP RIGHT
334	P8144Z334	INSULATING PLATE
335	PW03M	FLAT WASHER 6MM
336	PSB02M	CAP SCREW M6-1 X 20
337	PSB02M	CAP SCREW M6-1 X 20
338	P8144Z338	WELDING JAW RIGHT
339	PSB02M	CAP SCREW M6-1 X 20
340	PN01M	HEX NUT M6-1
341	PW03M	FLAT WASHER 6MM
342	P8144Z342	PRESSURE CAM
343	P8144Z343	CAM SHAFT
344	P8144Z344	TENSION SPRING 0.8 X 25MM
345	PS04	PHLP HD SCR 1/4-20 X 1/2
346	P8144Z346	BRACKET
347	P8144Z347	ANNEALING PUSH BUTTON
348	P8144Z348	WELDING PUSH BUTTON
349	P8144Z349	TRANSFORMER 1.2KVA 220V (G8144Z)
349	P8145Z349	TRANSFORMER 2KVA 220V (G8145Z)
349	P8146Z349	TRANSFORMER 4.2KVA 220V (G8146Z)



# Label Placement & List



REF	PART #	DESCRIPTION
401	P8144Z401	MODEL # LABEL (G8144Z)
401	P8145Z401	MODEL # LABEL (G8145Z)
401	P8146Z401	MODEL # LABEL (G8146Z)
402	P8144Z402	BLADE SPECIFICATION LABEL
403	P8144Z403	POWER DISCONNECT LABEL VERT S
404	P8144Z404	EYE/LUNG HAZARD LABEL VERT L
405	P8144Z405	READ MANUAL LABEL VERT L
406	G8588	GRIZZLY NAMEPLATE 9-1/2" X 4-1/2"

REF	PART #	DESCRIPTION
407	P8144Z407	MACHINE ID LABEL (G8144Z)
407	P8145Z407	MACHINE ID LABEL (G8145Z)
407	P8146Z407	MACHINE ID LABEL (G8146Z)
408	P8144Z408	BLADE HAZARD LABEL VERT L
409	P8144Z409	DOOR INJURY HAZARD LABEL VERT S
410	PPAINT-11	GRIZZLY PUTTY TOUCH UP PAINT
411	P8144Z411	UNSTABLE WORKPIECE LABEL

## WARNING

Safety labels warn about machine hazards and ways to prevent injury. The owner of this machine **MUST** maintain the original location and readability of the labels on the machine. If any label is removed or becomes unreadable, **REPLACE** that label before using the machine again. Contact Grizzly at (800) 523-4777 or [www.grizzly.com](http://www.grizzly.com) to order new labels.



# WARRANTY AND RETURNS

---

---

Grizzly Industrial, Inc. warrants every product it sells for a period of **1 year** to the original purchaser from the date of purchase. This warranty does not apply to defects due directly or indirectly to misuse, abuse, negligence, accidents, repairs or alterations or lack of maintenance. This is Grizzly's sole written warranty and any and all warranties that may be implied by law, including any merchantability or fitness, for any particular purpose, are hereby limited to the duration of this written warranty. We do not warrant or represent that the merchandise complies with the provisions of any law or acts unless the manufacturer so warrants. In no event shall Grizzly's liability under this warranty exceed the purchase price paid for the product and any legal actions brought against Grizzly shall be tried in the State of Washington, County of Whatcom.

We shall in no event be liable for death, injuries to persons or property or for incidental, contingent, special, or consequential damages arising from the use of our products.

To take advantage of this warranty, contact us by mail or phone and give us all the details. We will then issue you a "Return Number," which must be clearly posted on the outside as well as the inside of the carton. We will not accept any item back without this number. Proof of purchase must accompany the merchandise.

The manufacturers reserve the right to change specifications at any time because they constantly strive to achieve better quality equipment. We make every effort to ensure that our products meet high quality and durability standards and we hope you never need to use this warranty.

Please feel free to write or call us if you have any questions about the machine or the manual.

Thank you again for your business and continued support. We hope to serve you again soon.

**grizzly.com**<sup>®</sup>  
**TOOL WEBSITE**

Buy Direct and Save with Grizzly<sup>®</sup> – Trusted, Proven and a Great Value!  
~Since 1983~

*Visit Our Website Today For  
Current Specials!*

**ORDER  
24 HOURS A DAY!  
1-800-523-4777**

