

Grizzly **Industrial, Inc.**®

MODEL G7945 G7946 RADIAL DRILL PRESS

OWNER'S MANUAL

(For models manufactured since 10/23)

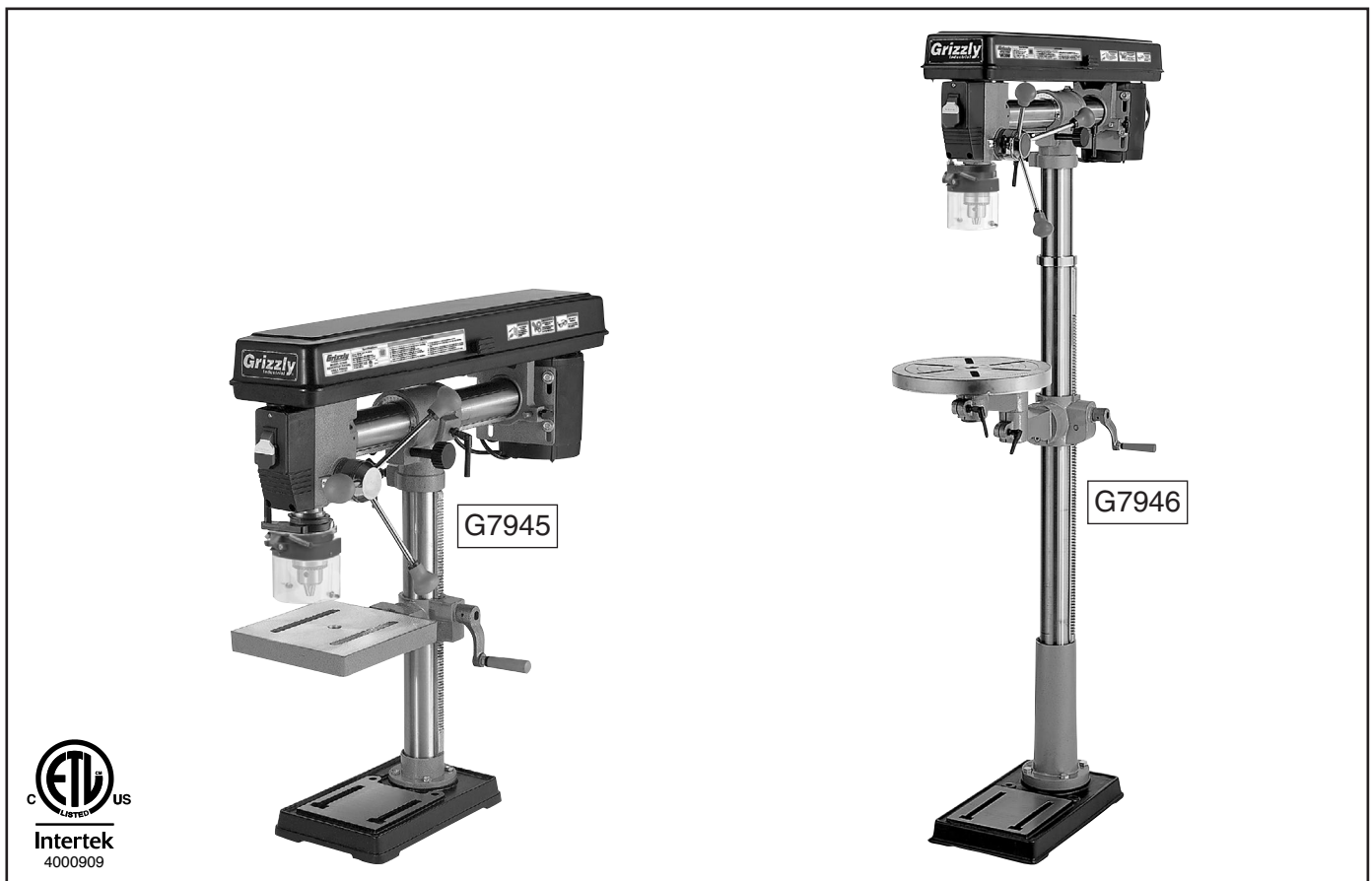

COPYRIGHT © JANUARY, 2001 BY GRIZZLY INDUSTRIAL, INC., REVISED SEPTEMBER, 2023 (BL)
**WARNING: NO PORTION OF THIS MANUAL MAY BE REPRODUCED IN ANY SHAPE
OR FORM WITHOUT THE WRITTEN APPROVAL OF GRIZZLY INDUSTRIAL, INC.**
#DS3698 PRINTED IN CHINA

V4.09.23

*****Keep for Future Reference*****



WARNING!

This manual provides critical safety instructions on the proper setup, operation, maintenance, and service of this machine/tool. Save this document, refer to it often, and use it to instruct other operators.

Failure to read, understand and follow the instructions in this manual may result in fire or serious personal injury—including amputation, electrocution, or death.

The owner of this machine/tool is solely responsible for its safe use. This responsibility includes but is not limited to proper installation in a safe environment, personnel training and usage authorization, proper inspection and maintenance, manual availability and comprehension, application of safety devices, cutting/sanding/grinding tool integrity, and the usage of personal protective equipment.

The manufacturer will not be held liable for injury or property damage from negligence, improper training, machine modifications or misuse.



WARNING!

Some dust created by power sanding, sawing, grinding, drilling, and other construction activities contains chemicals known to the State of California to cause cancer, birth defects or other reproductive harm. Some examples of these chemicals are:

- **Lead from lead-based paints.**
- **Crystalline silica from bricks, cement and other masonry products.**
- **Arsenic and chromium from chemically-treated lumber.**

Your risk from these exposures varies, depending on how often you do this type of work. To reduce your exposure to these chemicals: Work in a well ventilated area, and work with approved safety equipment, such as those dust masks that are specially designed to filter out microscopic particles.

Table of Contents

INTRODUCTION	2	SECTION 5: ACCESSORIES	33
Contact Info.....	2	SECTION 6: MAINTENANCE	34
Machine Description	2	General	34
Manual Accuracy	2	Cleaning & Protecting	34
Identification.....	3	Lubrication	34
Controls & Components.....	4	V-Belt	34
G7945 Machine Data Sheet	5	SECTION 7: SERVICE	35
G7946 Machine Data Sheet	7	Troubleshooting	35
SECTION 1: SAFETY	9	Calibrating Depth Stop.....	38
Safety Instructions for Machinery	9	Tensioning Spindle Return Spring.....	38
Additional Safety for Drill Presses	11	SECTION 8: WIRING	40
SECTION 2: POWER SUPPLY	12	Wiring Safety Instructions	40
SECTION 3: SETUP	14	G7945/G7946 Wiring Diagram	41
Needed for Setup.....	14	Electrical Components.....	41
Unpacking	14	SECTION 9: PARTS	42
Inventory	15	G7945/G7946 Main Parts	42
Cleanup.....	16	G7945 Column Parts	44
Site Considerations.....	17	G7946 Column Parts	45
Mounting to Workbench (G7945).....	18	G7945/G7946 Labels & Cosmetics	47
Anchoring to Floor (G7946)	18	WARRANTY & RETURNS	49
Mounting to Mobile Base (G7946).....	19		
Assembly	20		
Joining Drill Chuck & Arbor.....	23		
Test Run	24		
Spindle Break-In	25		
SECTION 4: OPERATIONS	26		
Operation Overview	26		
Choosing Speeds.....	27		
Changing Spindle Speed	28		
Drilling	28		
Installing/Removing Drill Bits	29		
Adjusting Depth Stop	30		
Adjusting Table	30		
Adjusting Headstock	32		

INTRODUCTION

Contact Info

We stand behind our machines! If you have questions or need help, contact us with the information below. Before contacting, make sure you get the **serial number** and **manufacture date** from the machine ID label. This will help us help you faster.

Grizzly Technical Support
1815 W. Battlefield
Springfield, MO 65807
Phone: (570) 546-9663
Email: techsupport@grizzly.com

We want your feedback on this manual. What did you like about it? Where could it be improved? Please take a few minutes to give us feedback.

Grizzly Documentation Manager
P.O. Box 2069
Bellingham, WA 98227-2069
Email: manuals@grizzly.com

Machine Description

The G7945 and G7946 function and operate the same but have the following differences:

G7945

- Table Size.....9"L x 8⁵/₈"W
- Max. Movement of Work Table.....9¹/₂"
- Number of T-Slots 2
- Swing..... 34"
- Floor-to-Table Height6¹/₂"–16"
- Max. Distance From Chuck to Table.... 12³/₄"
- Spindle Taper JT#33

G7946

- Table Size..... 12³/₁₆" Dia.
- Max. Movement of Work Table..... 24¹/₂"
- Number of T-Slots 6
- Swing..... 34"
- Floor-to-Table Height 22¹/₂"–47"
- Max. Distance From Chuck to Table.... 29¹/₂"
- Spindle Taper JT#33

Manual Accuracy

We are proud to provide a high-quality owner's manual with your new machine!

We made every effort to be exact with the instructions, specifications, drawings, and photographs in this manual. Sometimes we make mistakes, but our policy of continuous improvement also means that **sometimes the machine you receive is slightly different than shown in the manual.**

If you find this to be the case, and the difference between the manual and machine leaves you confused or unsure about something, check our website for an updated version. We post current manuals and manual updates for free on our website at www.grizzly.com.

Alternatively, you can call our Technical Support for help. Before calling, make sure you write down the **manufacture date** and **serial number** from the machine ID label (see below). This information is required for us to provide proper tech support, and it helps us determine if updated documentation is available for your machine.

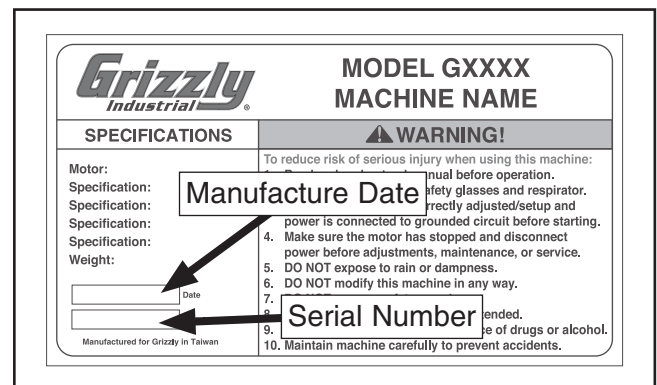

Identification

Become familiar with the names and locations of the controls and features shown below to better understand the instructions in this manual.

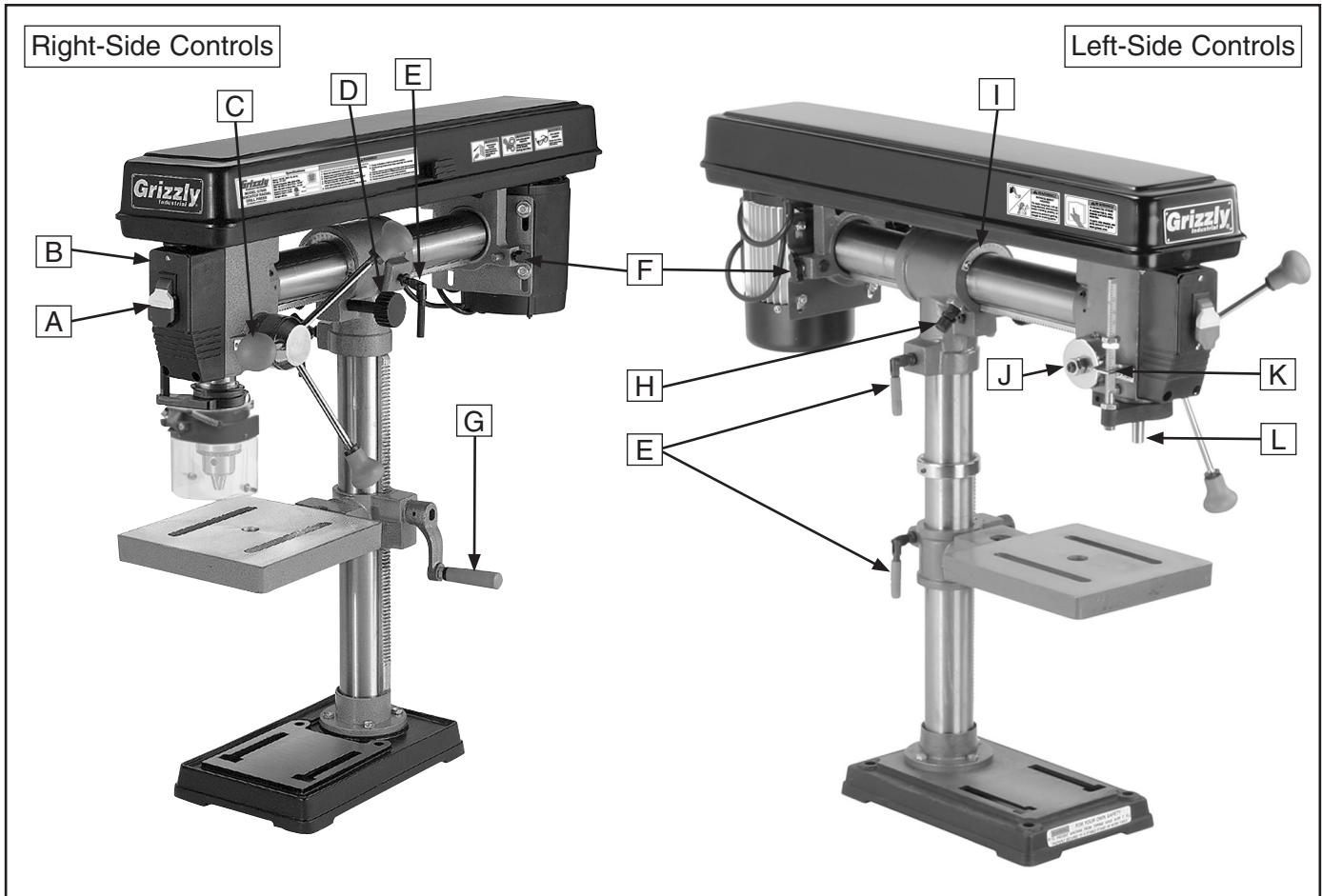

- A. Power Switch
- B. Headstock
- C. Downfeed Handles
- D. Horizontal Adjustment Knob
- E. Lock Levers
- F. Belt Tension Lock Knobs

- G. Crank Handle
- H. Lock Pin
- I. Headstock Angle Tilt Scale
- J. Spindle Return Spring
- K. Depth Stop
- L. Spindle

WARNING

For Your Own Safety Read Instruction Manual Before Operating Drill Press

- a) Wear eye protection.
- b) Do not wear gloves, necktie, or loose clothing.
- c) Clamp workpiece or brace against column to prevent rotation.
- d) Use recommended speed for drill accessory and workpiece material.



Controls & Components



Refer to the following figures and descriptions to become familiar with the basic controls and components of this machine. Understanding these items and how they work will help you understand the rest of the manual and minimize your risk of injury when operating this machine.

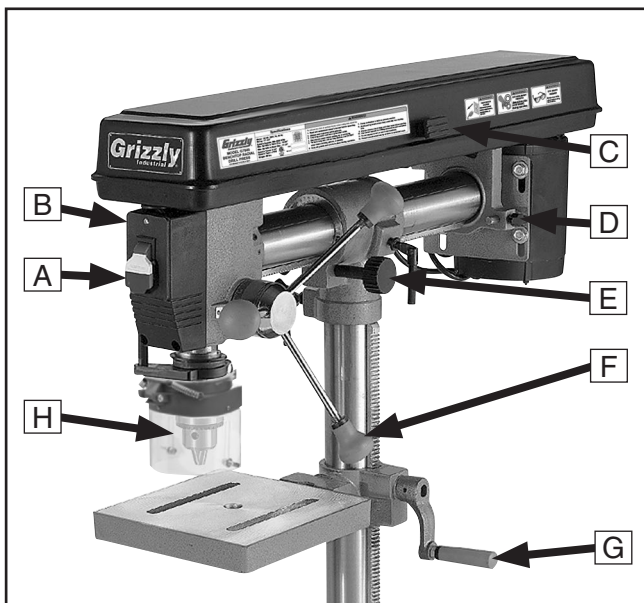

Figure 1. Machine controls (right).

- A. **Power Switch:** Turns motor *ON/OFF*.
- B. **Headstock:** The cast-iron upper portion of the drill press, which houses the quill and supports the motor and belt housing.
- C. **Belt Cover:** Provides access to drive belt for spindle-speed changes.
- D. **Belt Tension Lock Knobs:** Secures motor in position to set belt tension.

- E. **Horizontal Adjustment Knob:** Moves the headstock forward and backward over the column.
- F. **Downfeed Handles:** Move the quill up and down.
- G. **Table Height Crank Handle:** Raises/lowers table.
- H. **Chuck Guard & Chuck:** Chuck guard protects user from flying debris; chuck accepts drill bits from 1/16" to 5/8" and mounts to the spindle with a JT#33 taper.

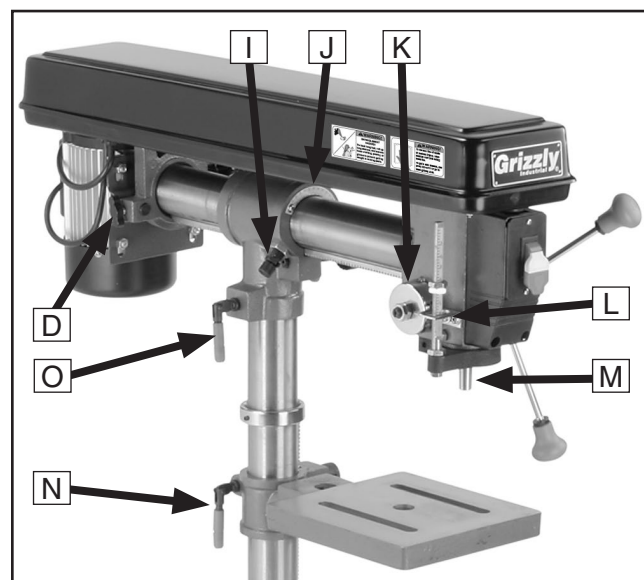

Figure 2. Machine controls (left).

- I. **Headstock 90° Lock Pin:** Engages when headstock is positioned with spindle at 90° to table. When pulled out, allows headstock to be tilted left/right.
- J. **Scale:** Indicates headstock angle.
- K. **Spindle Return Spring:** Automatically returns quill into headstock.
- L. **Depth Stop:** Limits quill travel to a pre-set drilling depth.
- M. **Spindle:** Used to mount chuck and milling accessories with a JT#33 taper.
- N. **Table Rotation Lock Lever:** Locks table rotation.
- O. **Column Lock Lever:** Locks table height.





MACHINE DATA SHEET

Customer Service #: (570) 546-9663 · To Order Call: (800) 523-4777 · Fax #: (800) 438-5901

MODEL G7945 BENCHTOP RADIAL DRILL PRESS

Product Dimensions:

Weight..... 88 lbs.
 Width (side-to-side) x Depth (front-to-back) x Height..... 11-1/2 x 33-1/2 x 31-1/2 in.
 Footprint (Length x Width)..... 13-1/2 x 8-1/2 in.

Shipping Dimensions:

Type..... Cardboard Box
 Content..... Machine
 Weight..... 97 lbs.
 Length x Width x Height..... 36 x 18 x 13 in.
 Must Ship Upright..... No

Electrical:

Power Requirement..... 120V, Single-Phase, 60 Hz
 Full-Load Current Rating..... 7A
 Minimum Circuit Size..... 15A
 Connection Type..... Cord & Plug
 Power Cord Included..... Yes
 Power Cord Length..... 7 ft.
 Power Cord Gauge..... 18 AWG
 Plug Included..... Yes
 Included Plug Type..... 5-15
 Switch Type..... Paddle Safety Switch w/Removable Key

Motors:

Main

Horsepower..... 1/2 HP
 Phase..... Single-Phase
 Amps..... 7A
 Speed..... 1725 RPM
 Type..... TEFC Capacitor-Start Induction
 Power Transfer..... V-Belt Drive
 Bearings..... Shielded & Permanently Lubricated
 Centrifugal Switch/Contacts Type..... Internal



Main Specifications:

Operation Information

Type.....	Radial
Swing.....	34 in.
Spindle Taper.....	JT#33
Spindle Travel.....	3-1/4 in.
Max. Distance From Spindle to Column.....	5-1/2 – 17 in.
Max. Distance From Spindle to Table.....	12-3/4 in.
Number of Spindle Speeds.....	5
Range of Spindle Speeds.....	550 – 3000 RPM
Max. Head Tilt (Left/Right).....	Left 90/Right 45 deg.
Max. Head Swivel.....	360 deg.
Drilling Capacity (Mild Steel).....	1/2 in.
Drill Chuck Type.....	JT33 Key Chuck
Drill Chuck Size.....	1/16 – 5/8 in.

Spindle Information

Distance From Spindle to Base.....	17-1/2 in.
Quill Diameter.....	1.575 in.

Table Information

Max. Table Tilt (Left/Right).....	90 deg.
Table Swing.....	360 deg.
Table Swivel Around Center.....	360 deg.
Table Swivel Around Column.....	360 deg.
Max. Movement of Work Table.....	9-1/2 in.
Table Length.....	9 in.
Table Width.....	8-5/8 in.
Table Thickness.....	1-1/4 in.
Vertical Table Travel.....	Crank Handle Operation
Number of T-Slots.....	2
T-Slot Size.....	5/8 in.
T-Slot Centers.....	6 in.
Floor-To-Table Height.....	6-1/2 – 16 in.

Construction

Table.....	Precision-Ground Cast Iron
Column.....	Steel
Spindle Housing.....	Cast Iron
Head.....	Cast Iron
Base.....	Cast Iron
Paint Type/Finish.....	Enamel

Other Related Information

Base Length.....	13-1/2 in.
Base Width.....	8-1/2 in.
Column Diameter.....	2.360 in.
Depth Stop Type.....	Threaded Rod with Positive Stop
Has Work Light.....	No

Other Specifications:

Country of Origin	China
Warranty	1 Year
Approximate Assembly & Setup Time	30 Minutes
Serial Number Location	ID Label on Head
ISO 9001 Factory	Yes
Certified by a Nationally Recognized Testing Laboratory (NRTL)	Yes
Awards	Popular Woodworking Editor's Choice Tool Buying Guide





MACHINE DATA SHEET

Customer Service #: (570) 546-9663 · To Order Call: (800) 523-4777 · Fax #: (800) 438-5901

MODEL G7946 FLOOR RADIAL DRILL PRESS

Product Dimensions:

Weight..... 128 lbs.
Width (side-to-side) x Depth (front-to-back) x Height..... 14 x 32 x 64-1/2 in.
Footprint (Length x Width)..... 18 x 11 in.

Shipping Dimensions:

Type..... Cardboard Box on Wood Pallet
Content..... Machine
Weight..... 170 lbs.
Length x Width x Height..... 56 x 20 x 14 in.
Must Ship Upright..... No

Electrical:

Power Requirement..... 120V, Single-Phase, 60 Hz
Full-Load Current Rating..... 7A
Minimum Circuit Size..... 15A
Connection Type..... Cord & Plug
Power Cord Included..... Yes
Power Cord Length..... 7 ft.
Power Cord Gauge..... 18 AWG
Plug Included..... Yes
Included Plug Type..... 5-15
Switch Type..... Paddle Safety Switch w/Removable Key

Motors:

Main

Horsepower..... 1/2 HP
Phase..... Single-Phase
Amps..... 7A
Speed..... 1725 RPM
Type..... TEFC Capacitor-Start Induction
Power Transfer V-Belt Drive
Bearings..... Shielded & Permanently Lubricated
Centrifugal Switch/Contacts Type..... Internal



Main Specifications:

Operation Information

Type.....	Radial
Swing.....	34 in.
Spindle Taper.....	JT#33
Spindle Travel.....	3-1/4 in.
Max. Distance From Spindle to Column.....	5-1/2 – 17 in.
Max. Distance From Spindle to Table.....	29-1/2 in.
Number of Spindle Speeds.....	5
Range of Spindle Speeds.....	550 – 3000 RPM
Max. Head Tilt (Left/Right).....	Left 90/Right 45 deg.
Max. Head Swivel.....	360 deg.
Drilling Capacity (Mild Steel).....	1/2 in. in Steel
Drill Chuck Type.....	JT33 Key Chuck
Drill Chuck Size.....	1/16 – 5/8 in.

Spindle Information

Distance From Spindle to Base.....	49-3/4 in.
Quill Diameter.....	1.575 in.

Table Information

Max. Table Tilt (Left/Right).....	90 deg.
Table Swing.....	360 deg.
Table Swivel Around Center.....	360 deg.
Table Swivel Around Column.....	360 deg.
Max. Movement of Work Table.....	24-1/2 in.
Table Diameter.....	12-3/16 in.
Table Thickness.....	1 in.
Vertical Table Travel.....	Crank Handle Operation
Number of T-Slots.....	6
T-Slot Size.....	5/8 in.
T-Slot Centers.....	3-1/4 in.
Floor-To-Table Height.....	22-1/2 – 47 in.

Construction

Table.....	Precision-Ground Cast Iron
Column.....	Steel
Spindle Housing.....	Cast Iron
Head.....	Cast Iron
Base.....	Cast Iron
Paint Type/Finish.....	Enamel

Other Related Information

Base Length.....	17-1/2 in.
Base Width.....	10-1/2 in.
Mobile Base.....	D2260A
Column Diameter.....	2.790 in.
Depth Stop Type.....	Hub
Has Work Light.....	No

Other Specifications:

Country of Origin	China
Warranty	1 Year
Approximate Assembly & Setup Time	30 Minutes
Serial Number Location	ID Label on Head
ISO 9001 Factory	Yes
Certified by a Nationally Recognized Testing Laboratory (NRTL)	Yes
Awards	Popular Woodworking Editor's Choice Tool Buying Guide



SECTION 1: SAFETY

For Your Own Safety, Read Instruction Manual Before Operating This Machine

The purpose of safety symbols is to attract your attention to possible hazardous conditions. This manual uses a series of symbols and signal words intended to convey the level of importance of the safety messages. The progression of symbols is described below. Remember that safety messages by themselves do not eliminate danger and are not a substitute for proper accident prevention measures. Always use common sense and good judgment.

⚠ DANGER Indicates an imminently hazardous situation which, if not avoided, **WILL** result in death or serious injury.

⚠ WARNING Indicates a potentially hazardous situation which, if not avoided, **COULD** result in death or serious injury.

⚠ CAUTION Indicates a potentially hazardous situation which, if not avoided, **MAY** result in minor or moderate injury. It may also be used to alert against unsafe practices.

NOTICE Alerts the user to useful information about proper operation of the machine to avoid machine damage.

Safety Instructions for Machinery

⚠ WARNING

OWNER'S MANUAL. Read and understand this owner's manual **BEFORE** using machine.

TRAINED OPERATORS ONLY. Untrained operators have a higher risk of being hurt or killed. Only allow trained/supervised people to use this machine. When machine is not being used, disconnect power, remove switch keys, or lock-out machine to prevent unauthorized use—especially around children. Make your workshop kid proof!

DANGEROUS ENVIRONMENTS. Do not use machinery in areas that are wet, cluttered, or have poor lighting. Operating machinery in these areas greatly increases the risk of accidents and injury.

MENTAL ALERTNESS REQUIRED. Full mental alertness is required for safe operation of machinery. Never operate under the influence of drugs or alcohol, when tired, or when distracted.

ELECTRICAL EQUIPMENT INJURY RISKS. You can be shocked, burned, or killed by touching live electrical components or improperly grounded machinery. To reduce this risk, only allow qualified service personnel to do electrical installation or repair work, and always disconnect power before accessing or exposing electrical equipment.

DISCONNECT POWER FIRST. Always disconnect machine from power supply **BEFORE** making adjustments, changing tooling, or servicing machine. This prevents an injury risk from unintended startup or contact with live electrical components.

EYE PROTECTION. Always wear ANSI-approved safety glasses or a face shield when operating or observing machinery to reduce the risk of eye injury or blindness from flying particles. Everyday eyeglasses are **NOT** approved safety glasses.



WARNING

WEARING PROPER APPAREL. Do not wear loose clothing, gloves, neckties, or jewelry that can become entangled in moving parts. Always tie back or cover long hair. Wear non-slip footwear to reduce risk of slipping and losing control or accidentally contacting cutting tool or moving parts.

HAZARDOUS DUST. Dust created by machinery operations may cause cancer, birth defects, or long-term respiratory damage. Be aware of dust hazards associated with each workpiece material. Always wear a NIOSH-approved respirator to reduce your risk.

HEARING PROTECTION. Always wear hearing protection when operating or observing loud machinery. Extended exposure to this noise without hearing protection can cause permanent hearing loss.

REMOVE ADJUSTING TOOLS. Tools left on machinery can become dangerous projectiles upon startup. Never leave chuck keys, wrenches, or any other tools on machine. Always verify removal before starting!

USE CORRECT TOOL FOR THE JOB. Only use this tool for its intended purpose—do not force it or an attachment to do a job for which it was not designed. Never make unapproved modifications—modifying tool or using it differently than intended may result in malfunction or mechanical failure that can lead to personal injury or death!

AWKWARD POSITIONS. Keep proper footing and balance at all times when operating machine. Do not overreach! Avoid awkward hand positions that make workpiece control difficult or increase the risk of accidental injury.

CHILDREN & BYSTANDERS. Keep children and bystanders at a safe distance from the work area. Stop using machine if they become a distraction.

GUARDS & COVERS. Guards and covers reduce accidental contact with moving parts or flying debris. Make sure they are properly installed, undamaged, and working correctly BEFORE operating machine.

FORCING MACHINERY. Do not force machine. It will do the job safer and better at the rate for which it was designed.

NEVER STAND ON MACHINE. Serious injury may occur if machine is tipped or if the cutting tool is unintentionally contacted.

STABLE MACHINE. Unexpected movement during operation greatly increases risk of injury or loss of control. Before starting, verify machine is stable and mobile base (if used) is locked.

USE RECOMMENDED ACCESSORIES. Consult this owner's manual or the manufacturer for recommended accessories. Using improper accessories will increase the risk of serious injury.

UNATTENDED OPERATION. To reduce the risk of accidental injury, turn machine **OFF** and ensure all moving parts completely stop before walking away. Never leave machine running while unattended.

MAINTAIN WITH CARE. Follow all maintenance instructions and lubrication schedules to keep machine in good working condition. A machine that is improperly maintained could malfunction, leading to serious personal injury or death.

DAMAGED PARTS. Regularly inspect machine for damaged, loose, or mis-adjusted parts—or any condition that could affect safe operation. Immediately repair/replace BEFORE operating machine. For your own safety, DO NOT operate machine with damaged parts!

MAINTAIN POWER CORDS. When disconnecting cord-connected machines from power, grab and pull the plug—NOT the cord. Pulling the cord may damage the wires inside. Do not handle cord/plug with wet hands. Avoid cord damage by keeping it away from heated surfaces, high traffic areas, harsh chemicals, and wet/damp locations.

EXPERIENCING DIFFICULTIES. If at any time you experience difficulties performing the intended operation, stop using the machine! Contact our Technical Support at (570) 546-9663.



Additional Safety for Drill Presses

WARNING

Serious injury or death can occur from getting clothing, jewelry, or long hair entangled in rotating spindle or bit/cutting tool. Contact with rotating bit/cutting tool can result in severe cuts or amputation of fingers. Flying metal chips can cause blindness or eye injuries. Broken bits/cutting tools, unsecured workpieces, chuck keys, or other adjustment tools thrown from rotating spindle can strike nearby operator or bystanders with deadly force. To reduce the risk of these hazards, operator and bystanders **MUST** completely heed hazards and warnings below.

EYE/FACE/HAND PROTECTION. Flying chips created by drilling can cause eye injuries or blindness. Always wear a face shield in addition to safety glasses. Always keep hands and fingers away from drill bit/cutting tool. Avoid awkward hand positions, where a sudden slip could cause hand to move into bit/cutting tool.

AVOIDING ENTANGLEMENT. DO NOT wear loose clothing, gloves, or jewelry. Tie back long hair. Keep all guards in place and secure. Always allow spindle to stop on its own. DO NOT stop spindle using your hand or any other object.

REMOVING ADJUSTMENT TOOLS. Chuck key, wrenches, and other tools left on machine can become deadly projectiles when spindle is started. Remove all loose items or tools used on spindle immediately after use.

CORRECT SPINDLE SPEED. Using wrong spindle speed can cause bits/cutting tools to break and strike operator or bystanders. Follow recommended speeds and feeds for each size/type of bit/cutting tool and workpiece material.

SECURING BIT/CUTTING TOOL. Firmly secure bit/cutting tool in chuck so it cannot fly out of spindle during operation or startup.

DRILLING PREPARATION. To avoid loss of drilling control or bit breakage, only drill into a flat surface that is approximately perpendicular to bit. Clear table of all objects before starting spindle. Never start spindle with bit pressed against workpiece.

SECURING TABLE AND HEADSTOCK. To avoid loss of control leading to accidental contact with tool/bit, tighten all table and headstock locks before operating drill press.

WORKPIECE CONTROL. An unsecured workpiece may unexpectedly shift, spin out of control, or be thrown if bit/cutting tool “grabs” during operation. Clamp workpiece to table or in table-mounted vise, or brace against column to prevent rotation. NEVER hold workpiece by hand during operation. NEVER start machine with bit/cutting tool touching workpiece; allow spindle to gain full speed before drilling.

INSPECTING BIT/CUTTING TOOL. Damaged bits/cutting tools may break apart during operation and hit operator or bystanders. Dull bits/cutting tools increase cutting resistance and are more likely to grab and spin/throw workpiece. Always inspect bits/cutting tools for sharpness, chips, or cracks before each use. Replace dull, chipped, or cracked bits/cutting tools immediately.

WARNING

Like all machinery there is potential danger when operating this machine. Accidents are frequently caused by lack of familiarity or failure to pay attention. Use this machine with respect and caution to decrease the risk of operator injury. If normal safety precautions are overlooked or ignored, serious personal injury may occur.

CAUTION

No list of safety guidelines can be complete. Every shop environment is different. Always consider safety first, as it applies to your individual working conditions. Use this and other machinery with caution and respect. Failure to do so could result in serious personal injury, damage to equipment, or poor work results.



SECTION 2: POWER SUPPLY

Availability

Before installing the machine, consider the availability and proximity of the required power supply circuit. If an existing circuit does not meet the requirements for this machine, a new circuit must be installed. To minimize the risk of electrocution, fire, or equipment damage, installation work and electrical wiring must be done by an electrician or qualified service personnel in accordance with all applicable codes and standards.

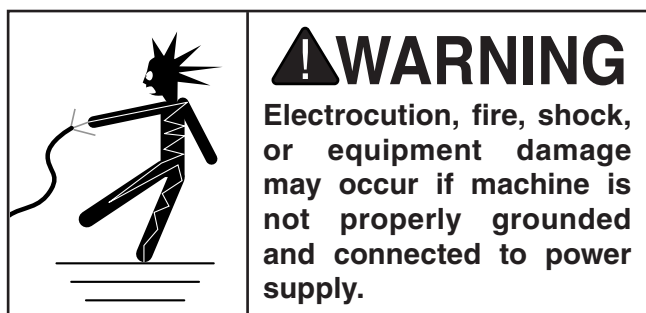

Full-Load Current Rating

The full-load current rating is the amperage a machine draws at 100% of the rated output power. On machines with multiple motors, this is the amperage drawn by the largest motor or sum of all motors and electrical devices that might operate at one time during normal operations.

Full-Load Current Rating at 120V

G7945.....	7 Amps
G7946.....	7 Amps

The full-load current is not the maximum amount of amps that the machine will draw. If the machine is overloaded, it will draw additional amps beyond the full-load rating.

If the machine is overloaded for a sufficient length of time, damage, overheating, or fire may result—especially if connected to an undersized circuit. To reduce the risk of these hazards, avoid overloading the machine during operation and make sure it is connected to a power supply circuit that meets the specified circuit requirements.

! WARNING

Serious injury could occur if you connect machine to power before completing setup process. DO NOT connect to power until instructed later in this manual.

120V Circuit Requirements

This machine is prewired to operate on a power supply circuit that has a verified ground and meets the following requirements:

Nominal Voltage	110V, 115V, 120V
Cycle	60 Hz
Phase	Single-Phase
Power Supply Circuit	15 Amps
Plug/Receptacle	NEMA 5-15

A power supply circuit includes all electrical equipment between the breaker box or fuse panel in the building and the machine. The power supply circuit used for this machine must be sized to safely handle the full-load current drawn from the machine for an extended period of time. (If this machine is connected to a circuit protected by fuses, use a time delay fuse marked D.)

! CAUTION

For your own safety and protection of property, consult an electrician if you are unsure about wiring practices or electrical codes in your area.

Note: *Circuit requirements in this manual apply to a dedicated circuit—where only one machine will be running on the circuit at a time. If machine will be connected to a shared circuit where multiple machines may be running at the same time, consult an electrician or qualified service personnel to ensure circuit is properly sized for safe operation.*



Grounding & Plug Requirements

This machine **MUST** be grounded. In the event of certain malfunctions or breakdowns, grounding reduces the risk of electric shock by providing a path of least resistance for electric current.

This machine is equipped with a power cord that has an equipment-grounding wire and a grounding plug. Only insert plug into a matching receptacle (outlet) that is properly installed and grounded in accordance with all local codes and ordinances. **DO NOT** modify the provided plug!

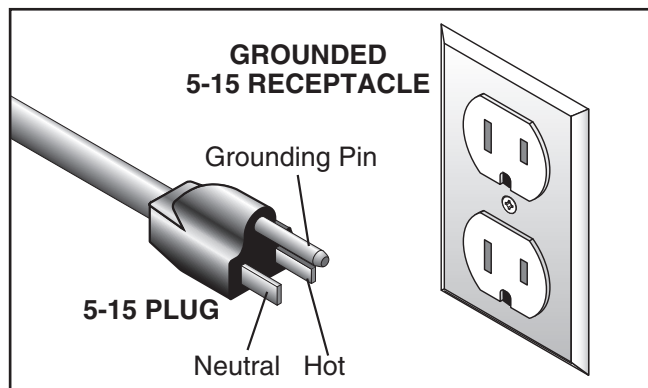

Figure 3. Typical 5-15 plug and receptacle.

⚠ CAUTION

SHOCK HAZARD!

Two-prong outlets do not meet the grounding requirements for this machine. Do not modify or use an adapter on the plug provided—if it will not fit the outlet, have a qualified electrician install the proper outlet with a verified ground.

Improper connection of the equipment-grounding wire can result in a risk of electric shock. The wire with green insulation (with or without yellow stripes) is the equipment-grounding wire. If repair or replacement of the power cord or plug is necessary, do not connect the equipment-grounding wire to a live (current carrying) terminal.

Check with a qualified electrician or service personnel if you do not understand these grounding requirements, or if you are in doubt about whether the tool is properly grounded. If you ever notice that a cord or plug is damaged or worn, disconnect it from power, and immediately replace it with a new one.

Extension Cords

We do not recommend using an extension cord with this machine. If you must use an extension cord, only use it if absolutely necessary and only on a temporary basis.

Extension cords cause voltage drop, which can damage electrical components and shorten motor life. Voltage drop increases as the extension cord size gets longer and the gauge size gets smaller (higher gauge numbers indicate smaller sizes).

Any extension cord used with this machine must be in good condition and contain a ground wire and matching plug/receptacle. Additionally, it must meet the following size requirements:

Minimum Gauge Size 14 AWG
Maximum Length (Shorter is Better).....50 ft.



SECTION 3: SETUP

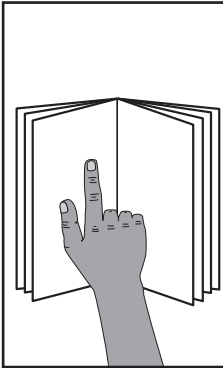

!WARNING

This machine presents serious injury hazards to untrained users. Read through this entire manual to become familiar with the controls and operations before starting the machine!

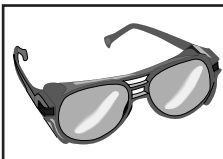

!WARNING

Wear safety glasses during the entire setup process!



!WARNING

HEAVY LIFT!

Straining or crushing injury may occur from improperly lifting machine or some of its parts. To reduce this risk, get help from other people and use a forklift (or other lifting equipment) rated for weight of this machine.

Needed for Setup

The following items are needed, but not included, for the setup/assembly of this machine.

Items Needed	Qty
Open-Ended Wrench 16mm.....	1
Open-Ended Wrench 3/4"	1
An Assistant for Lifting Help.....	1
Rubber Mallet.....	1
Mounting Hardware 1/2" (Page 18).....	Varies
Mineral Spirits.....	As Needed
Shop Rags.....	As Needed
Safety Glasses (Per Person)	1

Unpacking

This machine was carefully packaged for safe transport. When unpacking, separate all enclosed items from packaging materials and inspect them for shipping damage. ***If items are damaged, please call us immediately at (570) 546-9663.***

IMPORTANT: Save all packaging materials until you are completely satisfied with the machine and have resolved any issues between Grizzly or the shipping agent. ***You MUST have the original packaging to file a freight claim. It is also extremely helpful if you need to return your machine later.***



Inventory

If any nonproprietary parts are missing (e.g. a nut or a washer), we would be glad to replace them, but for the sake of expediency, you can get replacements at a hardware store.

Use **Figure 4** and the list below to inventory loose parts shipped with the machine:

Description	Qty	
A. Headstock	1	L. Table.....
B. Base	1	M. Lock Shoe (Headstock).....
C. Chuck Guard Assembly	1	N. Table Support Arm (G7946)
D. Wrench	1	O. Column Support Arm (G7946).....
E. Hex Bolt and Wingnut Set.....	1	P. Hardware Bag (Not Shown).....
F. Column	1	—Hex Bolts M8-1.25 x 20 (G7945)
G. Key	1	—Hex Bolts M10-1.5 x 40 (G7946).....
H. Chuck	1	—Hex Wrench 3mm.....
I. Lock Levers	2	—Hex Wrench 4mm.....
J. Crank Arm and Handle	1 Ea	—Phillips Head Screws M4-7 x 10.....
K. Downfeed Handles	3	—Flat Washers 4mm.....

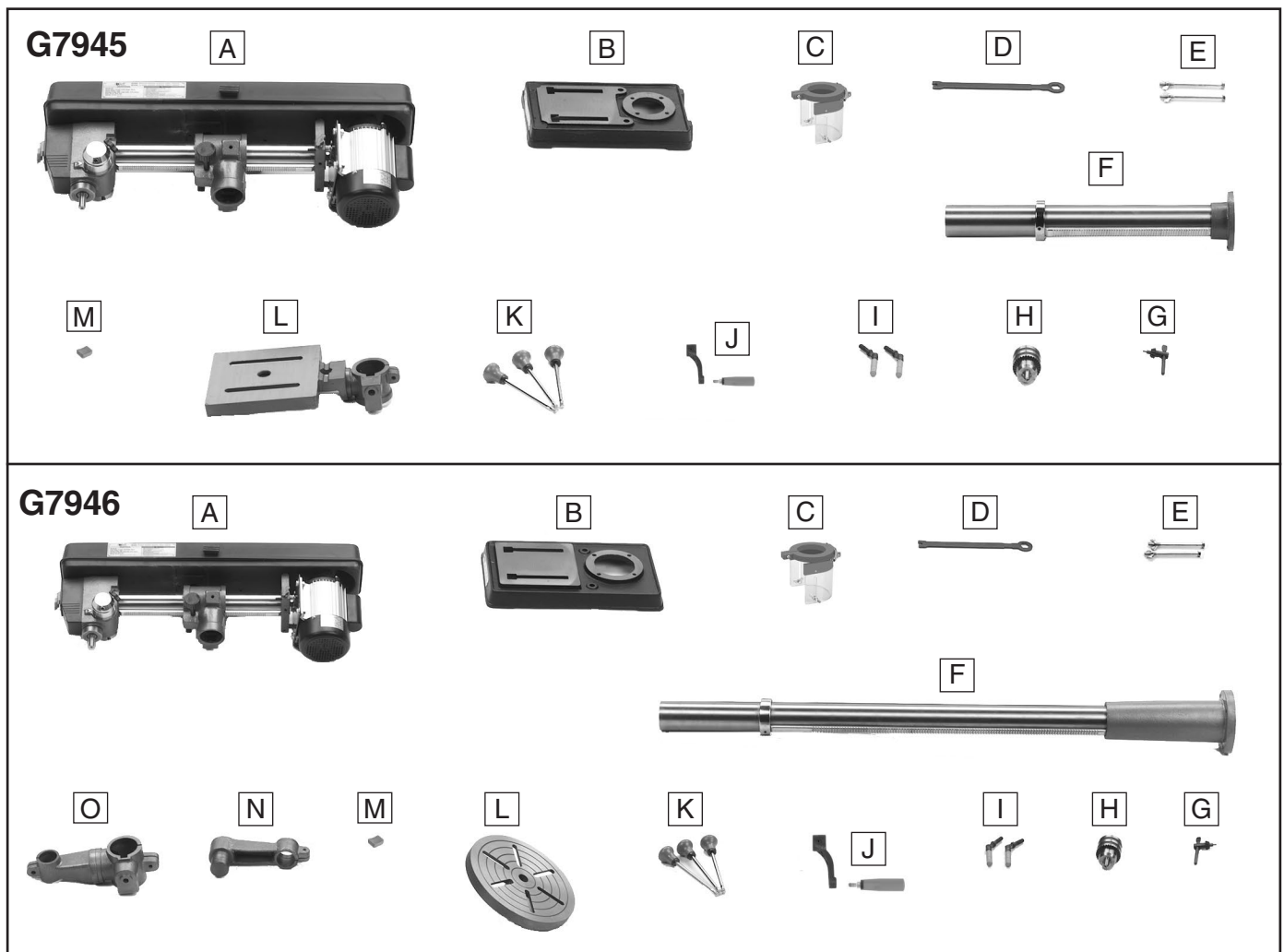

Figure 4. Parts inventory for Models G7945 (top) and G7946 (bottom).



Cleanup

The unpainted surfaces of your machine are coated with a heavy-duty rust preventative that prevents corrosion during shipment and storage. This rust preventative works extremely well, but it will take a little time to clean.

Be patient and do a thorough job cleaning your machine. The time you spend doing this now will give you a better appreciation for the proper care of your machine's unpainted surfaces.

There are many ways to remove this rust preventative, but the following steps work well in a wide variety of situations. Always follow the manufacturer's instructions with any cleaning product you use and make sure you work in a well-ventilated area to minimize exposure to toxic fumes.

Before cleaning, gather the following:

- Disposable rags
- Cleaner/degreaser (WD•40 works well)
- Safety glasses & disposable gloves
- Plastic paint scraper (optional)

Basic steps for removing rust preventative:

1. Put on safety glasses.
2. Coat the rust preventative with a liberal amount of cleaner/degreaser, then let it soak for 5–10 minutes.
3. Wipe off the surfaces. If your cleaner/degreaser is effective, the rust preventative will wipe off easily. If you have a plastic paint scraper, scrape off as much as you can first, then wipe off the rest with the rag.
4. Repeat **Steps 2–3** as necessary until clean, then coat all unpainted surfaces with a quality metal protectant to prevent rust.

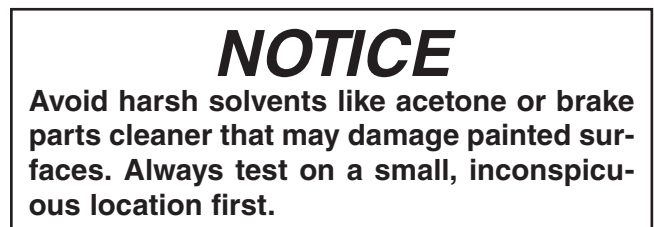
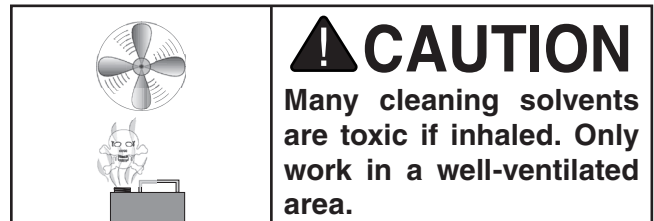
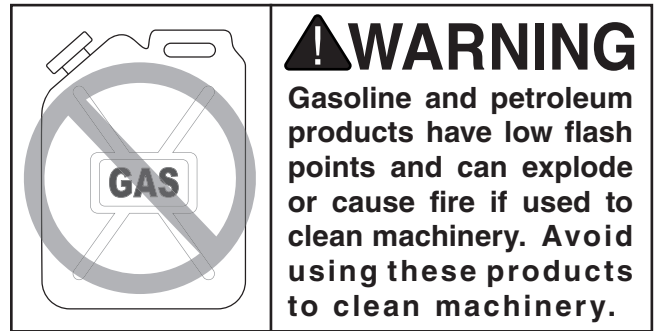

T23692—Orange Power Degreaser

A great product for removing the waxy shipping grease from the *non-painted* parts of the machine during clean up.



Figure 5. T23692 Orange Power Degreaser.



Site Considerations

Weight Load

Refer to the **Machine Data Sheet** for the weight of your machine. Make sure that the surface upon which the machine is placed will bear the weight of the machine, additional equipment that may be installed on the machine, and the heaviest workpiece that will be used. Additionally, consider the weight of the operator and any dynamic loading that may occur when operating the machine.

Space Allocation

Consider the largest size of workpiece that will be processed through this machine and provide enough space around the machine for adequate operator material handling or the installation of auxiliary equipment. With permanent installations, leave enough space around the machine to open or remove doors/covers as required by the maintenance and service described in this manual. **See below for required space allocation.**

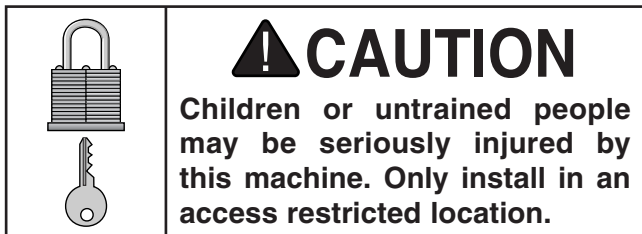

Physical Environment

The physical environment where the machine is operated is important for safe operation and longevity of machine components. For best results, operate this machine in a dry environment that is free from excessive moisture, hazardous chemicals, airborne abrasives, or extreme conditions. Extreme conditions for this type of machinery are generally those where the ambient temperature range exceeds 41°–104°F; the relative humidity range exceeds 20%–95% (non-condensing); or the environment is subject to vibration, shocks, or bumps.

Electrical Installation

Place this machine near an existing power source. Make sure all power cords are protected from traffic, material handling, moisture, chemicals, or other hazards. Make sure to leave enough space around machine to disconnect power supply or apply a lockout/tagout device, if required.

Lighting

Lighting around the machine must be adequate enough that operations can be performed safely. Shadows, glare, or strobe effects that may distract or impede the operator must be eliminated.

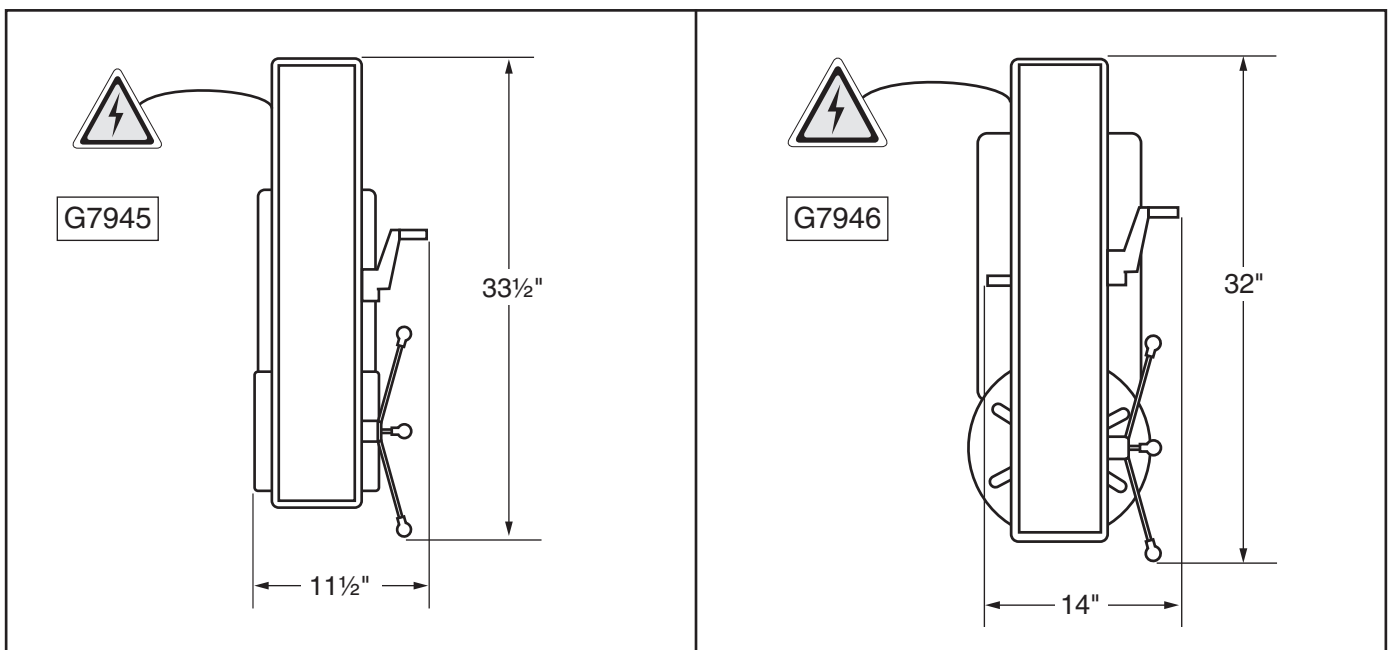

Figure 6. Working clearances.



Mounting to Workbench (G7945)

To prevent tipping injury or loss of control, the Model G7945 must be secured to a workbench, tool table, or other stable surface.

The strongest mounting option is a "Through Mount" (see example below) where holes are drilled all the way through the workbench—and hex bolts, washers, and hex nuts are used to secure the machine in place.

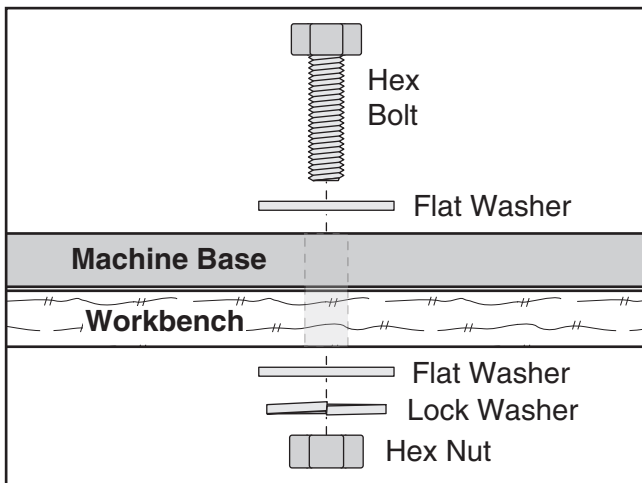

Figure 7. "Through Mount" setup.

Another option is a "direct mount" (see example below) where the machine is secured directly to the workbench with lag screws and washers.

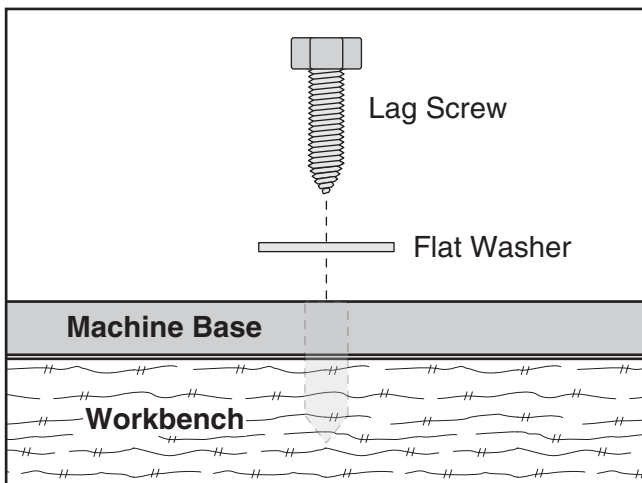

Figure 8. "Direct Mount" setup.

Anchoring to Floor (G7946)

Number of Mounting Holes 4
 Diameter of Mounting Hardware..... 1/2"

Anchoring machinery to the floor prevents tipping or shifting and reduces vibration that may occur during operation, resulting in a machine that runs slightly quieter and feels more solid.

Anchoring to Concrete Floors

Lag shield anchors with lag screws (see below) are a popular way to anchor machinery to a concrete floor, because the anchors sit flush with the floor surface, making it easy to unbolt and move the machine later, if needed. However, anytime local codes apply, you MUST follow the anchoring methodology specified by the code.

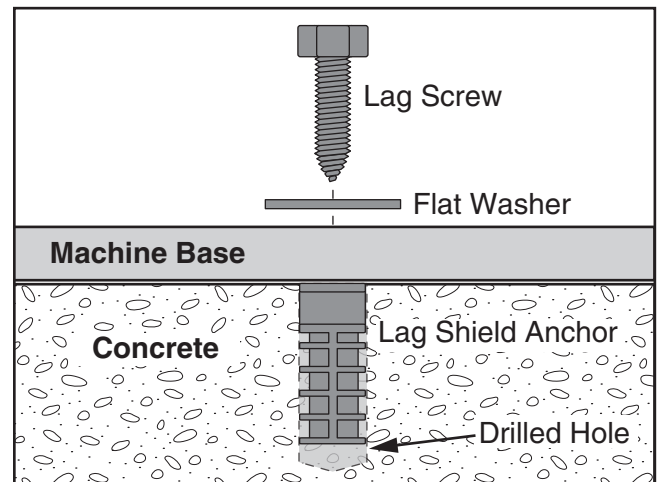

Figure 9. Popular method for anchoring machinery to a concrete floor.



Mounting to Mobile Base (G7946)

Because the drill press is top-heavy by nature, we recommend mounting it to the floor, rather than a mobile base.

If you must use a mobile base, ALWAYS mount your drill press to a base plate inside of the mobile base, as shown in **Figure 10**.

A good quality base plate increases the standard footprint of the drill press to make it much more stable. The base plate must be at least 1½" thick and made of plywood (do not use OSB, MDF, or particle board) to hold the weight of the drill press. A common way for making the baseplate is described in this sub-section.

Always use extreme care when moving the drill press around with the mobile base!

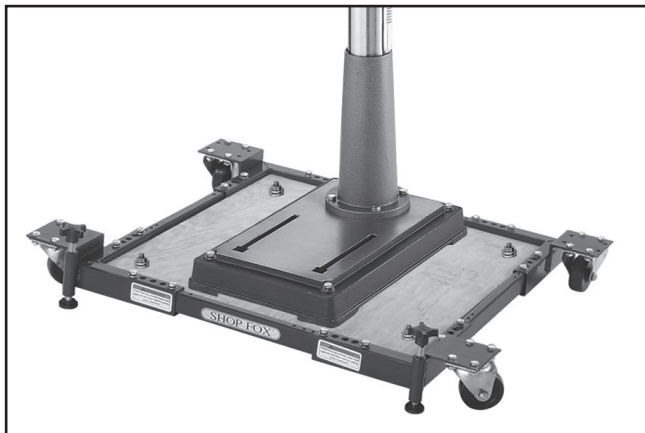

Figure 10. Drill press mounted on mobile base, using a base plate for support.

⚠ CAUTION

Drill presses are top-heavy and must be securely attached to a large-footprint base plate when used with a mobile base. Failure to use a base plate greatly increases possibility of tipping and personal injury.

Items Needed	Qty
Plywood ¾" x 23¾" x 23¾"	2
Wood Glue.....	As Needed
Wood Screws #6 x 1¼"	24
Hex Bolts (2¼" Long, Sized for Base Plate)	4
Hex Nuts (Sized for Hex Bolts).....	4
Lock Washers (Sized for Hex Bolts).....	4
Flat Washers (Sized for Hex Bolts)	8
Assistant to Lift Drill Press	1

To make and use the base plate:

1. Glue the two pieces of plywood together, aligning edges and corners to make one thick piece.
2. Use wood screws to secure boards together from both sides.
3. Allow 24 hours for glue to dry before mounting drill press.
4. Place plywood base plate on mobile base.
5. Drill holes through base plate and metal plates at mobile base corners.
6. Secure base plate to mobile base with hex bolts, hex nuts, flat washers and lock washers, as shown in **Figure 11**.

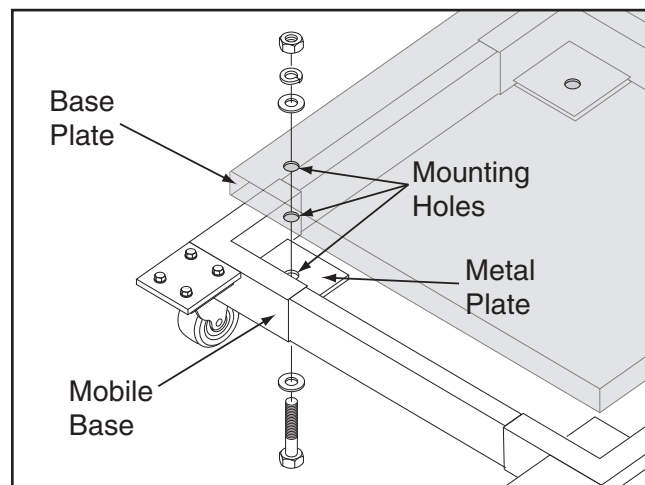

Figure 11. Mounting base plate to mobile base.



7. With help of an assistant, place drill press on base plate.
8. Position drill press close to front of mobile base, so mobile base will not become a tripping hazard.
9. Mount drill press to base plate with lag bolts and flat washers, as shown in **Figure 12**, or with through bolts, flat washers, and hex nuts.

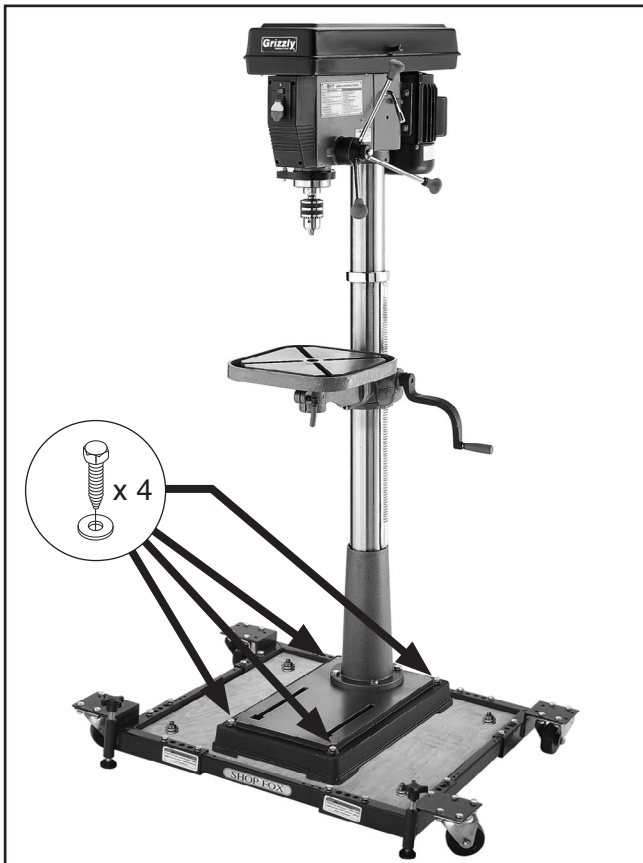

Figure 12. Drill press bolted to mobile base, using lag bolts and flat washers.

Assembly

The machine must be fully assembled before it can be operated. Before beginning the assembly process, refer to **Needed for Setup** and gather all listed items. To ensure the assembly process goes smoothly, first clean any parts that are covered or coated in heavy-duty rust preventative (if applicable).

To assemble the machine:

1. Place the column on the base and align the mounting holes.
2. Secure the column to the base with the four hex bolts, as shown in **Figure 13**.

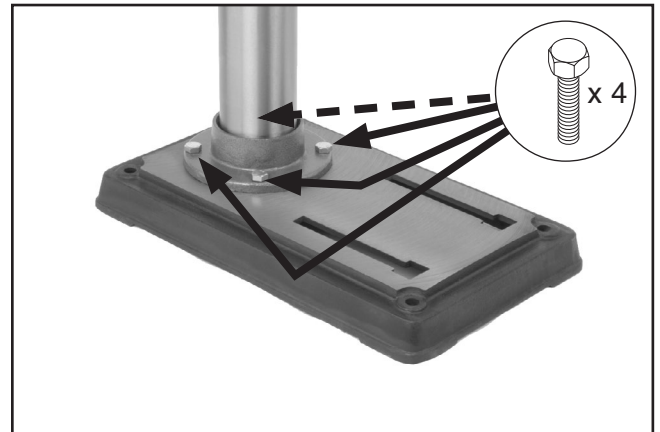

Figure 13. Column secured to base.

3. Check to make sure the pinion gear is fully inserted into the hole on the side of the table bracket shown in **Figure 14**.

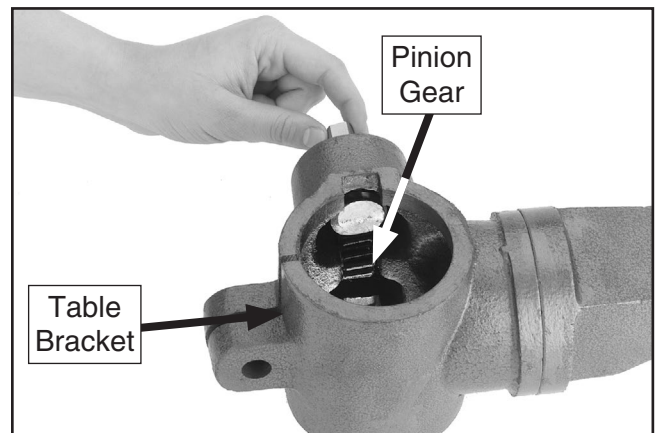

Figure 14. Pinion gear position.



4. Slide the crank arm over the pinion gear shaft and align the set screw in the crank arm with the flat portion of the shaft (see **Figure 15**).
5. Thread the handle into the crank arm.
6. Remove column ring (**Figure 16**) by loosening set screw and remove rack (**Figure 15**). The end of the rack that has teeth extending closest to the edge must be positioned down.
7. Insert rack into table bracket pocket so gear teeth mesh with rack as shown in **Figure 15**.

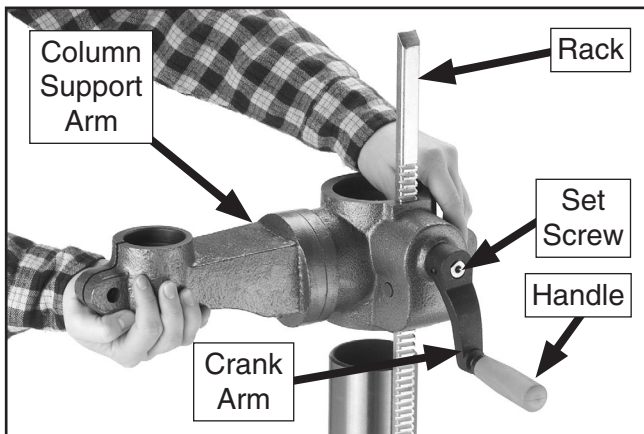

Figure 15. Rack orientation (G7946 shown).

8. Slide table bracket and rack over column. Let them slide down column until bottom of rack contacts shoulder of column support.
9. Slide the column ring over the column with the beveled edge facing down (see **Figure 16**), fit the beveled edge of the column ring over the rack, and tighten the set screw.

Note: Do not overtighten the set screw or you may split the column ring. Also make sure the rack is seated firmly in the lower ring.

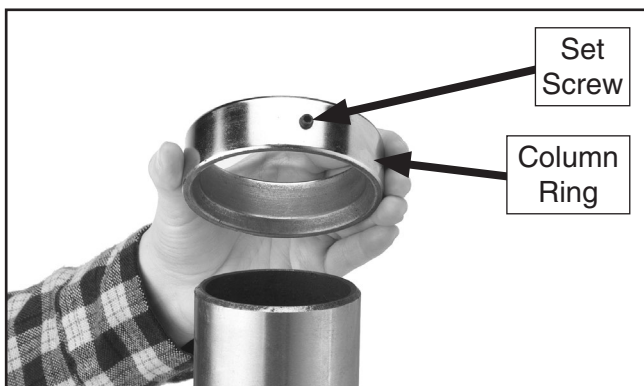

Figure 16. Inside bevel in the correct position.

10. Thread the large lock lever into the non-threaded side on the back of the column support arm about three turns, for now.
11. (**G7946 Only**): Install the table support arm onto the column support arm, then install the table (see **Figure 17**).

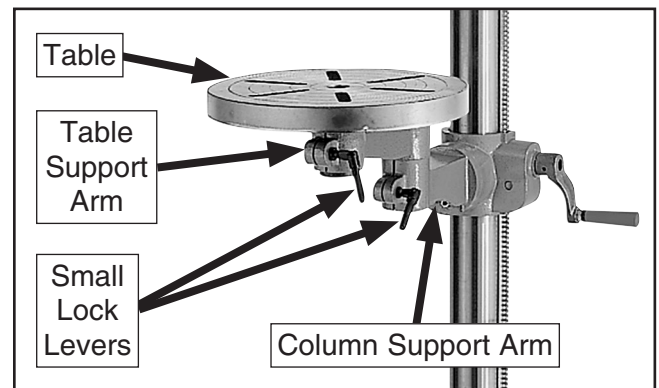

Figure 17. Model G7946 table assembly.

12. Thread a small lock lever into the non-threaded side on the table support arm and column support arm about three turns for now (see **Figure 17**).
13. Insert the included lock shoe into the recessed pocket on the inside of the headstock opening as shown in **Figure 18**.

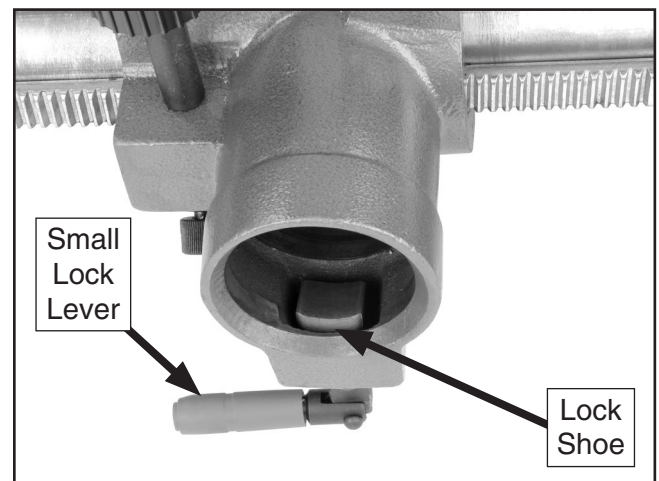



Figure 18. Lock shoe installed.





⚠ CAUTION
The headstock is a heavy load. Seek assistance before beginning this step.

14. With the help of an assistant, lift the headstock over the top end of the column. When the underside of the headstock is lined up with the column, slide the headstock onto the column until it stops (approximately 2").

Note: An alternate method is to lay the headstock and column on the floor, slide them together, tilt the assembly up, and position the drill press upright on its base.

15. Screw two small lock levers into each side of horizontal column bracket (see **Figure 19**).

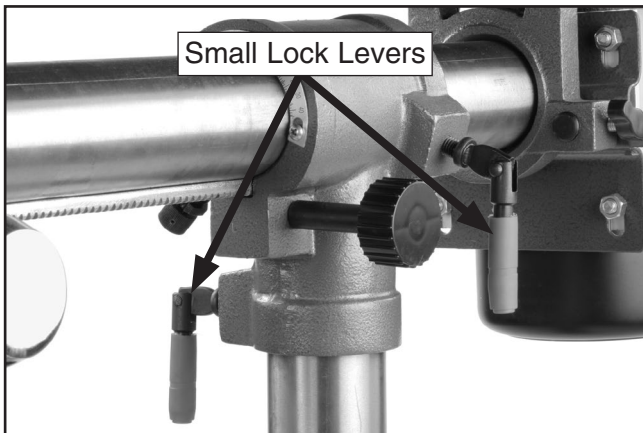

Figure 19. Small lock levers installed.

16. Tightly thread the downfeed handles into the hub as shown in **Figure 20**.

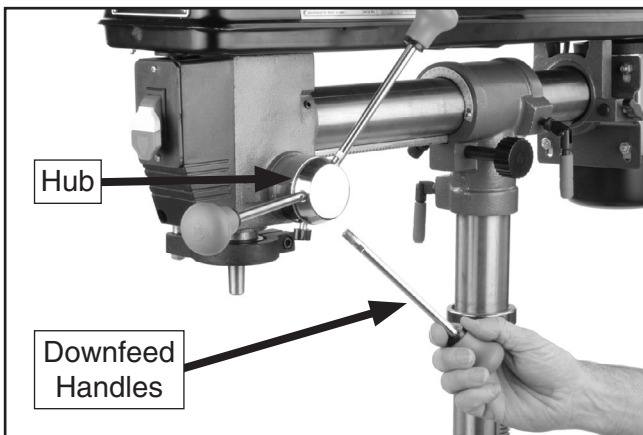

Figure 20. Installing downfeed handles.

17. Slide chuck guard onto bottom of depth-stop bracket, as shown in **Figure 21**.

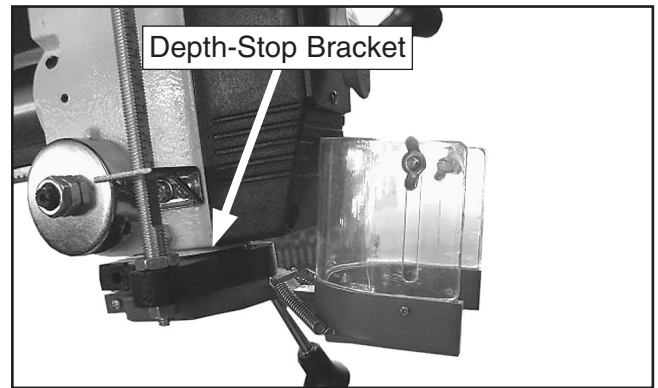

Figure 21. Chuck guard installed on depth-stop bracket.

18. Secure chuck guard to bracket with (4) M4-.7 x 10 Phillips head screws and (4) 4mm flat washers, as shown in **Figure 22**.

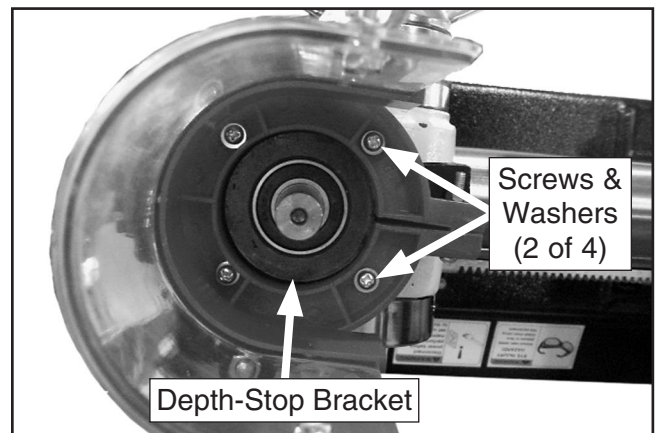

Figure 22. Chuck guard secured to depth stop bracket.



Joining Drill Chuck & Arbor

The drill chuck is attached to the drill spindle by means of a machined taper between the chuck and spindle nose. An almost permanent assembly is created when properly joined.

IMPORTANT: DO NOT install the drill chuck until **AFTER** the test run.

To assemble the drill chuck and mount it to the spindle, carefully follow the instructions below:

1. Use mineral spirits to thoroughly clean the drill chuck, arbor, and spindle sockets and dry all surfaces before assembly.
2. Use the chuck key provided to adjust the jaws of the chuck until they are well inside the drill chuck body.
3. Slide the chuck onto the spindle end and tap the drill chuck with a rubber or wooden mallet to seat it as shown in **Figure 23**.

CAUTION

DO NOT use a steel hammer on the drill chuck to seat it onto the spindle. **Damage will occur to the chuck and/or spindle which may make them unusable or unsafe.**



Figure 23. Seating chuck into spindle. (Note retracted jaws.)



Test Run

Once assembly is complete, test run the machine to ensure it is properly connected to power and safety components are functioning correctly.

If you find an unusual problem during the test run, immediately stop the machine, disconnect it from power, and fix the problem **BEFORE** operating the machine again. The **Troubleshooting** table in the **SERVICE** section of this manual can help.

The Test Run consists of verifying the following:
1) The motor powers up and runs correctly, and
2) the safety disabling mechanism on the switch works correctly.

!WARNING

Serious injury or death can result from using this machine BEFORE understanding its controls and related safety information. DO NOT operate, or allow others to operate, machine until the information is understood.

!WARNING

DO NOT start machine until all preceding setup instructions have been performed. Operating an improperly set up machine may result in malfunction or unexpected results that can lead to serious injury, death, or machine/property damage.

To test run the machine:

1. Clear all setup tools away from machine.
2. Connect machine to power supply.
3. Turn machine **ON**, verify motor operation, and then turn machine **OFF**.

The motor should run smoothly and without unusual problems or noises.

4. Remove switch disabling key, as shown in **Figure 24**.

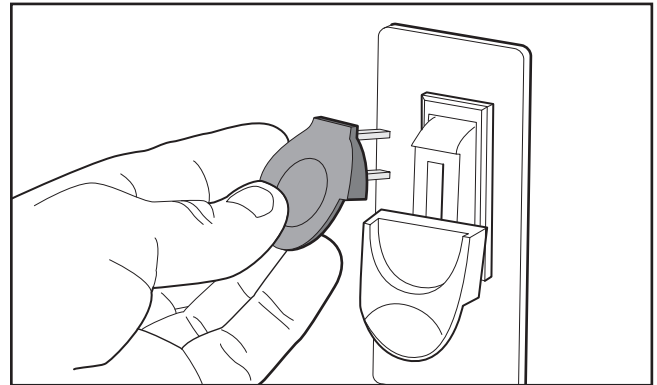

Figure 24. Removing switch key from paddle switch.

5. Try to start machine with paddle switch. The machine should not start.
 - If the machine *does not* start, the switch disabling feature is working as designed.
 - If the machine *does start*, immediately stop the machine. The switch disabling feature is not working correctly. This safety feature must work properly before proceeding with regular operations. Call Tech Support for help.



Spindle Break-In

The spindle break-in procedure distributes lubrication throughout the bearings to reduce the risk of early bearing failure if there are any "dry" spots or areas where lubrication has settled in the bearings. You **must** complete this procedure **before** placing operational loads on the spindle for the first time when the machine is new or if it has been sitting idle for longer than 6 months.

Always start the spindle break-in at the lowest speed to minimize wear if there *are* dry spots. Allow the spindle to run long enough to warm up and distribute the bearing grease, then incrementally increase spindle speeds and repeat this process at each speed until reaching the maximum spindle speed. Following the break-in procedure in this progressive manner helps minimize any potential wear that could occur before lubrication is fully distributed.

NOTICE

Complete spindle bearing break-in procedure to prevent rapid wear and tear of spindle components once drill press is placed into operation.

To perform spindle break-in:

1. Make sure spindle area is free of obstructions.
2. Configure V-belt for a spindle speed of 550 RPM. Refer to **Changing Spindle Speed** on **Page 28**.
3. Connect machine to power and run spindle for 10 minutes.
4. Turn machine **OFF**, allow spindle to come to a complete stop, then **DISCONNECT MACHINE FROM POWER!**
5. Configure V-belt for spindle speed of 950 RPM (refer to **Changing Spindle Speed** on **Page 28**), then connect machine to power.
6. Run spindle for 5 minutes at 950 RPM.
7. Repeat Steps **4–6** for each speed listed below in progressive order.
 - a. 1610 RPM
 - b. 2230 RPM
 - c. 3000 RPM
8. Turn machine **OFF**.

Congratulations! Spindle break-in is now complete.



SECTION 4: OPERATIONS

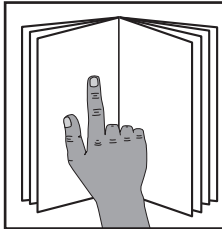

!WARNING

To reduce your risk of serious injury, read this entire manual **BEFORE** using machine.

!WARNING

To reduce risk of eye or face injury from flying chips, always wear approved safety glasses and a face shield when operating this machine.

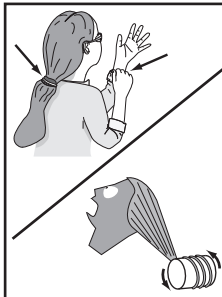
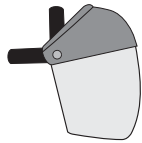

!WARNING

Keep hair, clothing, and jewelry away from moving parts at all times. Entanglement can result in death, amputation, or severe crushing injuries!

NOTICE

If you are not experienced with this type of machine, **WE STRONGLY RECOMMEND** that you seek additional training outside of this manual. Read books/magazines or get formal training before beginning any projects. Regardless of the content in this section, Grizzly Industrial will not be held liable for accidents caused by lack of training.

Operation Overview

The purpose of this overview is to provide the novice machine operator with a basic understanding of how the machine is used during operation, so the machine controls/components discussed later in this manual are easier to understand.

Due to the generic nature of this overview, it is **not** intended to be an instructional guide. To learn more about specific operations, read this entire manual, seek additional training from experienced machine operators, and do additional research outside of this manual by reading "how-to" books, trade magazines, or websites.

To complete a typical operation, the operator does the following:

1. Examines workpiece to make sure it is suitable for drilling.
2. Puts on required safety glasses and face shield.
3. Firmly secures workpiece to table using a vise or T-slot clamps.
4. Installs correct cutting tool for operation.
5. Adjusts table to correct height, then locks it in place.
6. Selects appropriate spindle speed according to V-belt configuration chart located inside belt cover.
7. Connects machine to power, and turns machine **ON**.
8. Performs drilling operation.
9. When finished, turns machine **OFF** and disconnects it from power.



Choosing Speeds

Using the Drill Bit Speed Chart

The chart shown in **Figure 25** is intended as a guide only. Always follow the manufacturer's speed recommendations if provided with your drill bits, cutters, or hole saws. Exceeding the recommended speeds may be dangerous to the operator.

The speeds shown here are intended to get you started. The optimum speed will always depend on various factors, including tool diameter, drilling pressure, material hardness, material quality, and desired finish.

Often, when drilling materials other than wood, some type of lubrication is necessary.

Lubrication Suggestions

Wood/Cast Iron.....None
 PlasticsSoapy Water
 BrassWater-Based Lubricant
 Aluminum..... Paraffin-Based Lubricant
 Mild Steel..... Oil-Based Lubricant

CAUTION

Larger bits turning at slower speeds tend to grab the workpiece aggressively. This can result in the operator's hand being pulled into the bit or the workpiece being thrown with great force. Always clamp the workpiece to the table to prevent injuries.

Twist/Brad Point Drill Bits	Soft Wood	Hard Wood	Plastic	Brass	Aluminum	Mild Steel
1/16" – 3/16"	3000	2500	2500	2500	3000	2500
13/64" – 3/8"	2000	1500	2000	1250	2500	1250
25/64" – 5/8"	1500	750	1500	750	1500	600
11/16" – 1"	750	500	1000	400	1000	350

Spade/Forstner Bits	Soft Wood	Hard Wood	Plastic	Brass	Aluminum	Mild Steel
1/4" – 1/2"	2000	1500				
9/16" – 1"	1500	1250				
1-1/8" – 1-7/8"	1000	750				
2–3"	500	350				

Hole Saws	Soft Wood	Hard Wood	Plastic	Brass	Aluminum	Mild Steel
1/2" – 7/8"	500	500	600	600	600	500
1" – 1-7/8"	400	400	500	500	500	400
2" – 2-7/8"	300	300	400	400	400	300
3" – 3-7/8"	200	200	300	300	300	200
4" – 5"	100	100	200	200	200	100

Rosette Cutters	Soft Wood	Hard Wood	Plastic	Brass	Aluminum	Mild Steel
Carbide Insert Type	350	250				
One-Piece Type	1800	500				

Tenon/Plug Cutters	Soft Wood	Hard Wood	Plastic	Brass	Aluminum	Mild Steel
3/8" – 1/2"	1200	1000				
5/8" – 1"	800	600				

Figure 25. Drill bit speed chart.



Changing Spindle Speed

The belt in the head of the drill press must be rearranged to change speeds. A chart under the pulley cover shows the belt positions needed to make the drill press run at each available speed.

To change speed:

1. DISCONNECT MACHINE FROM POWER!
2. Loosen belt-tension lock knobs (shown in **Figure 26**) on both sides of the headstock, and move motor toward chuck.

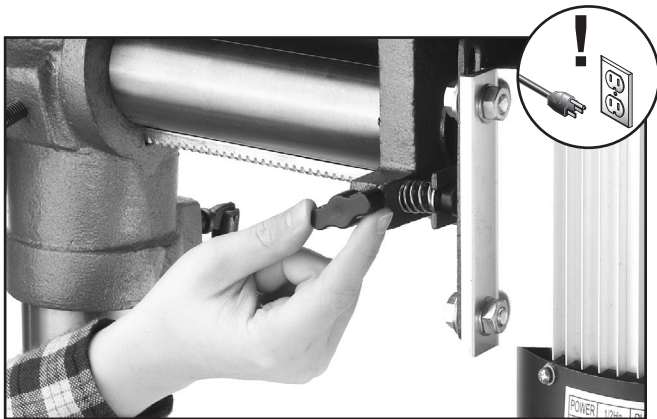

Figure 26. Example of loosening belt-tension lock knob (1 of 2).

3. Locate desired speed on the speed chart under the pulley cover, and move the V-belt to the desired pulley grooves.

—If V-belt is cracked, torn, excessively worn, or damaged, replace it.

4. Move the motor toward the back of the headstock and tighten the lock knobs once the desired V-belt tension is achieved.
5. Close the belt cover before connecting the machine to power.

WARNING

Never operate drill press with pulley cover in the open position. You can get entangled in belt/pulleys and serious personal injury may occur.

Drilling

The Model G7945/G7946 is designed for drilling holes in wood, plastic, and metal. The basic operation of a drill press is lining up your drill bit with the intended hole location, turning the drill press **ON**, and using the down feed levers to move the spinning drill bit into the workpiece.

For safe operation and optimum results, it is very important to follow these guidelines when drilling:

CLEARING CHIPS: Raise the drill bit often to clear chips and cool the drill bit. This will ease the work of the drill press motor and extend the life of your drill bits.

SECURING WORKPIECE TO TABLE: Secure the workpiece to the table or in a vise that is secured to the table before drilling.

PROTECTING TABLE: Protect the table by placing the workpiece on scrap wood, or center the location of the hole to be drilled over the pocket in the table when through drilling. Also, make use of the depth stop so that the drill bit goes no deeper than necessary.

USING CORRECT SPEEDS: Use the correct speed for the diameter of the drill bit being used and the type of material being drilled. Refer to the **Drill Bit Speed Chart** on **Page 27** to help you choose the correct speed for your application.

LARGE DIAMETER BITS: Large diameter drill bits require slower spindle speeds.

SMALL DIAMETER BITS: Smaller diameter drill bits require faster spindle speeds.

HARD MATERIAL: Harder materials (steel vs. wood) require slower drilling speeds.

SOFT MATERIAL: Soft materials require a faster drilling speed. (**NOTE:** Plastics can melt at too high of a spindle speed!)

LUBRICANT: Use lubricant on all materials except wood and cast iron. Refer to **Lubrication Suggestions** on **Page 27** to find the correct lubrication for your application.



DRILLING ACCURACY: To prevent drill bit wandering and ensure accurate placement of holes, mark the hole location with a center punch before drilling. Also consider using a center-point drill to start the hole.

PLUG/ROSETTE CUTTERS: Plug cutters and rosette cutters are for wood only.

5-FLUTE/2-FLUTE CUTTERS: Use a 5-flute cutter when cutting into plastics, brass, aluminum, and mild steel. A 2-flute cutter can aggressively grab the workpiece and damage the tool if used with materials other than wood.

SPADE BITS AND PLASTIC: When drilling plastic with a spade bit, use a spade bit with spurs.

HOLE SAWS: When using hole saws, apply firm and even pressure, so the saw teeth contact the surface all at the same time—not at an angle. You can also flip the workpiece and finish drilling from the other side.

CAUTION

Larger bits turning at slower speeds tend to grab the workpiece aggressively. This can result in the operator's hand being pulled into the bit or the workpiece being thrown with great force. Always clamp the workpiece to the table to prevent injuries.

Installing/Removing Drill Bits

Any drill bit you install in the chuck must be tight enough that it will not come loose during operation.

Installing a Drill Bit

1. DISCONNECT MACHINE FROM POWER!
2. Open the drill chuck wide enough to accept the shank of the drill bit.
3. Insert the drill bit as far as possible into the chuck WITHOUT allowing the chuck jaws to touch the fluted portion of the bit, and hand-tighten the chuck.

Note: *Make sure small bits are not trapped between the edges of two jaws; if they are, reinstall the drill bit or it will not be secure enough to use for drilling.*

4. Final-tighten the drill bit with the chuck key.

Removing a Drill Bit

1. DISCONNECT MACHINE FROM POWER!
2. Use the chuck key to open the drill chuck, and catch the drill bit with a rag to protect your hands.



Adjusting Depth Stop

The Model G7945/G7946 has a depth stop that allows you to drill repeated non-through holes to the same depth every time.

The depth stop consists of a stud attached to the quill with two hex nuts that can be lowered or raised on the stud so the lower nut (depth nut) hits a stop bracket when the drill bit is lowered. The upper hex nut (jam nut) is then used to tighten against the depth nut to secure it in place so it doesn't move with repeated operations. **Figure 27** shows the various components of the depth stop.

The return height nut, on the base of the stud, limits the downfeed handle return distance, which is set by how high the nut is placed on the stud. This feature is useful for repetitive drilling motions.

Note: The scale on the depth stop can be recalibrated if it gets moved or has changed since the factory setting. Refer to **Depth Stop Calibration** on **Page 38** for instructions on how this is done.

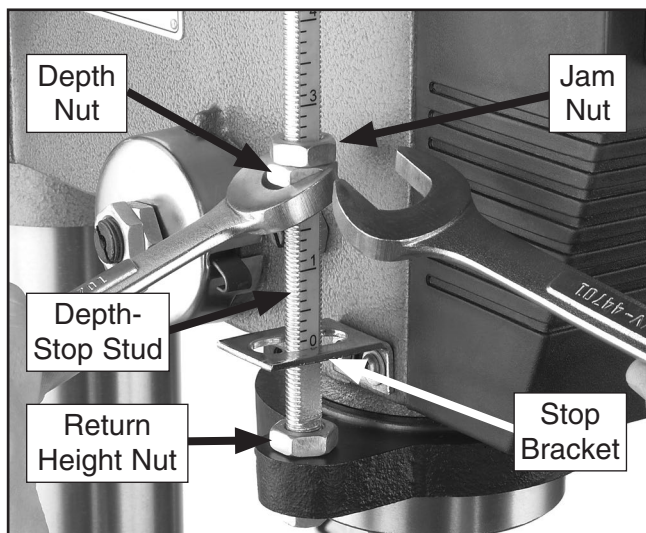

Figure 27. Depth stop components.

Setting Depth Stop

1. Lower the drill bit to the required height.
2. Thread the depth nut down against the stop bracket.
3. Lower the jam nut against the depth nut.
4. Using wrenches, hold the depth nut in place and tighten the jam nut against the depth nut.

Setting Spindle Return Distance

1. Lower the drill bit.
2. Thread the return height nut up the stud to the desired height.

Adjusting Table

The Model G7945 table can be adjusted for height and tilt. The G7946 table features the same types of adjustments but can also be rotated and adjusted for distance from the column.

Adjusting Table Height

1. Loosen the table bracket lock lever (see **Figure 28**). Turn the table crank to raise or lower the table.
2. Remember to lock the support bracket in place before operating the machine.

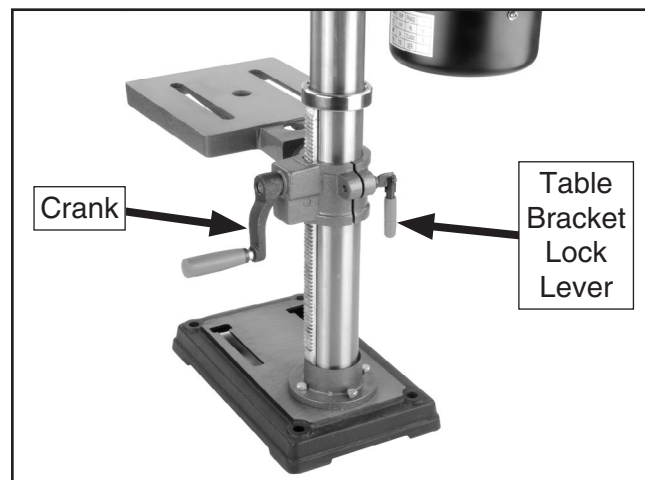

Figure 28. Table height controls (G7945).



Adjusting Table Tilt

1. **(G7946 Only):** Turn the locating pin nut (see **Figure 29**) in a clockwise direction. This will draw the locating pin out of the casting. Once loose, pull out the pin and nut, and set them in a safe place until needed.

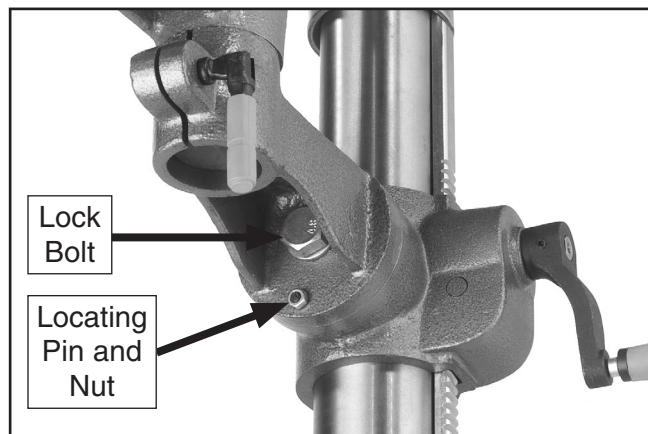

Figure 29. Table tilt locating pin and nut and lock bolt for angle adjustment (G7946).

2. Loosen the lock bolt (**Figure 30**) using the included wrench and tilt the table (G7945) or the column support arm (G7946) to the desired angle.

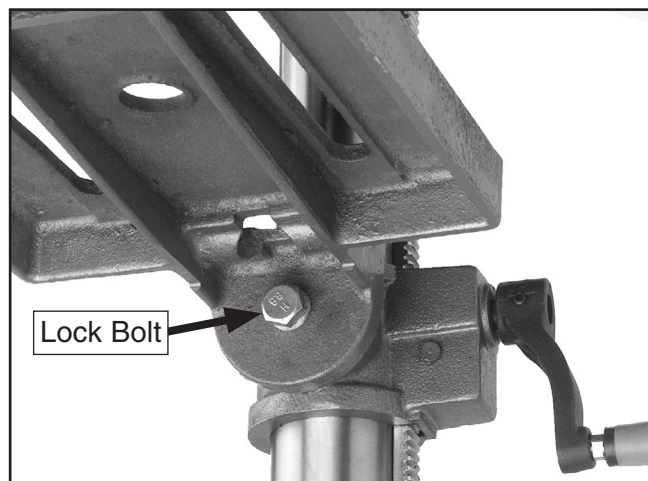

Figure 30. Table tilt lock bolt for angle adjustment (G7945).

3. Lock in place by tightening the lock bolt.
4. **(G7946 Only):** To return the table to its original position, align the holes in the column support arm and table bracket, insert the locating pin and nut, and gently tap the pin with a hammer.
5. Tighten the locating pin nut.

Model G7945/G7946 (Mfd. Since 10/23)

Adjusting Table Rotation (G7946 Only)

1. Loosen the lock lever located under the table (see **Figure 31**). Rotate the table the desired amount.
2. Always lock the table support arm in place before operating the machine.

Adjusting Distance from Column (G7946 Only)

1. Loosen the lock lever located at the pivoting elbow of the table support (see **Figure 31**).

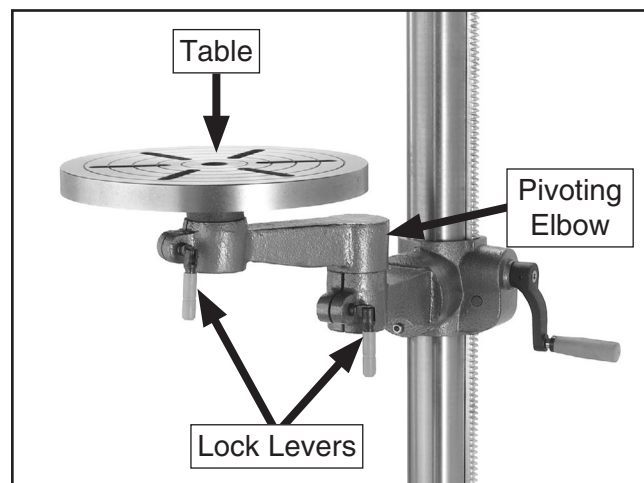

Figure 31. Adjusting distance from column.

2. Swing the table support to the desired distance from the column. The support bracket may need to be rotated around the column to keep the table centered under the chuck. Secure all lock levers before operating the machine.



Adjusting Headstock

The headstock can be tilted from 45° clockwise to 90° counterclockwise when the headstock lock pin is released.

The lock pin functions as a quick way to re-set the spindle 90° to the table after it has been tilted.

Tilting Headstock

1. Loosen the lock lever on the right side of the headstock (see **Figure 32**).

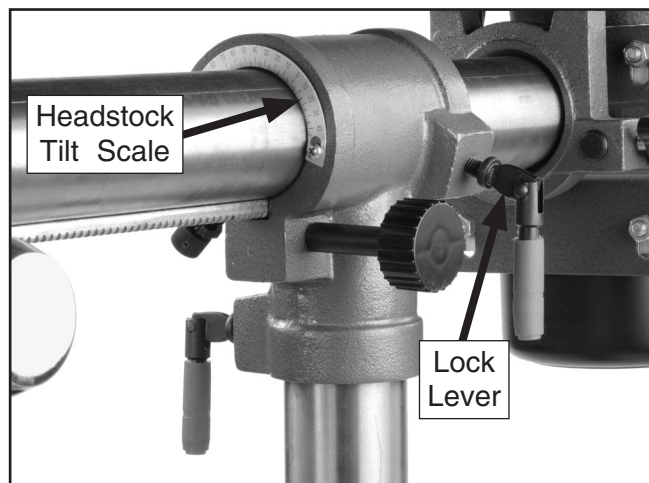

Figure 32. Headstock lock lever and rotation scale.

2. Pull out the lock pin located on the left side of the headstock and rotate the pin 90° as shown in **Figure 33**.

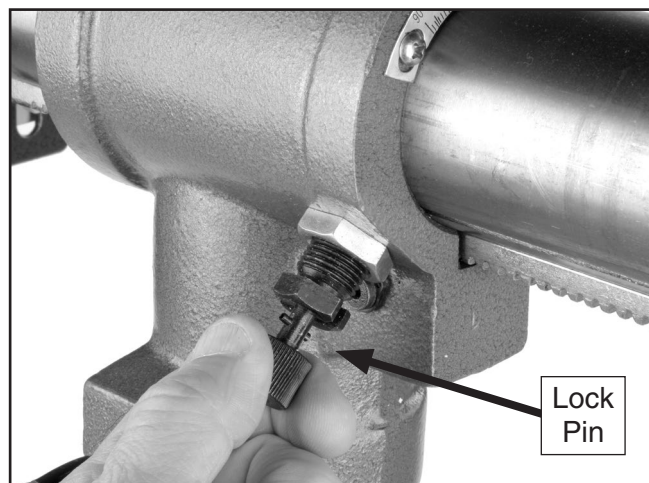

Figure 33. Lock pin location.

3. Tilt the headstock to the desired angle on the scale and tighten the lock lever on the right side of the headstock (see **Figure 32**).

Returning Head to Vertical Position

1. Loosen the lock lever located on the right side of the headstock (see **Figure 32**).
2. Move the lock pin back into the guide slot. (see **Figure 33**)
3. Return the headstock to the vertical position. The headstock lock pin should lock into place.

Note: The lock pin is only intended to be a rough indexing tool.

4. For finer adjustments, align the zero mark on the headstock scale with the line on the horizontal column.
5. Tighten the lock lever.

Adjusting Headstock Forward/Backward

1. Loosen the lock lever located on the right side of the headstock (see **Figure 34**).
2. Turn the adjustment knob (see **Figure 34**) to move the headstock forward/backward to the desired position.

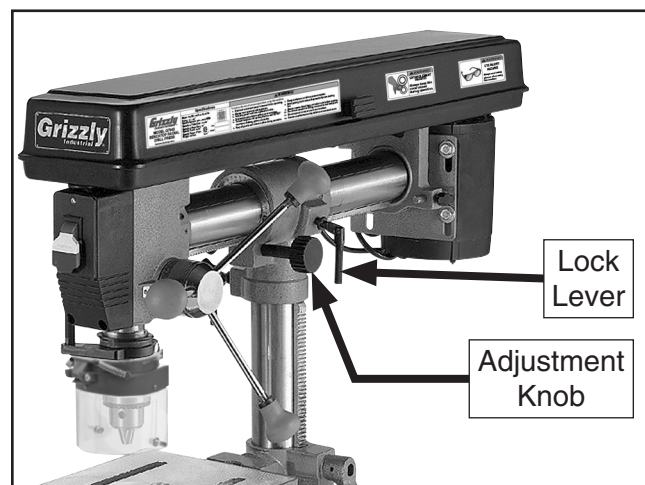

Figure 34. Controls for forward/backward headstock travel.

3. Tighten the lock lever.



SECTION 5: ACCESSORIES

!WARNING

Installing unapproved accessories may cause machine to malfunction, resulting in serious personal injury or machine damage. To reduce this risk, only install accessories recommended for this machine by Grizzly.

NOTICE

Refer to our website or latest catalog for additional recommended accessories.

G8581—1/2" Keyless Drill Chuck JT33

Industrial-grade keyless chucks are excellent for quick bit changes. Knurled grips and exceptional accuracy make these chucks an indispensable part of any shop. Use on drill presses, lathe tailstocks and milling machines. 0 – 1/2" capacity with a Jacobs Taper #33 in back.



Figure 35. Model G8581 1/2" Keyless Drill Chuck.

G2500—20-Pc. Regular Sanding Drum Set

Use on your drill press, lathe, or hand drill. This kit consists of 5 drums in popular 1/2" x 1/2", 3/4" x 1", 1" x 1", 1 1/2" x 1 1/2", and 2" x 1 1/2" sizes. Comes with 50-, 80-, and 120-grit sizes for each drum.



Figure 36. Model G2500 20-Pc. Regular Sanding Drum Set.

Recommended Metal Protectants

G5562—SLIPIT® 1 Qt. Gel

G5563—SLIPIT® 11 Oz. Spray

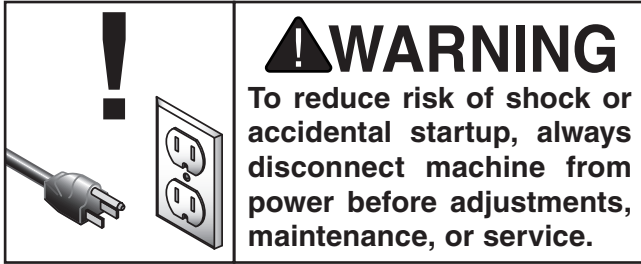

Figure 37. Recommended products for protecting unpainted cast iron/steel parts on machinery.

order online at www.grizzly.com or call 1-800-523-4777



SECTION 6: MAINTENANCE



General

For optimum performance from this machine, this maintenance schedule must be strictly followed.

Ongoing

To minimize your risk of injury and maintain proper machine operation, shut down the machine immediately if you ever observe any of the items below, and fix the problem before continuing operations:

- Loose mounting bolts.
- Worn switch.
- Worn or damaged wires.
- Damaged V-belt.
- Any other unsafe condition.

Monthly Check

- V-belt tension, damage, or wear.
- Clean/vacuum dust buildup off motor.

Cleaning & Protecting

Cleaning the Model G7945/G7946 is relatively easy. Vacuum excess wood chips and sawdust, and wipe off the remaining dust with a dry cloth. If any resin has built up, use a resin-dissolving cleaner to remove it.

Protect the unpainted cast-iron table by wiping it clean after every use—this ensures moisture from wood dust does not remain on bare metal surfaces. Keep the table rust-free with regular applications of products like SLIPIT® (see **Page 33** for more details).

Lubrication

Since all bearings are shielded and permanently lubricated, simply leave them alone until they need to be replaced. **DO NOT** lubricate them.

Keep quill, spindle, column, and table top well lubricated to prevent rust.

V-Belt

Inspect regularly for tension and wear. Check pulleys to ensure that they are properly aligned. See **Changing Speeds** on **Page 28** for more information about removing/installing belts if you need help replacing the belts.



SECTION 7: SERVICE

Review the troubleshooting procedures in this section if a problem develops with your machine. If you need replacement parts or additional help with a procedure, call our Technical Support. **Note:** *Please gather the serial number and manufacture date of your machine before calling.*

Troubleshooting



Motor & Electrical

Symptom	Possible Cause	Possible Solution
Machine does not start, or power supply breaker immediately trips after startup.	<ol style="list-style-type: none"> 1. Switch disabling key removed. 2. Incorrect power supply voltage or circuit size. 3. Power supply circuit breaker tripped or fuse blown. 4. Motor wires connected incorrectly. 5. Wiring open/has high resistance. 6. Start capacitor at fault. 7. Wiring broken, disconnected, or corroded. 8. Motor or motor bearings at fault. 	<ol style="list-style-type: none"> 1. Install switch disabling key. 2. Ensure correct power supply voltage and circuit size (Page 12). 3. Ensure circuit is free of shorts. Reset circuit breaker or replace fuse. 4. Correct motor wiring connections (Page 40). 5. Check/fix broken, disconnected, or corroded wires. 6. Test/replace if at fault. 7. Fix broken wires or disconnected/corroded connections (Page 40). 8. Replace motor.
Machine stalls or is underpowered.	<ol style="list-style-type: none"> 1. Workpiece material unsuitable for machine. 2. Feed rate/cutting speed too fast. 3. Belt slipping/pulleys misaligned. 4. Pulley slipping on shaft. 5. Machine undersized for task. 6. Motor overheated. 7. Extension cord too long. 8. Motor or motor bearings at fault. 	<ol style="list-style-type: none"> 1. Only cut wood/ensure moisture is below 20%. 2. Decrease feed rate/cutting speed (Page 28). 3. Clean/tension/replace belt; ensure pulleys are aligned. 4. Tighten/replace loose pulley/shaft. 5. Use sharp bits/reduce feed rate/reduce spindle RPM (Page 28). 6. Clean motor, let cool, and reduce workload. 7. Move machine closer to power supply; use shorter extension cord (Page 13). 8. Replace motor.
Machine has vibration or noisy operation.	<ol style="list-style-type: none"> 1. Motor or component loose. 2. V-belt worn, loose, pulleys misaligned or belt slapping cover. 3. Pulley loose. 4. Motor mount loose/broken. 5. Spindle loose, improperly installed or damaged. 6. Workpiece loose. 7. Chuck or cutter at fault. 8. Motor fan rubbing on fan cover. 	<ol style="list-style-type: none"> 1. Replace damaged or missing bolts/nuts or tighten if loose. 2. Inspect/replace belt with a new one (Page 28). Realign pulleys if necessary. 3. Secure pulley on shaft. 4. Tighten/replace. 5. Tighten loose spindle, re-install spindle ensuring mating surfaces are clean, replace spindle if damaged. 6. Use the correct holding fixture and reclamp workpiece. 7. Replace unbalanced chuck; replace/resharpen cutter; use correct feed rate. 8. Fix/replace fan cover; replace loose/damaged fan.



Motor & Electrical (Cont.)

Symptom	Possible Cause	Possible Solution
Machine has vibration or noisy operation.	9. Spindle bearings at fault. 10. Motor bearings at fault..	9. Test by rotating spindle; rotational grinding/loose shaft requires bearing replacement. 10. Test by rotating shaft; rotational grinding/loose shaft requires bearing replacement.

Operation

Symptom	Possible Cause	Possible Solution
Tool falls out or loose in chuck.	1. Chuck jaws loose. 2. Excessive feed pressure.	1. Tighten chuck jaws. 2. Decrease feed pressure and allow chips to clear.
Chuck and arbor fall out or loose in spindle.	1. Debris on chuck, arbor, or in spindle taper. 2. Excessive feed pressure.	1. Clean chuck, arbor, and spindle taper, then re-install (Page 23). 2. Decrease feed pressure and allow chips to clear.
Breaking tools or cutters.	1. Spindle speed/feed rate too fast. 2. Taking too big of cut at one time. 3. Improper cutting technique or type of cut for tool/machine. 4. Cutting tool too small. 5. Cutting tool getting too hot. 6. Spindle extended too far down during or at beginning of operation.	1. Reduce spindle speed (Page 28); reduce feed rate. 2. Decrease feed pressure and allow chips to clear. 3. Use right technique, tool, or machine for job. 4. Use larger cutting tool and slower feed rate. 5. Use coolant or oil for appropriate application; reduce cutting speed (Page 28). 6. Fully retract spindle and raise table to increase rigidity.
Workpiece or tool vibrates or chatters during operation.	1. Spindle extended too far down during or at beginning of operation. 2. Table locks not tight. 3. Workpiece not secure. 4. Spindle speed/feed rate too fast.	1. Fully retract spindle and raise table to increase rigidity. 2. Tighten table lock levers (Page 30). 3. Properly clamp workpiece on table or in vise. 4. Reduce spindle speed (Page 28); reduce feed rate.
Table hard to move.	1. Table locked. 2. Dirty or dry rack and pinion.	1. Disengage lock levers (Page 30). 2. Clean away chips/debris.
Backside of workpiece splinters.	1. Scrap board not installed between table and workpiece.	1. Install scrap board between table and workpiece.
Bad surface finish.	1. Spindle speed/feed rate too fast. 2. Dull or incorrect cutting tool/bit. 3. Workpiece not secure. 4. Spindle extended too far down during or at beginning of operation.	1. Reduce spindle speed (Page 28); reduce feed rate. 2. Sharpen cutting tool or select one that better suits operation. 3. Properly clamp workpiece on table or in vise. 4. Fully retract spindle and raise table to increase rigidity.
Spindle overheats.	1. Machine operated at high speeds for extended period.	1. Allow drill to cool.
Spindle does not fully retract.	1. Poorly adjusted return spring. 2. Worn return spring.	1. Increase return spring tension (Page 38). 2. Replace return spring.
Drill bit drifts.	1. Dull/incorrectly sharpened drill bit. 2. Tool/bit incorrectly installed.	1. Correctly sharpen drill bit. 2. Correctly install tool/bit (Page 29).



Operation (Cont.)

Symptom	Possible Cause	Possible Solution
Drill bit slips in chuck or stuck in workpiece.	<ol style="list-style-type: none"> 1. Chuck jaws loose. 2. Workpiece squeezing drill bit. 3. Feed rate too fast. 4. Spindle speed/feed rate too slow. 	<ol style="list-style-type: none"> 1. Tighten chuck jaws. 2. Properly clamp workpiece on table or in vise. 3. Decrease feed rate. 4. Increase spindle speed (Page 28)/feed rate.
Workpiece thrown from table.	<ol style="list-style-type: none"> 1. Workpiece not secure. 2. Tool/bit too large for feed speed. 	<ol style="list-style-type: none"> 1. Properly clamp workpiece in table or in vise. 2. Use smaller tool/bit or decrease feed speed.
Excessive runout or wobbling in chuck/drill bit.	<ol style="list-style-type: none"> 1. Debris on chuck, arbor, or in spindle taper. 2. Tool/bit bent. 3. Tool/bit installed incorrectly. 4. Spindle bearings worn. 	<ol style="list-style-type: none"> 1. Remove chuck and arbor, clean chuck, arbor, and spindle taper, then re-install. Deburr mating surfaces, if necessary. 2. Replace with straight tool/bit. 3. Install tool/bit correctly (Page 29) or replace. 4. Replace spindle bearings.



Calibrating Depth Stop

The drill press comes fitted with a depth stop to use when drilling multiple holes at the same depth. The scale on this depth stop can be calibrated if it ever becomes incorrect.

To calibrate the depth stop:

1. Loosen the return height nut and calibration nut shown in **Figure 38**.

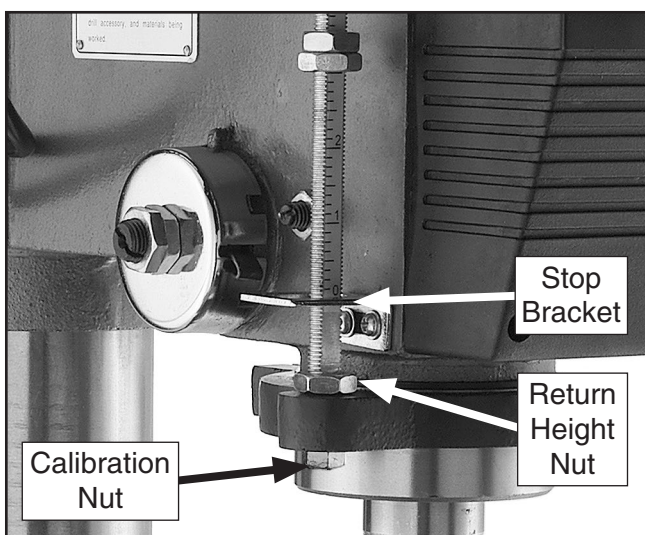

Figure 38. Depth stop assembly.

2. Use the calibration nut to zero the depth stop scale with the stop bracket.
3. Hold the depth stop at zero, and tighten the return height nut to hold the depth stop in position.
4. Test the depth stop by measuring how far the spindle actually moves with respect to where you set the depth stop.

Tensioning Spindle Return Spring

The tension of the spindle return spring makes the spindle automatically return to the top (starting) position when the downfeed handle is released. This spring is pre-adjusted at the factory, and typically will never need further adjustment during the life of the drill press. However, additional tension can be applied if the spindle stops automatically returning to the top position.



Items Needed	Qty
Heavy Leather Gloves	1 Pair
Shop Rags.....	As Needed
Open-End Wrench 24mm.....	1

To adjust the feed shaft spring tension:

1. DISCONNECT MACHINE FROM POWER!
2. Wipe off any oil on the spring lock cover so it does not slip in your fingers when you hold the cover from spinning (see **Figure 39**).

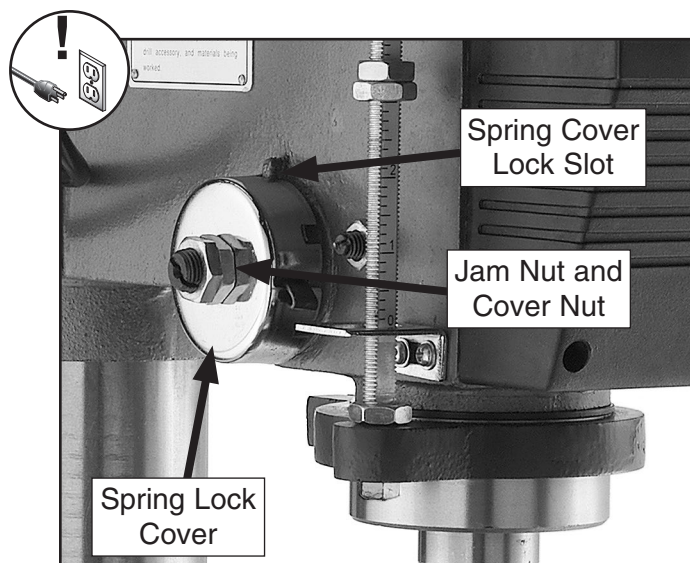

Figure 39. Feed shaft return spring assembly.



3. While holding the spring lock cover against the side of the headstock so the cover stays splined with the locking lug, as shown in **Figure 40**, loosen the jam nut and loosen the cover nut approximately $\frac{1}{4}$ " each.

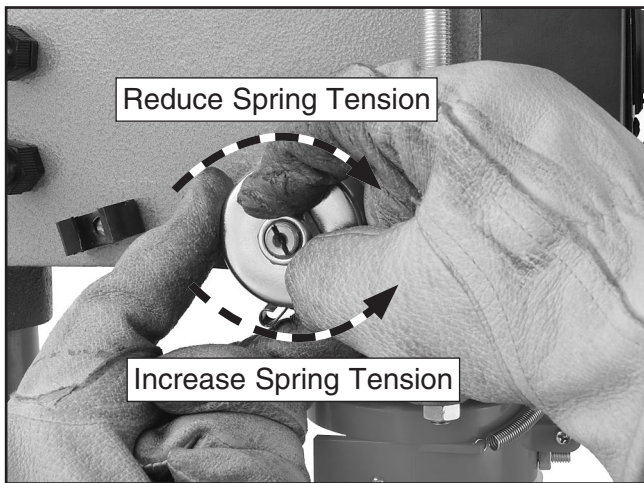

Figure 40. Loosening cover and jam nut.

⚠ CAUTION

A high-tension coiled spring is underneath the cover. Put on heavy leather gloves to protect yours hands from possible lacerations when removing the cover.

4. Put on heavy leather gloves to protect your hands from possible lacerations if the spring uncoils during the next step.
5. Pull the cover outward just enough to disengage the spring-cover lock slot from the locking lug.

CAUTION: *It is important to keep a good grip during this step. Letting go of the cover will cause the spring to rapidly uncoil.*

6. Rotate the cover counterclockwise to increase spring tension, or let the cover slowly unwind in the clockwise direction to reduce spring tension (see **Figure 40**).
7. Engage the next available spring-cover lock slot with the locking lug and hold the spring lock cover tightly against the side of the headstock.
8. Snug the cover nut against the spring cover just until the nut stops, and then back off the nut approximately $\frac{1}{3}$ turn, or just enough so there is no binding at complete spindle travel.
9. Hold the cover nut and tighten the jam nut against the cover nut.



SECTION 8: WIRING

These pages are current at the time of printing. However, in the spirit of improvement, we may make changes to the electrical systems of future machines. Compare the manufacture date of your machine to the one stated in this manual, and study this section carefully.

If there are differences between your machine and what is shown in this section, call Technical Support at (570) 546-9663 for assistance BEFORE making any changes to the wiring on your machine. An updated wiring diagram may be available. **Note:** *Please gather the serial number and manufacture date of your machine before calling. This information can be found on the main machine label.*

WARNING

Wiring Safety Instructions

SHOCK HAZARD. Working on wiring that is connected to a power source is extremely dangerous. Touching electrified parts will result in personal injury including but not limited to severe burns, electrocution, or death. Disconnect the power from the machine before servicing electrical components!

MODIFICATIONS. Modifying the wiring beyond what is shown in the diagram may lead to unpredictable results, including serious injury or fire. This includes the installation of unapproved after-market parts.

WIRE CONNECTIONS. All connections must be tight to prevent wires from loosening during machine operation. Double-check all wires disconnected or connected during any wiring task to ensure tight connections.

CIRCUIT REQUIREMENTS. You MUST follow the requirements at the beginning of this manual when connecting your machine to a power source.

WIRE/COMPONENT DAMAGE. Damaged wires or components increase the risk of serious personal injury, fire, or machine damage. If you notice that any wires or components are damaged while performing a wiring task, replace those wires or components.

MOTOR WIRING. The motor wiring shown in these diagrams is current at the time of printing but may not match your machine. If you find this to be the case, use the wiring diagram inside the motor junction box.















CAPACITORS/INVERTERS. Some capacitors and power inverters store an electrical charge for up to 10 minutes after being disconnected from the power source. To reduce the risk of being shocked, wait at least this long before working on capacitors.

EXPERIENCING DIFFICULTIES. If you are experiencing difficulties understanding the information included in this section, contact our Technical Support at (570) 546-9663.

NOTICE

The photos and diagrams included in this section are best viewed in color. You can view these pages in color at www.grizzly.com.

COLOR KEY

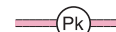
BLACK		BLUE		YELLOW		LIGHT BLUE	
WHITE		BROWN		YELLOW GREEN		BLUE WHITE	
GREEN		GRAY		PURPLE		TURQUOISE	
RED		ORANGE		PINK			



G7945/G7946 Wiring Diagram

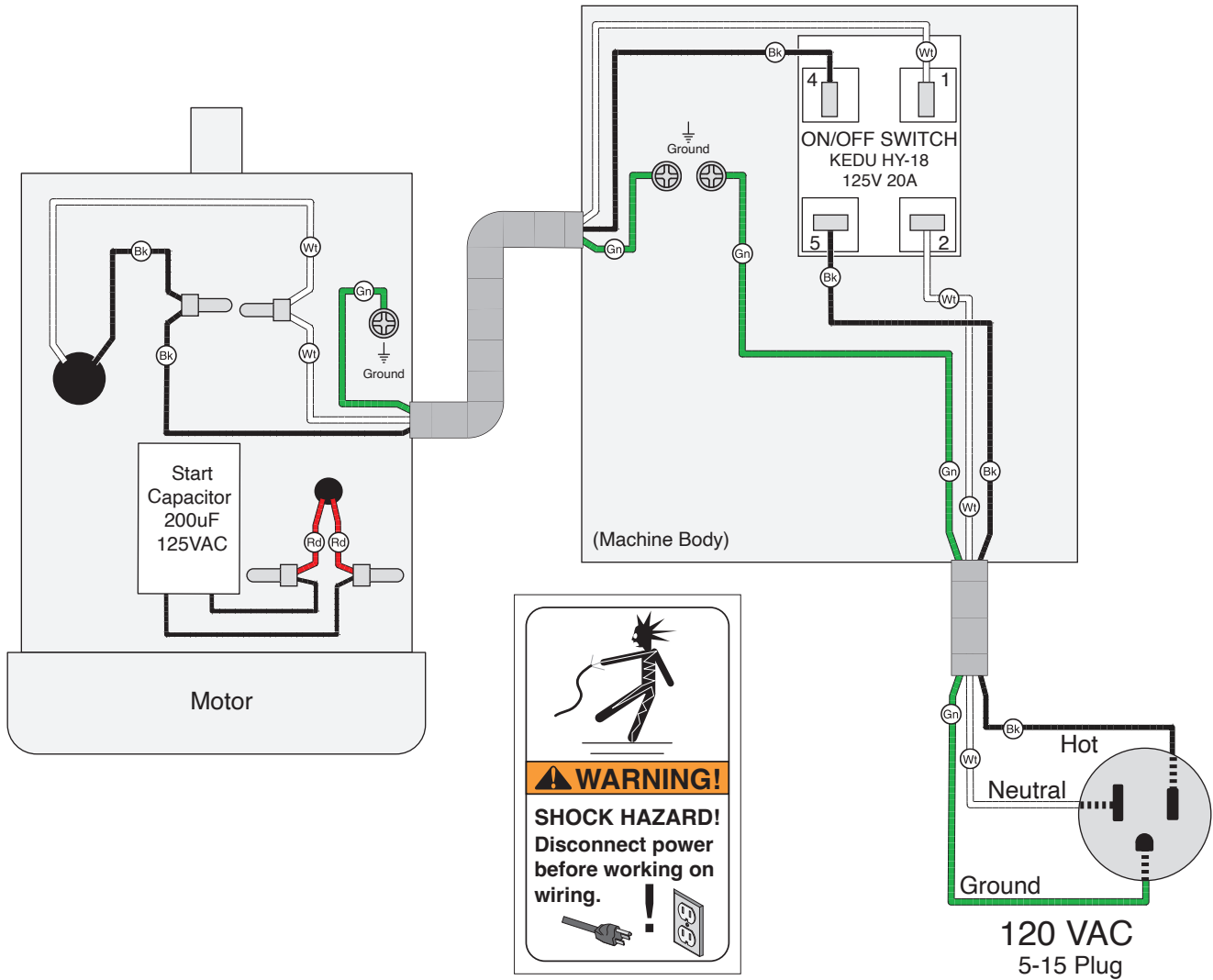

Electrical Components

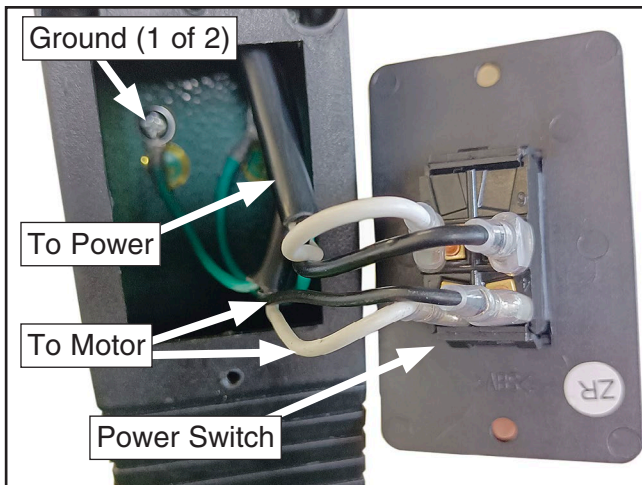

Figure 41. Power switch wiring.

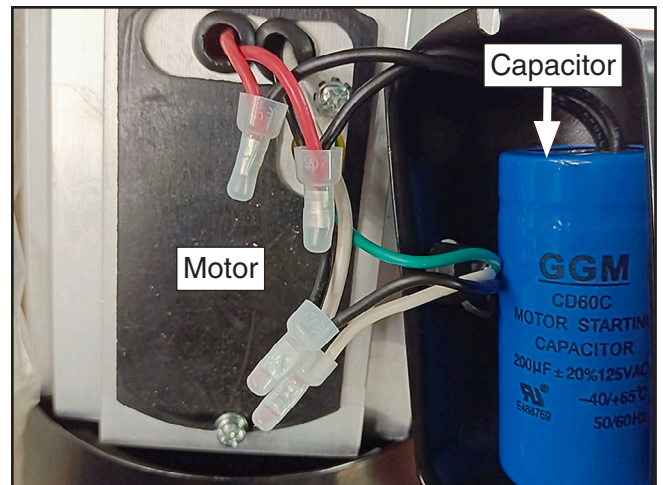
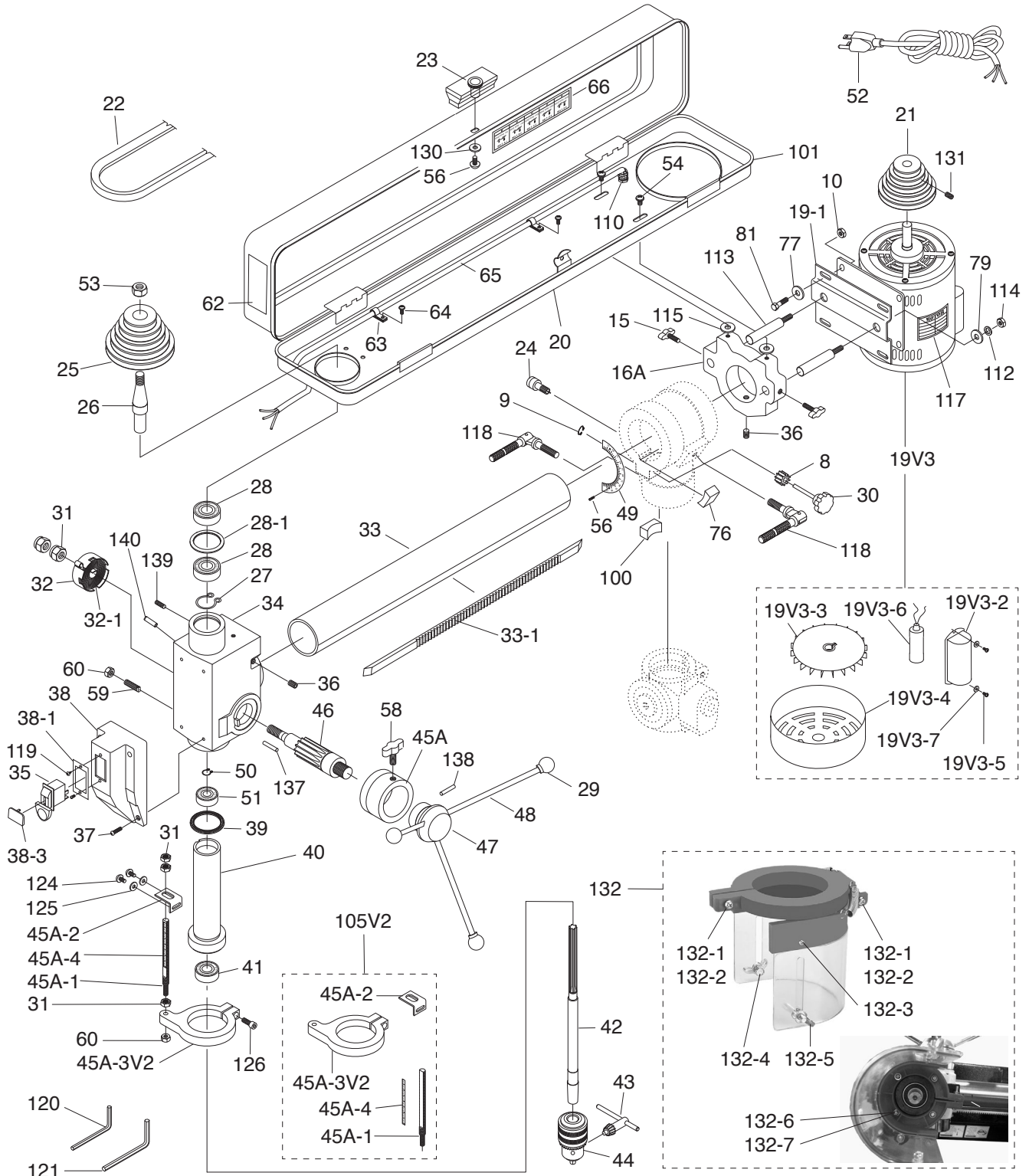

Figure 42. Motor wiring.



SECTION 9: PARTS

G7945/G7946 Main Parts



G7945/G7946 Main Parts List

REF	PART #	DESCRIPTION
8	P7945008	GEAR
9	P7945009	EXT RETAINING RING 9MM
10	P7945010	HEX NUT M8-1.25
15	P7945015	KNOB BOLT M8-1.25 X 22
16A	P7945016A	MOUNT PLATE V2.06.06
19V3	P7945019V3	MOTOR 1/2HP 120V 1-PH V3.10.23
19V3-1	P7945019V3-1	MOTOR MOUNT BRACKET V2.02.05
19V3-2	P7945019V3-2	CAPACITOR COVER
19V3-3	P7945019V3-3	MOTOR FAN
19V3-4	P7945019V3-4	FAN COVER
19V3-5	P7945019V3-5	PHLP HD SCR M4-.7 X 6
19V3-6	P7945019V3-6	S CAPACITOR 200M 125V 1-5/16 X 2-3/4
19V3-7	P7945019V3-7	FLAT WASHER 4MM
20	P7945020	PULLEY COVER
21	P7945021	MOTOR PULLEY
22	P7945022	V-BELT SPA1500 1500 X 13MM
23	P7945023	COVER KNOB M5-.8
24	P7945024	LOCK PIN
25	P7945025	SPINDLE PULLEY
26	P7945026	DRIVE SLEEVE
27	P7945027	EXT RETAINING RING 17MM
28	P7945028	BALL BEARING 6203ZZ
28-1	P7945028-1	SPACER
29	P7945029	KNOB M10-1.5 42D X 48L
30	P7945030	HORIZONTAL ADJ KNOB
31	P7945031	HEX NUT M12-1.5 THIN
32	P7945032	SPRING COVER
32-1	P7945032-1	COILED SPRING
33	P7945033	HORIZONTAL COLUMN
33-1	P7945033-1	HORIZONTAL COLUMN RACK
34	P7945034	HEADSTOCK
35	P7945035	ON/OFF SWITCH 110/220V
36	P7945036	SET SCREW M8-1.25 X 10
37	P7945037	PHLP HD SCR M5-.8 X 14
38	P7945038	SWITCH MOUNT COVER
38-1	P7945038-1	SWITCH PLATE
38-3	P7945038-3	PADDLE SWITCH KEY
39	P7945039	RUBBER WASHER
40	P7945040	QUILL SHAFT
41	P7945041	BALL BEARING 6202ZZ
42	P7945042	SPINDLE SHAFT JT#33
43	P7945043	CHUCK KEY
44	P7945044	CHUCK 1/16" - 5/8" JT#33
45A	P7945045A	COLLAR
45A-1	P7945045A-1	DEPTH STOP ROD
45A-2	P7945045A-2	DEPTH ROD BRACKET
45A-3V2	P7945045A-3V2	DEPTH STOP BRACKET V2.12.12
45A-4	P7945045A-4	DEPTH STOP SCALE
46	P7945046	PINION
47	P7945047	FEED COLLAR

REF	PART #	DESCRIPTION
48	P7945048	DOWNFEED HANDLE
49	P7945049	DEGREE SCALE
50	P7945050	EXT RETAINING RING 12MM
51	P7945051	BALL BEARING 6201
52	P7945052	POWER CORD 18G 3W 72" 5-15P
53	P7945053	PULLEY SET NUT
54	P7945054	PHLP HD SCR M6-1 X 10
56	P7945056	PHLP HD SCR M5-.8 X 8
58	P7945058	KNOB BOLT M8-1.25 X 22
59	P7945059	SET SCREW M8-1.25 X 25
60	P7945060	HEX NUT M8-1.25
62	P7945062	LOGO
63	P7945063	WIRE STRAP
64	P7945064	PHLP HD SCR M4-.7 X 8
65	P7945065	MOTOR SWITCH CORD
66	P7945066	SPEED CHART
76	P7945076	LOCKING GIB
77	P7945077	FLAT WASHER 8MM
79	P7945079	FLAT WASHER 10MM
81	P7945081	HEX BOLT M8-1.25 X 25
100	P7945100	LOCK SHOE
101	P7945101	RUBBER BUMPER
105V2	P7945105V2	DEPTH GAUGE KIT V2.12.12
110	P7945110	STRAIN RELIEF TYPE-1 M12-1.75
113	P7945113	GUIDE ROD 16 X 30MM
114	P7945114	HEX NUT M10-1.5
115	P7945115	RUBBER WASHER 7MM
117	P7945117	MOTOR LABEL
118	P7945118	LOCK LEVER M10-1.5 X 25
119	P7945119	TAP SCREW #8 X 3/8
120	P7945120	HEX WRENCH 3MM
121	P7945121	HEX WRENCH 4MM
124	P7945124	PHLP HD SCR M6-1 X 10
125	P7945125	FLAT WASHER 6MM
126	P7945126	CAP SCREW M8-1.25 X 20
130	P7945130	FLAT WASHER 5MM
131	P7945131	SET SCREW M6-1 X 10
132	P7945132	CHUCK GUARD ASSEMBLY
132-1	P7945132-1	PHLP HD SCR M4-.7 X 30
132-2	P7945132-2	HEX NUT M4-.7
132-3	P7945132-3	TAP SCREW M2.2 X 4.5
132-4	P7945132-4	HEX BOLT M5-.8 X 12
132-5	P7945132-5	WING NUT M5-.8
132-6	P7945132-6	PHLP HD SCR M4-.7 X 10
132-7	P7945132-7	FLAT WASHER 4MM
137	P7945137	ROLL PIN 6 X 20
138	P7945138	ROLL PIN 5 X 40
139	P7945139	SET SCREW M8-1.25 X 12
140	P7945140	ROLL PIN 5 X 20

We do our best to stock replacement parts when possible, but we cannot guarantee that all parts shown are available for purchase. Call **(800) 523-4777** or visit **www.grizzly.com/parts** to check for availability.



G7945 Column Parts

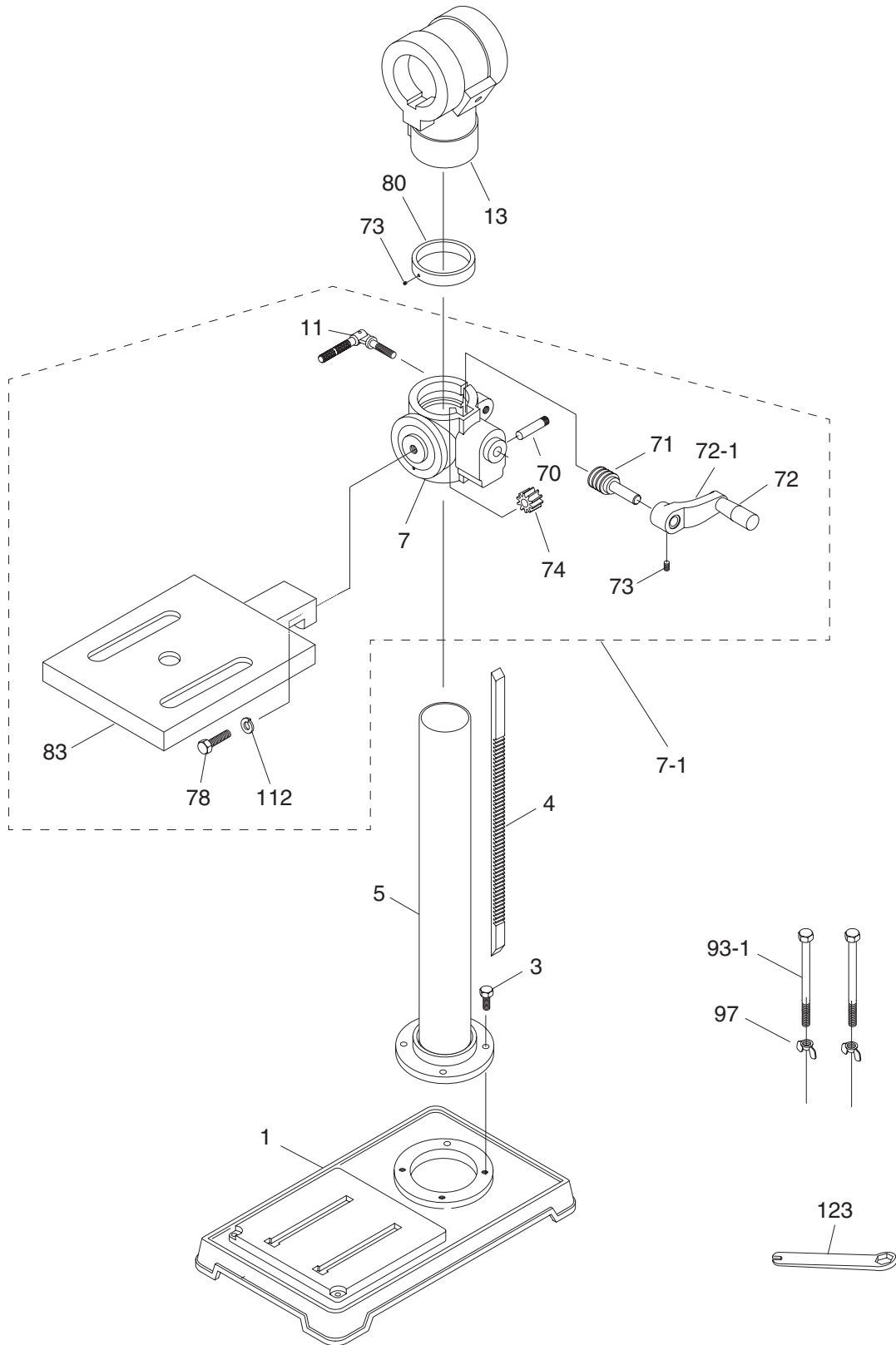

G7946 Column Parts

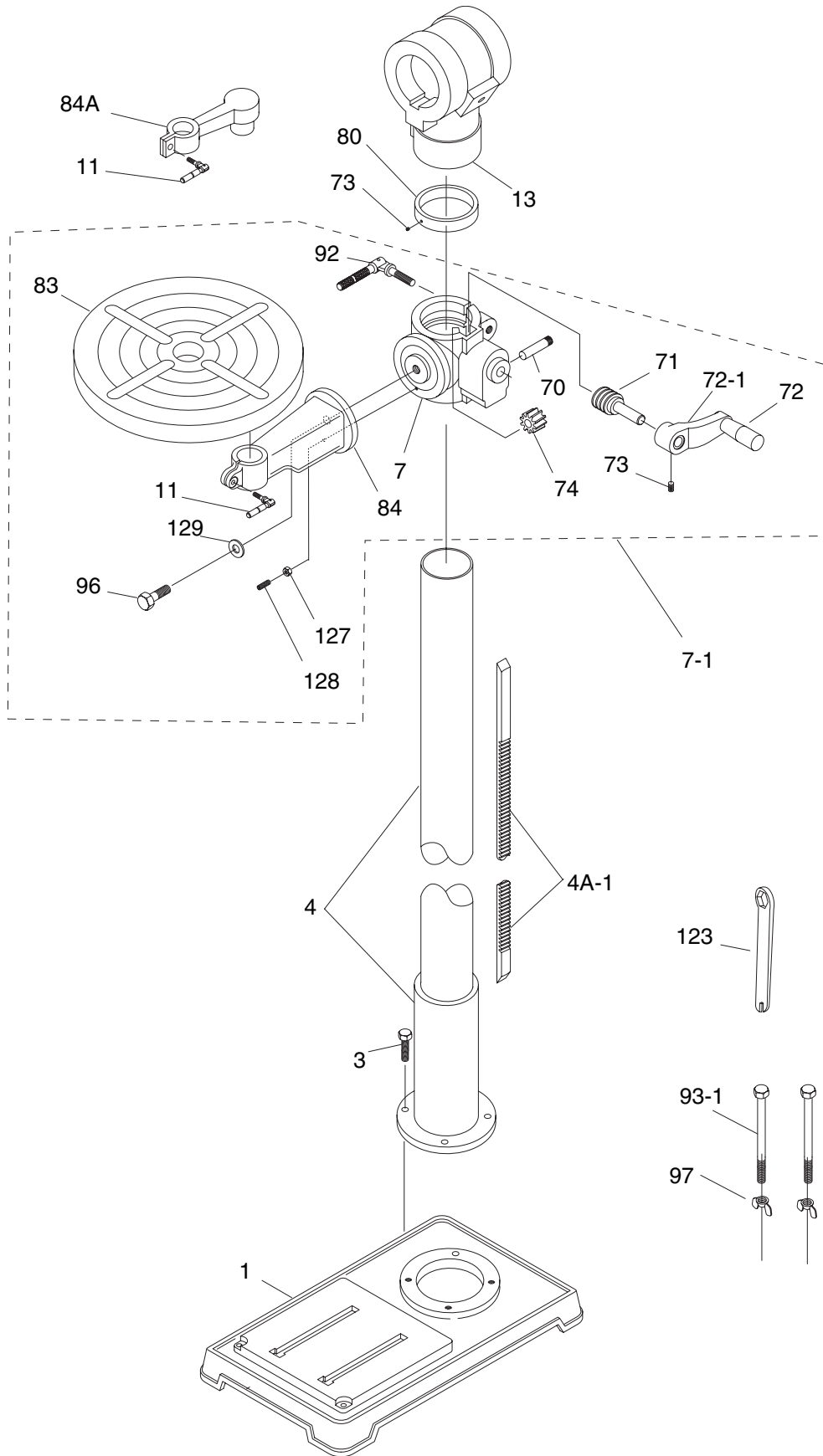

G7945 Column Parts List

REF	PART #	DESCRIPTION
1	P7945001	BASE
3	P7945003	HEX BOLT M8-1.25 X 20
4	P7945004	SHORT RACK
5	P7945005	SHORT VERTICAL COLUMN
7	P7945007	GEARED TABLE BRACKET
7-1	P7945007-1	TABLE BRACKET ASSEMBLY
11	P7945011	LOCK LEVER M10-1.5 X 30
13	P7945013	HORIZ BRACKET 2-5/16 V2.02.99
70	P7945070	PIN
71	P7945071	WORM SHAFT
72	P7945072	FIXED HANDLE M8-1.25 X 10, 21 X 76

REF	PART #	DESCRIPTION
72-1	P7945072-1	CRANK HANDLE
73	P7945073	SET SCREW M6-1 X 10
74	P7945074	10T GEAR
78	P7945078	HEX BOLT M12-1.75 x 30
80	P7945080	COLUMN RING
83	P7945083	SQUARE TABLE
93-1	P7945093-1	HEX BOLT M8-1.25 X 125
97	P7945097	WING NUT M8-1.25
112	P7945112	LOCK WASHER 12MM
123	P7945123	SPECIAL WRENCH

G7946 Column Parts List

REF	PART #	DESCRIPTION
1	P7946001	BASE V2.04.03
3	P7946003	HEX BOLT M10-1.5 X 35
4	P7946004	LONG COLUMN W/COLUMN HOLDER V3.02.99
4A-1	P7946004A-1	LONG RACK
7	P7946007	GEARED TABLE BRACKET V2.03.99
7-1	P7946007-1	COMPLETE TBL BRKT ASSY
11	P7946011	LOCK LEVER M10-1.5 X 50
13	P7946013	HORIZONTAL COLUMN BRACKET
70	P7946070	AXLE
71	P7946071	WORM PINION
72	P7946072	FIXED HANDLE M8-1.25 X 10, 21 X 76
72-1	P7946072-1	CRANK HANDLE
73	P7946073	SET SCREW M6-1 X 10

REF	PART #	DESCRIPTION
74	P7946074	WORM GEAR
80	P7946080	COLUMN RING
83	P7946083	ROUND TABLE
84	P7946084	COLUMN SUPPORT ARM
84A	P7946084A	TABLE SUPPORT ARM
92	P7946092	LOCK LEVER M12-1.75 X 50
93-1	P7946093-1	HEX BOLT M8-1.25 X 125
96	P7946096	HEX BOLT 5/8-13 X 1-1/2
97	P7946097	WING NUT M8-1.25
123	P7946123	SPECIAL WRENCH
127	P7946127	HEX NUT M6-1
128	P7946128	LOCATING PIN
129	P7946129	FLAT WASHER 16MM



G7945/G7946 Labels & Cosmetics



102V3

 <p>MODEL G7945 BENCHTOP RADIAL DRILL PRESS Manufactured for Grizzly in China</p>	<p>Specifications</p> <p>Motor: 1/2 HP, 120V, 7A, 60 Hz Swing: 11"-34" Spindle Speeds: 550-3000 RPM Max. Spindle to Table Dist.: 12-3/4" Max. Spindle to Base Dist.: 17-1/2" Spindle Travel: 3-1/4" Spindle Taper: JT#33 Weight: 88 lbs.</p>	<p>▲WARNING!</p> <p>To reduce the risk of serious injury when using this machine:</p> <ol style="list-style-type: none"> 1. Read and understand owner's manual before operating. 2. Always wear approved safety glasses. 3. Only plug power cord into a grounded outlet. 4. Disconnect power before setting up or servicing. 5. Tie back long hair, roll up long sleeves, and DO NOT wear loose clothing, gloves, or jewelry. 6. Keep all guards and covers in place during operation. 7. Clamp workpiece to table to prevent rotation. 8. Avoid putting hands where they could slip into rotating bits. 9. Always remove chuck keys and other tools before starting. 10. Use correct speeds for drilling accessories and workpiece. 11. Do not expose to rain or use in wet locations. 12. Prevent unauthorized use by children or untrained users.
	<p>QR Code</p> <p>Date: _____</p> <p>Serial # _____</p>	

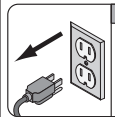
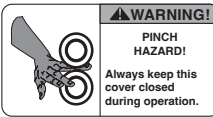
133

 <p>▲WARNING! INJURY/SHOCK HAZARD! Disconnect power before adjustments, maintenance, or service.</p>	 <p>▲WARNING! PINCH HAZARD! Always keep this cover closed during operation.</p>
---	--

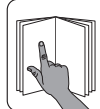
134

 <p>▲WARNING! To reduce risk of death or serious injury, read manual BEFORE using machine. To get a new manual, call (800) 523-4777 or go to www.grizzly.com.</p>	 <p>▲WARNING! ENTANGLEMENT HAZARD! Tie back long hair, roll up long sleeves, and remove loose clothing, jewelry, or gloves to prevent getting caught in moving parts.</p>	 <p>▲WARNING! EYE/FACE INJURY HAZARD! Always wear ANSI-approved safety glasses and face shield when using this machine.</p>
--	--	--

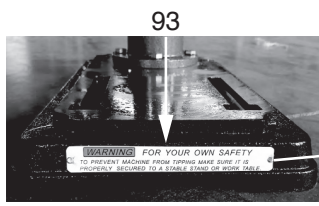

116

REF	PART #	DESCRIPTION
93	P7945093	LABEL (TIPPING WARNING)
102V3	P7945102V3	MACHINE ID LABEL V3.10.23 (G7945)
102V3	P7946102V3	MACHINE ID LABEL V3.10.23 (G7946)
116	P7945116	ELECTRICITY WARNING LABEL

REF	PART #	DESCRIPTION
133	P7945133	SHOCK-PINCH WARNING LABEL
134	P7945134	READ-ENTANGLE-EYE LABEL
135	P7945135	TOUCH-UP PAINT, GRIZZLY GREEN
136	P7945136	TOUCH-UP PAINT, GLOSSY BLACK

▲WARNING

Safety labels help reduce the risk of serious injury caused by machine hazards. If any label comes off or becomes unreadable, the owner of this machine **MUST** replace it in the original location before resuming operations. For replacements, contact (800) 523-4777 or www.grizzly.com.



WARRANTY & RETURNS

Grizzly Industrial, Inc. warrants every product it sells for a period of **1 year** to the original purchaser from the date of purchase. This warranty does not apply to defects due directly or indirectly to misuse, abuse, negligence, accidents, repairs or alterations or lack of maintenance. This is Grizzly's sole written warranty and any and all warranties that may be implied by law, including any merchantability or fitness, for any particular purpose, are hereby limited to the duration of this written warranty. We do not warrant or represent that the merchandise complies with the provisions of any law or acts unless the manufacturer so warrants. In no event shall Grizzly's liability under this warranty exceed the purchase price paid for the product and any legal actions brought against Grizzly shall be tried in the State of Washington, County of Whatcom.

We shall in no event be liable for death, injuries to persons or property or for incidental, contingent, special, or consequential damages arising from the use of our products.

The manufacturers reserve the right to change specifications at any time because they constantly strive to achieve better quality equipment. We make every effort to ensure that our products meet high quality and durability standards and we hope you never need to use this warranty.

In the event you need to use this warranty, contact us by mail or phone and give us all the details. We will then issue you a "Return Number," which must be clearly posted on the outside as well as the inside of the carton. We will not accept any item back without this number. Proof of purchase must accompany the merchandise.

Please feel free to write or call us if you have any questions about the machine or the manual.

Thank you again for your business and continued support. We hope to serve you again soon.

To take advantage of this warranty, you must register it at <https://www.grizzly.com/forms/warranty>, or you can scan the QR code below to be automatically directed to our warranty registration page. Enter all applicable information for the product.



grizzly.com[®]
TOOL WEBSITE

Buy Direct and Save with Grizzly[®] – Trusted, Proven and a Great Value!
~Since 1983~

*Visit Our Website Today For
Current Specials!*

**ORDER
24 HOURS A DAY!
1-800-523-4777**

