

Grizzly **Industrial, Inc.**®

13½" x 40" Gear Head Lathe

MODEL G4016

Instruction Manual

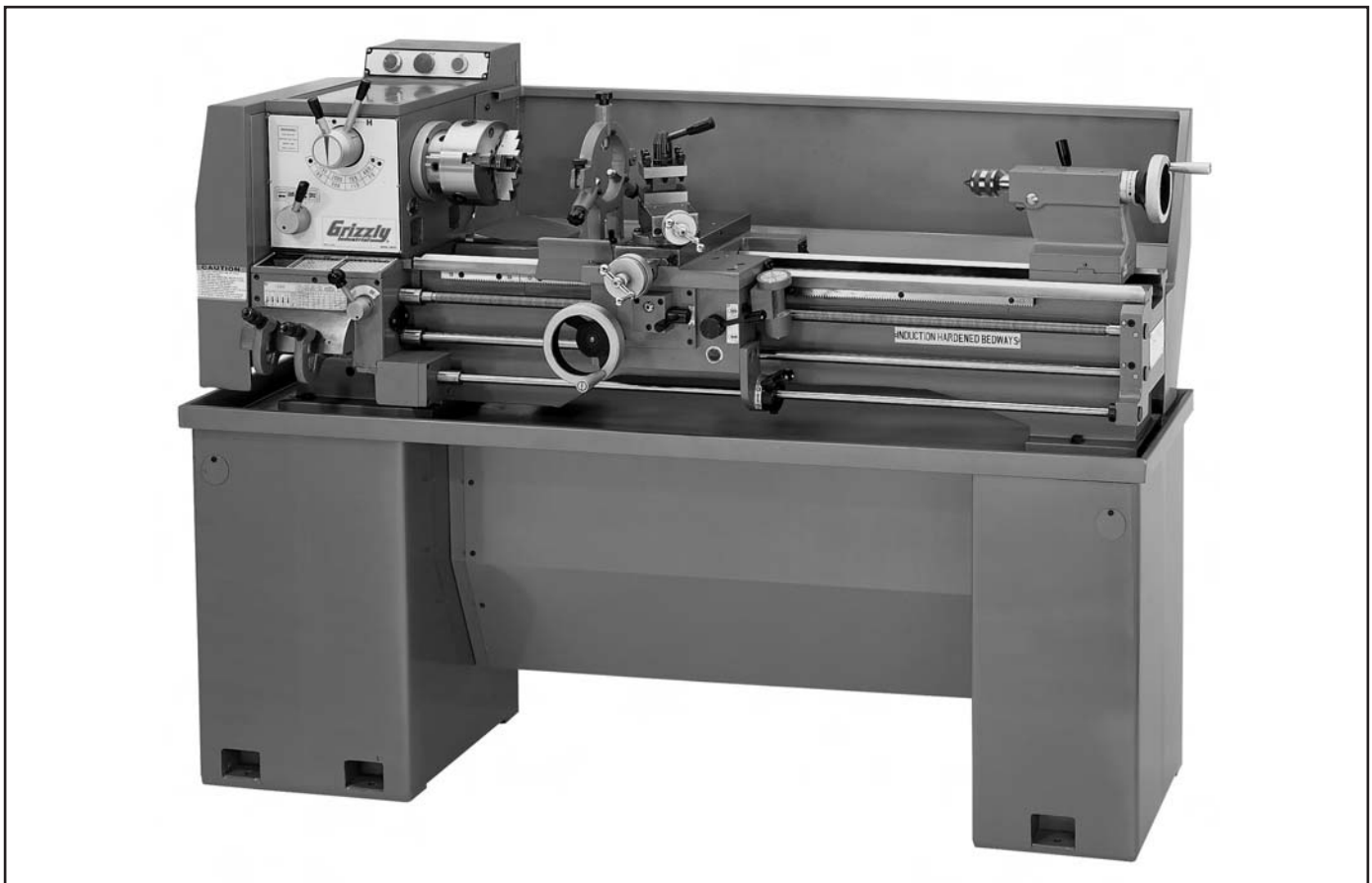

COPYRIGHT © AUGUST, 2005 BY GRIZZLY INDUSTRIAL, INC.

**WARNING: NO PORTION OF THIS MANUAL MAY BE REPRODUCED IN ANY SHAPE
OR FORM WITHOUT THE WRITTEN APPROVAL OF GRIZZLY INDUSTRIAL, INC.**

#EW7152 PRINTED IN CHINA



WARNING!

Some dust created by power sanding, sawing, grinding, drilling, and other construction activities contains chemicals known to the State of California to cause cancer, birth defects or other reproductive harm. Some examples of these chemical are:

- **Lead from lead-based paints.**
- **Crystalline silica from bricks, cement and other masonry products.**
- **Arsenic and chromium from chemically-treated lumber.**

Your risk from these exposures varies, depending on how often you do this type of work. To reduce your exposure to these chemicals: Work in a well ventilated area, and work with approved safety equipment, such as those dust masks that are specially designed to filter out microscopic particles.

WARNING

Safety labels warn about machine hazards and ways to prevent injury. The owner of this machine MUST maintain the original location and readability of the labels on the machine. If any label is removed or becomes unreadable, REPLACE that label before using the machine again. Contact Grizzly at (800) 523-4777 or www.grizzly.com to order new labels.

Table of Contents

INTRODUCTION	3
Foreword	3
Contact Info.....	3
Machine Data Sheet.....	4
Identification	7
SECTION 1: SAFETY	8
Safety Instructions for Machinery.....	8
Additional Safety Instructions for Lathes.....	10
Glossary Of Terms	11
SECTION 2: CIRCUIT REQUIREMENTS	12
220V Single-Phase	12
SECTION 3: SET UP	13
Set Up Safety	13
Items Needed for Set Up	13
Unpacking	13
Inventory.....	14
Hardware Recognition Chart.....	15
Clean Up	16
Site Considerations	16
Lathe Assembly and Placement	17
Mounting to Shop Floor.....	18
Power Cord	19
Check Gear Oil.....	19
Test Run.....	20
Spindle Break-in Procedures	21
SECTION 4: OPERATIONS	22
Operation Safety	22
Three-Jaw Scroll Chuck	22
Reversing Jaws	25
Four-Jaw Independent Chuck	26
Faceplate.....	27
Tailstock	28
Centers.....	29
Cutting Shallow Tapers with Tailstock	30
Tailstock Alignment	30
Steady Rest.....	32
Follow Rest	32
Setting Compound Slide	33
Four-Way Tool Post	33
Gap Removal	34
Setting RPM	34
Manual Feed	35
Power Feed.....	36
Setting Feed Rate	37
Thread Settings.....	38
Changing Gears for Metric Threads.....	39
Threading Operation	40
SECTION 5: ACCESSORIES	41

SECTION 6: MAINTENANCE	46
Schedule	46
Cleaning	46
Unpainted Cast Iron	46
Lubrication	46
SECTION 7: SERVICE	48
About Service	48
Troubleshooting.....	48
Cross Feed Backlash	51
Gibs	52
Replacing and Tightening V-Belt	53
Electrical Components	54
Headstock Gears 1	55
Headstock Gears 2	56
Headstock Case.....	57
Lathe Bed.....	60
Gearbox Case	62
Gearbox Components	63
Change Gear Assembly	64
Gear Lever Assembly.....	65
Apron Case	67
Apron Gears.....	68
Thread Dial.....	69
Carriage Assembly	71
Cross Slide Assembly	72
Tailstock Assembly	74
Tailstock Lock Assembly.....	75
Follow and Steady Rest Assemblies.....	76
Electrical Components and Accessories.....	77
Stand Components	79
Safety Labels	80
WARRANTY AND RETURNS	82

INTRODUCTION

Foreword

We are proud to offer the Model G4016 13½" x 40" Gear Head Lathe. This machine is part of a growing Grizzly family of fine metalworking machinery. When used according to the guidelines set forth in this manual, you can expect years of trouble-free, enjoyable operation and proof of Grizzly's commitment to customer satisfaction.

We are pleased to provide this manual with the Model G4016. It was written to guide you through assembly, review safety considerations, and cover general operating procedures. It represents our effort to produce the best documentation possible.

The specifications, drawings, and photographs illustrated in this manual represent the Model G4016 as supplied when the manual was prepared. However, owing to Grizzly's policy of continuous improvement, changes may be made at any time with no obligation on the part of Grizzly. For your convenience, we always keep current Grizzly manuals available on our website at **www.grizzly.com**. Any updates to your machine will be reflected in these manuals as soon as they are complete. Visit our site often to check for the latest updates to this manual!

Contact Info

If you have any comments regarding this manual, please write to us at the address below:

Grizzly Industrial, Inc.
C/O Technical Documentation Manager
P.O. Box 2069
Bellingham, WA 98227-2069

We stand behind our machines. If you have any service questions or parts requests, please call or write us at the location listed below.

Grizzly Industrial, Inc.
1203 Lycoming Mall Circle
Muncy, PA 17756
Phone: (570) 546-9663
Fax: (800) 438-5901
E-Mail: techsupport@grizzly.com
Web Site: <http://www.grizzly.com>





MACHINE DATA SHEET

Customer Service #: (570) 546-9663 · To Order Call: (800) 523-4777 · Fax #: (800) 438-5901

MODEL G4016 13-1/2" X 40" GEAR HEAD LATHE W/ STAND

Product Dimensions:

Weight 1261 lbs.
 Length/Width/Height 71-1/2 x 26 x 52-1/2 in.
 Foot Print (Length/Width) 71 x 22 in.

Shipping Dimensions:

Carton #1

Type Wood Crate
 Content Machine
 Weight 1155 lbs.
 Length/Width/Height 76 x 30 x 29 in.

Carton #2

Type Cardboard
 Content Left Stand
 Weight 99 lbs.
 Length/Width/Height 28 x 19 x 18 in.

Carton #3

Type Cardboard
 Content Right Stand
 Weight 76 lbs.
 Length/Width/Height 28 x 17 x 14 in.

Electrical:

Switch Magnetic Switch
 Switch Voltage 220
 Recommended Breaker Size 15 amp
 Plug No

Motors:

Main

Type TEFC Capacitor Start Induction
 Horsepower 2
 Voltage 220
 Prewired 220
 Phase Single
 Amps 11.9
 RPM 1725
 Cycle 60
 Number Of Speeds 1
 Power Transfer Belt Drive to Gear
 Bearings Shielded and Permanently Lubricated

Information contained herein is deemed accurate as of 8/20/2005 and represents our most recent product specifications.



Main Specifications:

Operation Info

Swing Over Bed	13-1/2 in.
Dist Between Centers	40 in.
Swing Over Cross Slide	8 in.
Swing Over Saddle	8 in.
Swing Over Gap	19 in.
Max Tool Bit Size	1/2 in.
Compound Travel	2-7/8 in.
Carriage Travel	35 in.
Cross Slide Travel	6-1/4 in.

Headstock Info

Spindle Bore	1-7/16 in.
Spindle Taper	MT#5
No Of Spindle Speeds	8
Range Of Spindle Speeds	78, 128, 210, 330, 510, 830, 1360, 2100 RPM
Spindle Type	D1-4 Camlock
Spindle Bearings	Tapered Roller

Tailstock Info

Tailstock Travel	3-1/2 in.
Tailstock Taper	MT#3
Tailstock Barrel Dia	1-1/4 in.

Threading Info

No Of Inch Threads	40
Range Of Inch Threads	4 - 112 TPI
Range Of Longitudinal Feeds0036 - .1005 in.
No Of Longitudinal Feeds	40
No Of Cross Feeds	40
Range Of Cross Feeds0012 - .0345 in./rev.
No Of Metric Threads	40
Range Of Metric Threads	0.2 - 6 mm

Dimensions

Bed Width	7-3/8 in.
Leadscrew TPI	8
Leadscrew Length	51 in.
Steady Rest Capacity	2-3/4 in.
Follow Rest Capacity	2 in.
Faceplate Size	12 in.
Leadscrew Diameter	7/8 in.
Feed Rod Dia	3/4 in.
Floor To Center Height	45-1/2 in.

Construction

Base Construction	Cast Iron
Headstock Construction	Cast Iron
Headstock Gears Construction	Flame Hardened Steel
Bed Construction	Induction Hardened Cast Iron
Body Construction	Cast Iron
Stand Construction	Cast Iron
Paint	Epoxy

Other

Kilowatt Output	1.5
-----------------------	-----



Other Specifications:

Country Of Origin China
Warranty 1 Year
Serial Number Location Tailstock End Between Bed Ways

Features:

Cast Iron Construction Throughout
Chip Pan
Flame Hardened Headstock Gears
Full Length Splash Guard
Heavy Duty Stand
Induction Hardened Bedways
Jog Button and Emergency Stop
Tapered Roller and Ball Bearings
Threading Dial

Accessories Included:

12" Face Plate
2 MT#3 Dead Centers
4 Way Turret Tool Post
6" 3-Jaw Chuck with 2 Piece Jaws
8" 4-Jaw Chuck
Center Sleeve
Drill Chuck with Arbor
Follow Rest
Live Center
Oil Can
Set Up Tools
Steady Rest
Tool Box



Identification

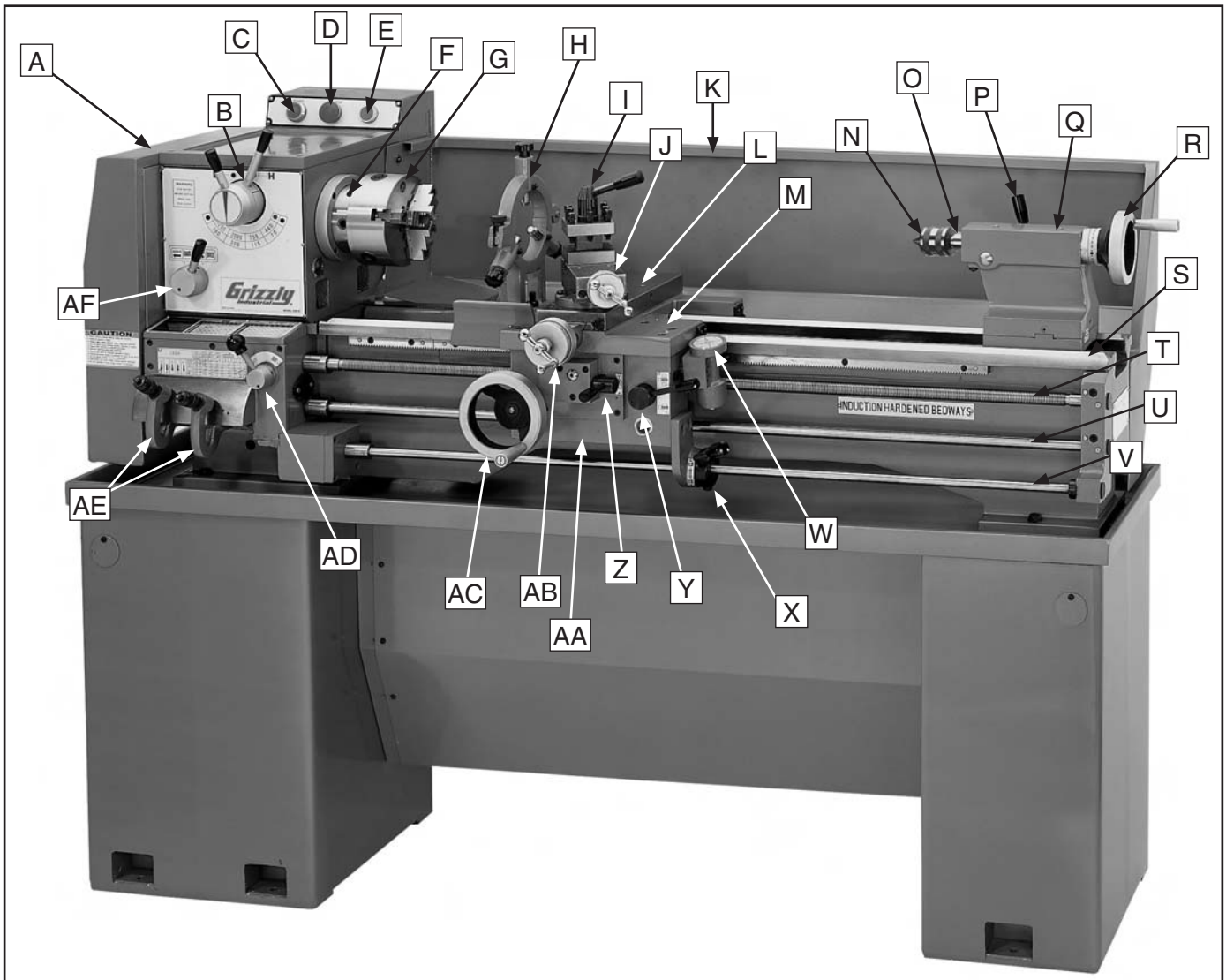

- | | |
|--|---|
| A. Headstock | Q. Tailstock |
| B. Spindle Speed Selection Levers | R. Tailstock Handwheel |
| C. Power Indicator Light | S. Bed Ways |
| D. Emergency Stop Switch | T. Lead Screw |
| E. Jog Button | U. Feed Rod |
| F. Spindle | V. Spindle Forward/Reverse Rod |
| G. Three-Jaw Chuck | W. Thread Dial |
| H. Steady Rest | X. Spindle Forward/Reverse Lever |
| I. Four-Way Tool Post | Y. Half-Nut Lever |
| J. Compound Slide | Z. Feed Selector Lever |
| K. Backsplash | AA. Carriage Apron |
| L. Cross Slide | AB. Cross Feed Handwheel |
| M. Carriage | AC. Longitudinal Feed Handwheel |
| N. Live Center | AD. Feed/Lead Selector Knob |
| O. Quill | AE. Feed Speed Selection Levers |
| P. Quill Lock | AF. Feed Direction Selector |



SECTION 1: SAFETY

WARNING

For Your Own Safety, Read Instruction Manual Before Operating this Machine

The purpose of safety symbols is to attract your attention to possible hazardous conditions. This manual uses a series of symbols and signal words which are intended to convey the level of importance of the safety messages. The progression of symbols is described below. Remember that safety messages by themselves do not eliminate danger and are not a substitute for proper accident prevention measures.



Indicates an imminently hazardous situation which, if not avoided, **WILL** result in death or serious injury.



Indicates a potentially hazardous situation which, if not avoided, **COULD** result in death or serious injury.



Indicates a potentially hazardous situation which, if not avoided, **MAY** result in minor or moderate injury. It may also be used to alert against unsafe practices.

NOTICE

This symbol is used to alert the user to useful information about proper operation of the machine.

WARNING

Safety Instructions for Machinery

- 1. READ THROUGH THE ENTIRE MANUAL BEFORE STARTING MACHINERY.** Machinery presents serious injury hazards to untrained users.
- 2. ALWAYS USE ANSI APPROVED SAFETY GLASSES WHEN OPERATING MACHINERY.** Everyday eyeglasses only have impact resistant lenses, they are NOT safety glasses.
- 3. ALWAYS WEAR AN ANSI APPROVED RESPIRATOR WHEN OPERATING MACHINERY THAT PRODUCES DUST.** Wood dust is a carcinogen and can cause cancer and severe respiratory illnesses.
- 4. ALWAYS USE HEARING PROTECTION WHEN OPERATING MACHINERY.** Machinery noise can cause permanent hearing damage.
- 5. WEAR PROPER APPAREL. DO NOT** wear loose clothing, gloves, neckties, rings, or jewelry which may get caught in moving parts. Wear protective hair covering to contain long hair and wear non-slip footwear.
- 6. NEVER OPERATE MACHINERY WHEN TIRED, OR UNDER THE INFLUENCE OF DRUGS OR ALCOHOL.** Be mentally alert at all times when running machinery.



WARNING

Safety Instructions for Machinery

7. **ONLY ALLOW PROPERLY TRAINED AND SUPERVISED PERSONNEL OPERATE MACHINERY.** Make sure operation instructions are safe and clearly understood.
8. **KEEP CHILDREN AND VISITORS AWAY.** Keep all children and visitors a safe distance from the work area.
9. **MAKE WORKSHOP CHILD PROOF.** Use padlocks, master switches, and remove start switch keys.
10. **NEVER LEAVE WHEN MACHINE IS RUNNING.** Turn power **OFF** and allow all moving parts to come to a complete stop before leaving machine unattended.
11. **DO NOT USE IN DANGEROUS ENVIRONMENTS.** DO NOT use machinery in damp, wet locations, or where any flammable or noxious fumes may exist.
12. **KEEP WORK AREA CLEAN AND WELL LIT.** Clutter and dark shadows may cause accidents.
13. **USE A GROUNDED EXTENSION CORD RATED FOR THE MACHINE AMPERAGE.** Undersized cords overheat and lose power. Replace extension cords if they become damaged. DO NOT use extension cords for 220V machinery.
14. **ALWAYS DISCONNECT FROM POWER SOURCE BEFORE SERVICING MACHINERY.** Make sure switch is in OFF position before reconnecting.
15. **MAINTAIN MACHINERY WITH CARE.** Keep blades sharp and clean for best and safest performance. Follow instructions for lubricating and changing accessories.
16. **MAKE SURE GUARDS ARE IN PLACE AND WORK CORRECTLY BEFORE USING MACHINERY.**
17. **REMOVE ADJUSTING KEYS AND WRENCHES.** Make a habit of checking for keys and adjusting wrenches before turning machinery **ON**.
18. **CHECK FOR DAMAGED PARTS BEFORE USING MACHINERY.** Check for binding and alignment of parts, broken parts, part mounting, loose bolts, and any other conditions that may affect machine operation. Repair or replace damaged parts.
19. **USE RECOMMENDED ACCESSORIES.** Refer to the instruction manual for recommended accessories. The use of improper accessories may cause risk of injury.
20. **DO NOT FORCE MACHINERY.** Work at the speed for which the machine or accessory was designed.
21. **SECURE WORKPIECE.** Use clamps or a vise to hold the workpiece when practical. A secured workpiece protects your hands and frees both hands to operate the machine.
22. **DO NOT OVERREACH.** Keep proper footing and balance at all times.
23. **MANY MACHINES WILL EJECT THE WORKPIECE TOWARD OPERATOR.** Know and avoid conditions that cause the workpiece to "kickback."
24. **ALWAYS LOCK MOBILE BASES (IF USED) BEFORE OPERATING MACHINERY.**
25. **ALLERGIC REACTIONS.** Certain metal shavings and cutting fluids may cause an allergic reaction in people and animals, especially when cutting fumes can be inhaled. Make sure you know what type of metal and cutting fluid you will be exposed to and how to avoid contamination.



WARNING

Additional Safety Instructions for Lathes

- 1. TOOL SELECTION.** Always use the proper cutting tool for the material you are turning. Make sure it is sharp and held firmly in the tool post. Adjust tool post to provide proper support for the tool you will be using.
- 2. MOUNTING WORKPIECE.** Make sure workpiece is properly mounted before starting lathe. A workpiece thrown from the chuck may severely injure you or a bystander.
- 3. CHUCK KEY SAFETY.** Never let go of the chuck key while it is still in the chuck to prevent leaving the chuck key in the chuck.
- 4. WORKPIECE CLEARANCE.** Check workpiece clearance with tool post, compound slide, cross slide, and carriage by rotating chuck by hand before turning lathe **ON**.
- 5. CHANGING SPEEDS AND REVERSING.** Turn lathe **OFF** and allow the spindle to completely stop before changing speeds or reversing the spindle. **DO NOT** slow or stop the lathe chuck by using your hand.
- 6. SPEED SELECTION.** Select an appropriate speed for the type of work, material, and tool bit. Allow the lathe to reach full speed before beginning a cut.
- 7. CLEARING CHIPS.** Always use a brush to clear chips. Never clear chips when the spindle is rotating.
- 8. LEAVING LATHE.** Always shut the lathe **OFF** before you leave it unattended. An unsupervised lathe that is running invites accidents.
- 9. LATHE WORKING CONDITION.** Maintain your lathe in proper working condition. Never operate with damaged or worn parts. Perform routine inspections and maintenance promptly when scheduled.
- 10. MAINTENANCE PROCEDURES.** Make sure lathe is turned **OFF**, disconnected from power, and all moving parts have come to a complete stop before starting any inspection, adjustment, or maintenance.
- 11. AUTOMATIC FEEDS.** Release automatic feeds after completing a job. Automatic feeds left engaged can cause a "crash" after turning the lathe **ON**.
- 12. AVOIDING ENTANGLEMENT.** Tie up long hair or ponytails, and remove loose clothing, belts, or jewelry items to avoid entanglement with moving parts.
- 13. CHANGING CHUCKS.** Large lathe chucks are heavy and awkward to hold. Get assistance when installing large chucks. Always place a board or piece of plywood across the bedway when removing or installing chucks to avoid the possibility of a finger pinch occurring between a loose chuck and the edges of the bedway.

WARNING

Like all machines there is danger associated with the Model G4016. Accidents are frequently caused by lack of familiarity or failure to pay attention. Use this machine with respect and caution to lessen the possibility of operator injury. If normal safety precautions are overlooked or ignored, serious personal injury may occur.

CAUTION

No list of safety guidelines can be complete. Every shop environment is different. Always consider safety first, as it applies to your individual working conditions. Use this and other machinery with caution and respect. Failure to do so could result in serious personal injury, damage to equipment, or poor work results.



Glossary Of Terms

The following is a list of common definitions, terms and phrases used throughout this manual as they relate to this lathe and metalworking in general. Become familiar with these terms for assembling, adjusting or operating this machine. Your safety is VERY important to us at Grizzly!

Arbor: A machine shaft that supports a cutting tool.

Backlash: Wear in a screw or gear mechanism that may result in slippage, vibration and loss of tolerance.

Collet: A conical shaped split-sleeve bushing that holds round or rectangular tool and/or workpieces by their outside diameter.

Cross Feed: Lathe—Movement of cutting tool across the end of the workpiece.
Mill—The movement of the table toward or away from the column.

Cross Slide: A fixture attached to the lathe carriage that holds the compound rest and can be moved in and out.

Cutting Speed: The distance a point on a cutter moves in one minute, expressed in meters or feet per minute.

Dial Indicator: An instrument used in setup and inspection work that shows on a dial the amount of error in size or alignment of a part.

Dividing Head: A milling machine accessory used to divide a circular object into a number of equal parts.

Down Milling or Climb Milling: Feeding the workpiece in the same direction as the cutter rotation (opposite of standard milling).

End Mill: A cutter with cutting surfaces on both the circumference and end.

Facing: In lathe work, cutting across the end of a workpiece, usually to machine a flat surface.

Feed: The movement of a cutting tool into a workpiece.

Fixture: A device that securely holds the workpiece in place during cutting operation as opposed to a **Jig** which is used to hold and guide a workpiece through an operation.

Gib: A tapered wedge located along a sliding member to take up wear or to ensure a proper fit.

Headstock: The major lathe component that houses the spindle and motor drive system to turn the workpiece.

Lathe Center: A lathe accessory with a 60° point which is inserted into the headstock or tailstock of the lathe and is used to support the workpiece.

Leadscrew: Lathe—The long screw that is driven by the end gears and supplies power to the carriage. Mill—The screws that move the table in longitudinal, transverse, or vertical directions.

Spindle: The revolving shaft that holds and drives the workpiece or cutting tool.

Tailstock: A moveable fixture opposite of the headstock on a lathe that has a spindle used to support one end of a workpiece and for holding tools.

Toolpost: The part of the compound rest that holds the tool holder.

Turret: Lathe—A machine fixture that holds multiple tools and can be revolved and indexed to position. Mill—The part of a mill that rotates on the column and can be set to a specific degree.

Ways: The precision machined and flat tracks on a lathe or mill on which the carriage, tailstock and the mills table and knee slide.



SECTION 2: CIRCUIT REQUIREMENTS

220V Single-Phase

!WARNING

Serious personal injury could occur if you connect the machine to the power source before you have completed the set up process. DO NOT connect the machine to the power source until instructed to do so.

Amperage Draw

The 2 HP motor on the Model G4016 will draw the following amps:

Motor Draw at 220V 11.9 Amps

Circuit Requirements

Only connect your machine to a circuit that meets the requirements below. Always check to see if the wires and circuit breaker in your circuit are capable of handling the amperage draw from your machine, as well as any other machines that could be operating on the same circuit. If you are unsure, consult a qualified electrician.

Minimum Circuit Requirement 15 Amp

Plug/Receptacle Type

Recommended Plug/Receptacle..... NEMA 6-15

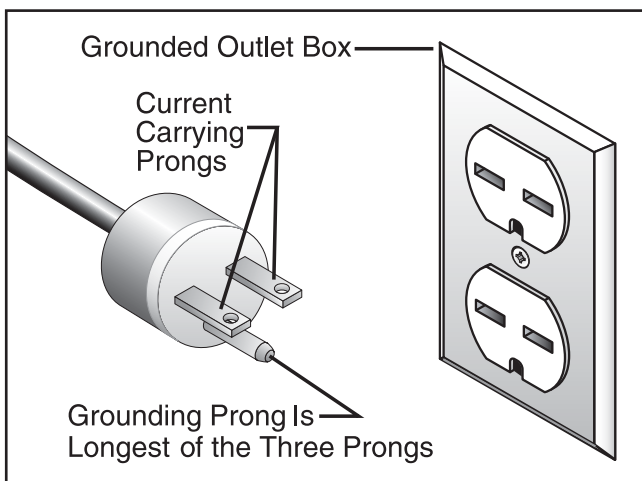
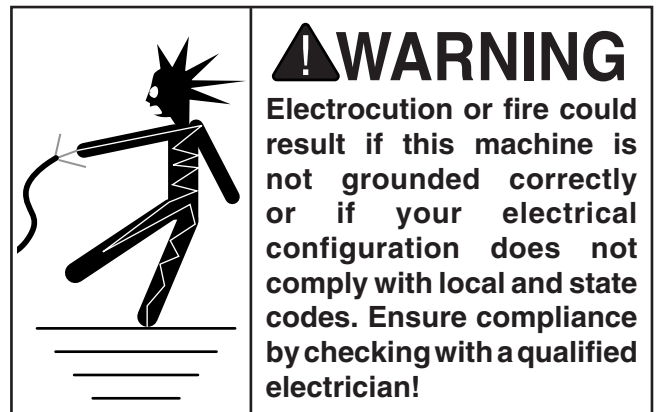

Figure 1. NEMA 6-15 plug and receptacle.

Grounding

In the event of an electrical short, grounding reduces the risk of electric shock. The grounding wire in the power cord must be properly connected to the grounding prong on the plug; likewise, the outlet must be properly installed and grounded. All electrical connections must be made in accordance with local codes and ordinances.



Extension Cords

We do not recommend the use of extension cords on 220V equipment. Instead, arrange the placement of your equipment and the installed wiring to eliminate the need for extension cords.

If you find it absolutely necessary to use an extension cord at 220V with your machine, check with a qualified electrician for the correct sizing, type, and maximum possible length for your needs.



SECTION 3: SET UP

Set Up Safety

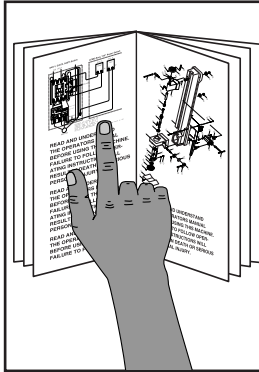

!WARNING

This machine presents serious injury hazards to untrained users. Read through this entire manual to become familiar with the controls and operations before starting the machine!

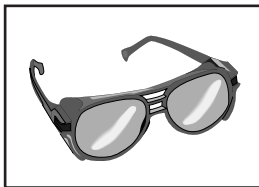

!WARNING

Wear safety glasses during the entire set up process!

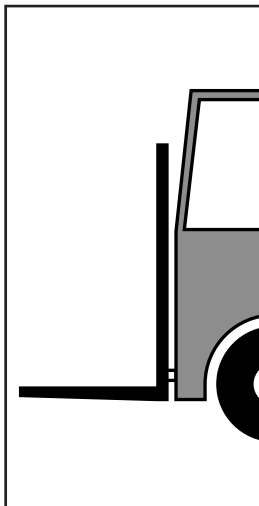

!WARNING

The Model G4016 is a heavy machine with a shipping weight over 1300 lbs. Serious personal injury may occur if safe moving methods are not followed. To be safe, get assistance and use power equipment when moving the crate and removing the machine from the crate.

Items Needed for Set Up

The following items are needed to complete the set up process, but are not included with your machine:

Description	Qty
• Safety Glasses (for each person)	1
• Power Lifting Equipment	1
• Lifting Straps (1500 lb capacity).....	2
• An Assistant	1
• Shop Rags for Cleaning	1
• Cleaning Solvent	1
• Precision Level	1
• Power Cord (length as needed)	1
• NEMA 6-15 Plug	1

Unpacking

The Model G4016 was carefully packed when it left our warehouse. If you discover the machine is damaged after you have signed for delivery, *please immediately call Customer Service at (570) 546-9663 for advice.*

Save the containers and all packing materials for possible inspection by the carrier or its agent. *Otherwise, filing a freight claim can be difficult.*

When you are completely satisfied with the condition of your shipment, you should inventory the contents.



Inventory

After all the parts have been removed from the boxes, you should have the following items:

Main Contents (Figure 2)		Qty
A.	Model G4016 Gear Head Lathe.....	1
B.	3-Jaw Chuck (Mounted on Lathe).....	1
C.	Steady Rest (Mounted on Lathe).....	1
D.	Follow Rest (Not Shown).....	1
E.	Bases (In their own boxes, not shown).....	2

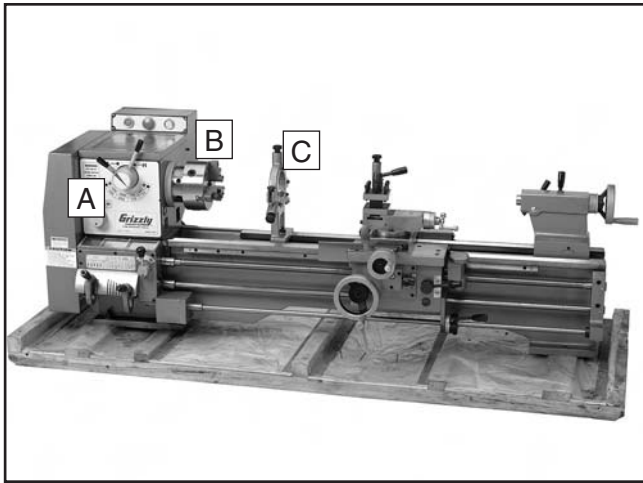

Figure 2. Main crate contents.

Loose Items (Figure 3)		Qty
F.	Kick Plate with Support Brackets (Not Shown).....	1
G.	12" Faceplate.....	1
H.	8" Four-Jaw Universal Chuck with Key.....	1
	Camlock Studs with Set Screws.....	3
I.	Chip Tray.....	1
J.	Backsplash.....	1

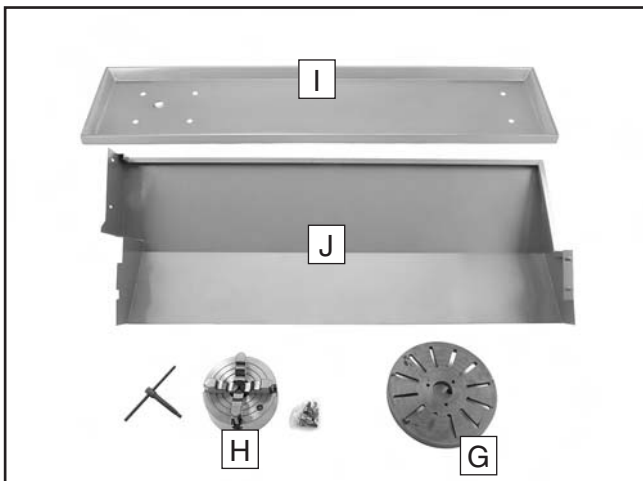

Figure 3. Loose item inventory.

Tool Box Contents (Figure 4)		Qty
K.	Handwheel Handles.....	3
L.	Oiler.....	1
M.	Drill Chuck with Key B16.....	1
N.	Live Center.....	1
O.	Wrench for Tool Post with Handle.....	1
P.	Large Chuck Key with Handle.....	1
Q.	Spindle Sleeve Adapter.....	1
R.	Drill Chuck Arbor B16/MT3.....	1
S.	#3 Morse Taper Dead Centers.....	2
T.	Phillips and Flat Head Screwdrivers.....	1 Ea
U.	Hex Wrenches 2.5, 3, 4, 5, 6, & 8 mm..	1 Ea
V.	Open-End Wrenches.....	1 Ea
	9/11, 10/12, 12/14, & 17/19mm.....	1 Ea
W.	Chuck Key (3-jaw & spindle).....	1
X.	Gear, Metric Threading.....	1
Y.	Brass Dowel.....	2
Z.	Hardware Bag (Not Shown).....	1
	—Flat Washers 12mm.....	6
	—Hex Bolts M12-1.75 x 45.....	6
	—Phillips Head Screws M6-1 x 10.....	16
	—Lock Washers 6mm.....	4
	—Hex Nuts M6-1.....	6

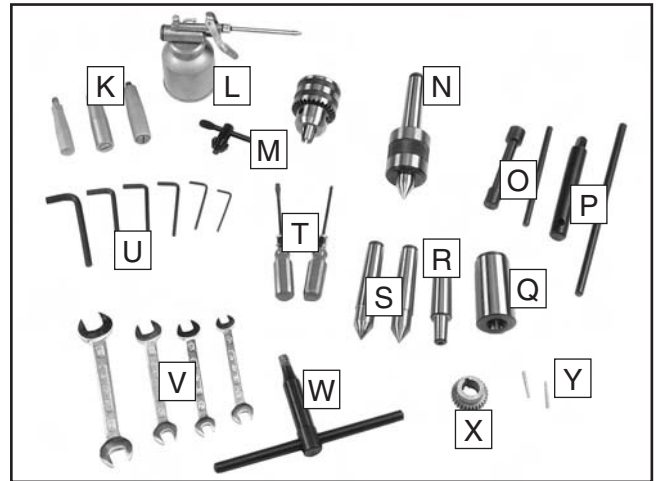

Figure 4. Toolbox contents.

In the event that any nonproprietary parts are missing (e.g. a nut or a washer), we would be glad to replace them, or for the sake of expediency, replacements can be obtained at your local hardware store.



Hardware Recognition Chart

USE THIS CHART TO MATCH UP
HARDWARE DURING THE ASSEMBLY
PROCESS!

MEASURE BOLT DIAMETER BY PLACING INSIDE CIRCLE

- #10
- 1/4"
- 5/16"
- 3/8"
- 7/16"
- 1/2"

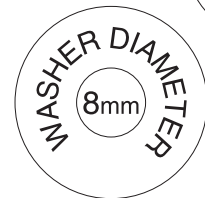
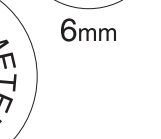
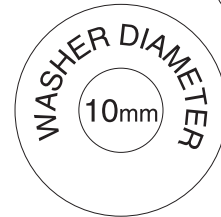
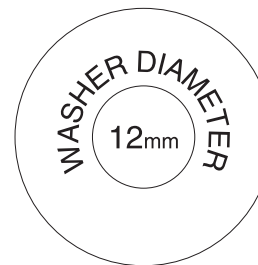
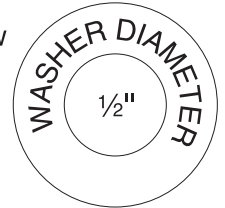
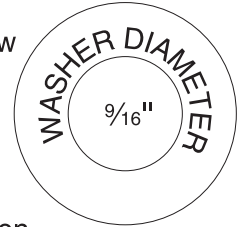
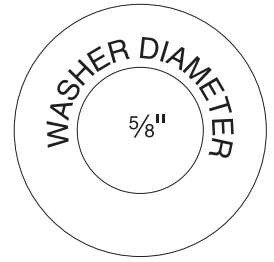
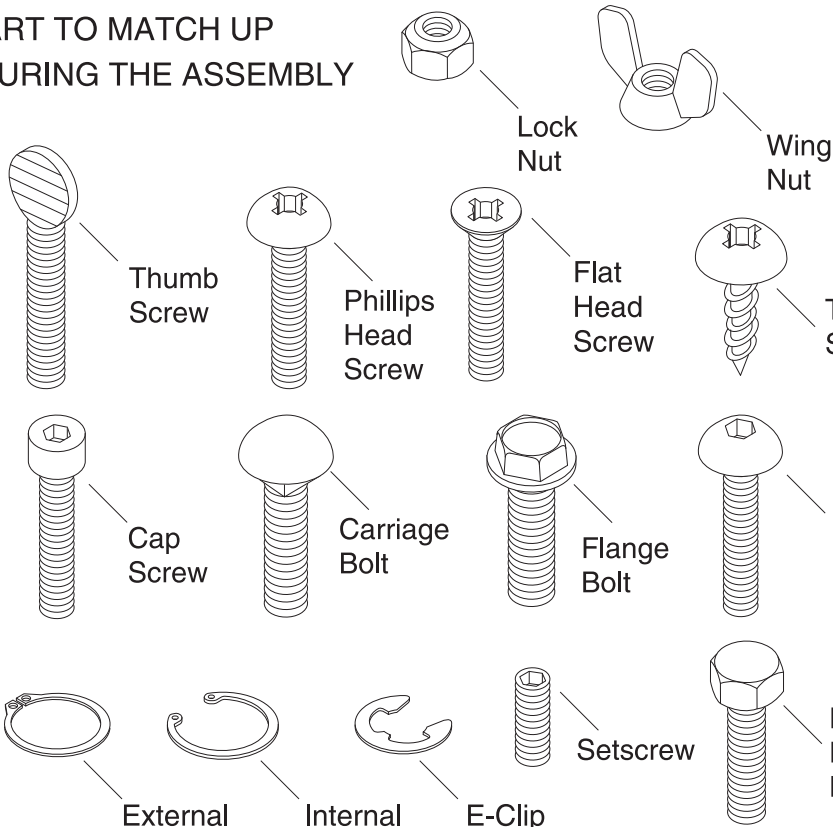

#10

WASHERS ARE MEASURED BY THE INSIDE DIAMETER

- 4mm
- 6mm
- 8mm
- 10mm
- 12mm
- 16mm

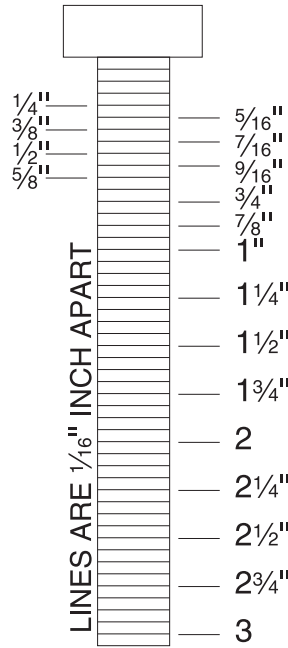
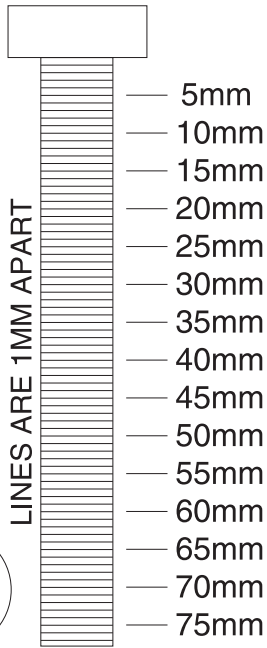

Clean Up

The unpainted surfaces are coated with a waxy oil to protect them from corrosion during shipment. Remove this protective coating with a solvent cleaner or citrus-based degreaser such as Grizzly's G7895 Degreaser. To clean thoroughly, some parts may need to be removed. **For optimum performance from your machine, make sure you clean all moving parts or sliding contact surfaces that are coated.** Avoid lacquer thinner and chlorine-based solvents, such as acetone or brake parts cleaner, as they may damage painted surfaces should they come in contact. Always follow the manufacturer's instructions when using any type of cleaning product.

	<p>⚠️ WARNING Gasoline and petroleum products have low flash points and could cause an explosion or fire if used to clean machinery. DO NOT use gasoline or petroleum products to clean the machinery.</p>
--	--

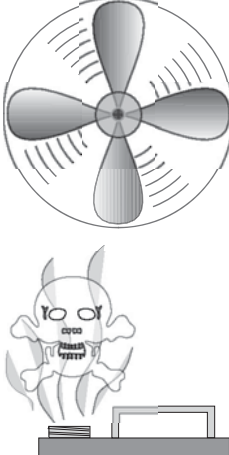
	<p>⚠️ CAUTION Many of the solvents commonly used to clean machinery can be toxic when inhaled or ingested. Lack of ventilation while using these solvents could cause serious personal health risks or fire. Take precautions from this hazard by only using cleaning solvents in a well ventilated area.</p>
---	--

Site Considerations

Floor Load

The Model G4016 weighs 1261 lbs. and has a base footprint of 71" W x 22" D. Most commercial floors are suitable for your machine. Some residential floors may require additional reinforcement to support both the machine and operator.

Working Clearances

Consider existing and anticipated needs, size of material to be processed through each machine, and space for auxiliary stands, work tables or other machinery when establishing a location for your lathe. See **Figure 5** for the minimum working clearances of the Model G4016.

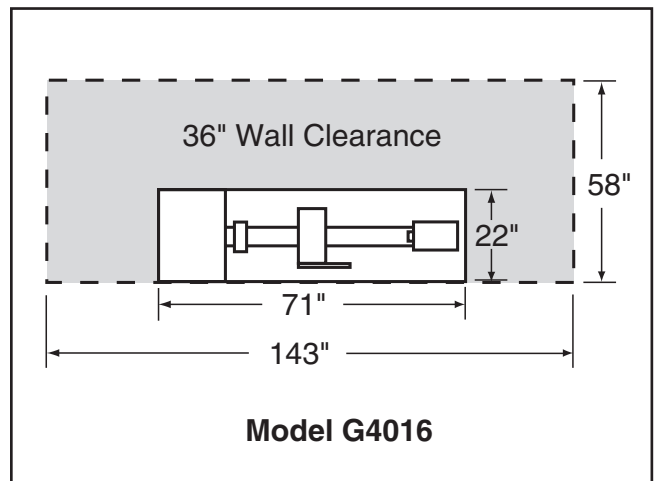
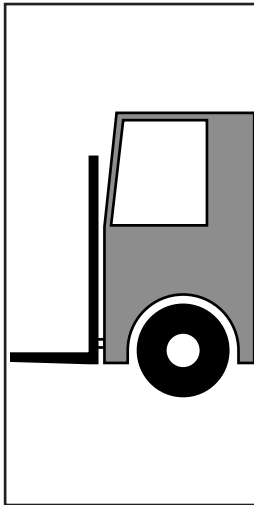

Figure 5. Working clearances.

	<p>⚠️ CAUTION Unsupervised children and visitors inside your shop could cause serious personal injury to themselves. Lock all entrances to the shop when you are away and DO NOT allow unsupervised children or visitors in your shop at any time!</p>
--	--



Lathe Assembly and Placement



!WARNING

The Model G4016 is a heavy machine that weighs 1261 lbs. Serious personal injury may occur if safe moving methods are not followed. To be safe, you will need assistance and power equipment when moving the shipping crate and removing the machine from the crate.

Components and Hardware Needed:	Qty
Bases	2
Model G4016 Gear Head Lathe	1
Kick Plate and Support Brackets.....	1
Chip Tray	1
Backsplash	1
Handwheel Handles	3
Flat Washers 12mm	6
Hex Bolts M12-1.75 x 45.....	6
Phillips Head Screws M6-1 x 10.....	16
Hex Nuts M6-1	6
Lock Washers 6mm.....	4

To assemble the lathe components:

1. Remove the stands from their boxes and place them at the site chosen for the lathe.
2. Attach the kick plate brackets to the stand with M6-1 x 10 Phillips head screws and attach the kick plate to the brackets with the remaining screws and hex nuts.
3. Place the chip tray on top of the stands. Line up the holes in the tray with the holes on top of the stands.

!WARNING

Use webbing slings with a minimum of 1500 lb. capacity. Serious injury or death could occur if the slings break and the lathe falls.

4. Prevent damage to the lead screw, feed rod, or ON/OFF rod by threading the slings between the bedway and the rods (**Figure 6**). Adjust the balance by moving the carriage.

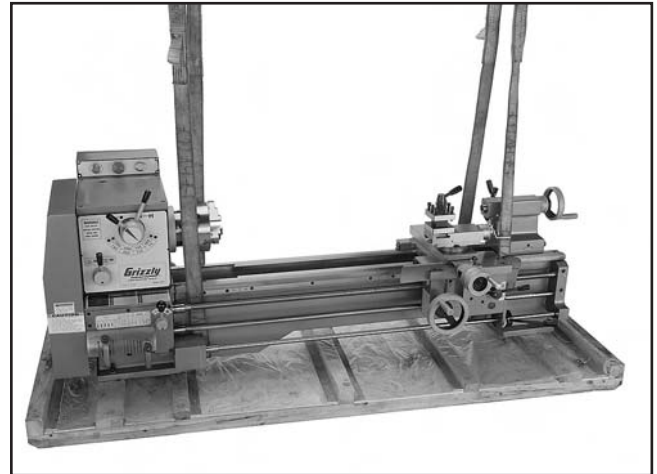

Figure 6. Lifting method for lathe.

5. Use a fork lift or an overhead crane to lift the lathe off the crate and over the stands.
6. Line up the holes in the base of the lathe with the stand holes and slowly lower the lathe into place. Thread the M12-1.75 x 45 hex bolts with washers through the holes in the lathe, chip tray, and the stand.
7. Attach the backsplash to the lathe using the fasteners already in the lathe.
8. Thread the tailstock, longitudinal (**Figure 7**), and crossfeed handles into the handwheels.

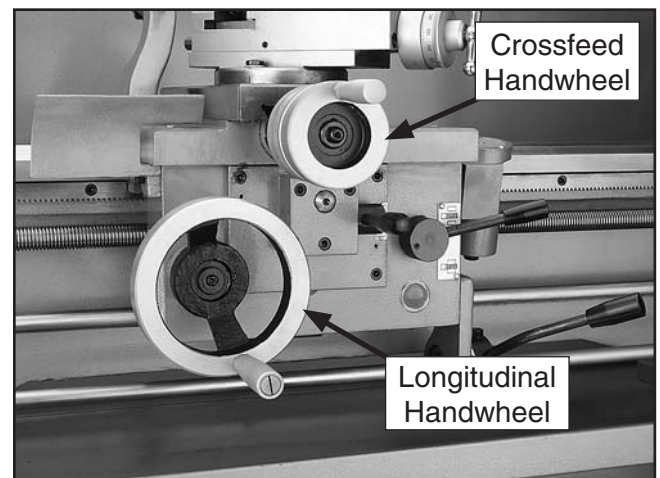

Figure 7. Longitudinal and crossfeed handle locations.



Mounting to Shop Floor

Although not required, we recommend that you mount your new machine to the floor. Because this is an optional step and floor materials may vary, floor mounting hardware is not included. Generally, you can either bolt your machine to the floor or mount it on machine mounts. Both options are described below. Whichever option you choose, it is necessary to level your machine with a precision level.

Bolting to Concrete Floors

Lag shield anchors with lag bolts (**Figure 8**) and anchor studs (**Figure 15**) are two popular methods for anchoring an object to a concrete floor. We suggest you research the many options and methods for mounting your machine and choose the best that fits your specific application.

NOTICE

Anchor studs are stronger and more permanent alternatives to lag shield anchors; however, they will stick out of the floor, which may cause a tripping hazard if you decide to move your machine.

Using Machine Mounts

Using machine mounts, shown in **Figure 10**, gives the advantage of fast leveling and vibration reduction. The large size of the foot pads distributes the weight of the machine to reduce strain on the floor.

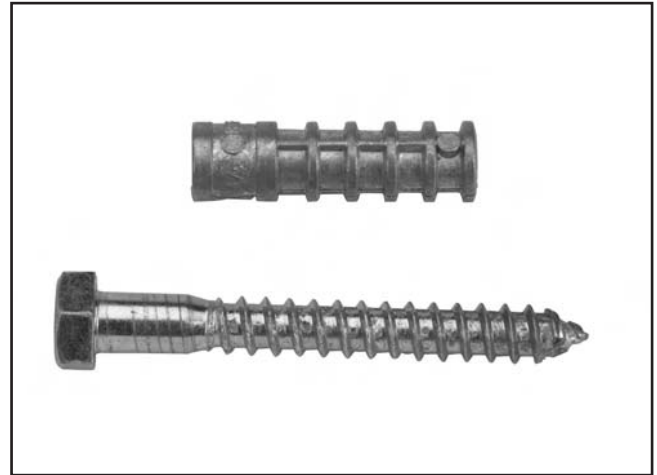

Figure 8. Typical lag shield anchor and lag bolt.

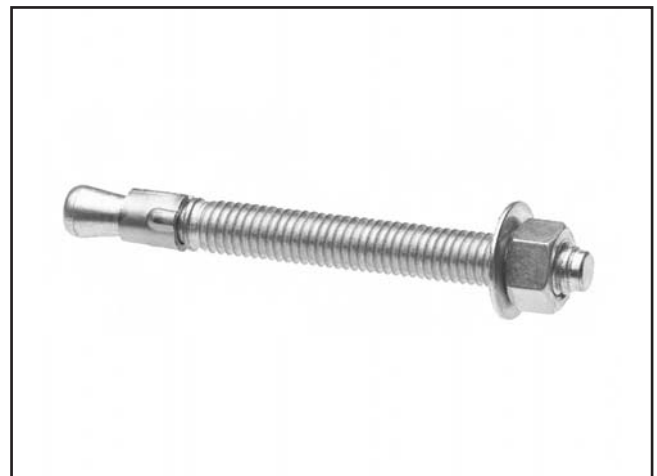

Figure 9. Typical anchor stud.



Figure 10. Machine mount example.



Power Cord

Components and Hardware Needed:	Qty
Power Cord (Not Included).....	1

Before installing the power cord, read through **SECTION 2: CIRCUIT REQUIREMENTS** to check that your setup follows the safety and circuit requirements, and the power cord and power disconnect that you have chosen meet the requirements for this machine.

To connect the sander to the power source:

1. Open the electrical box on the back of the lathe.
2. Feed the power cord through the strain relief on the bottom of the electrical box then tighten the strain relief. Make sure there is enough slack in the power cord to reach the terminal block.
3. Connect the cord to the L, N, and ground terminals shown in **Figure 11**, and close the electrical box.

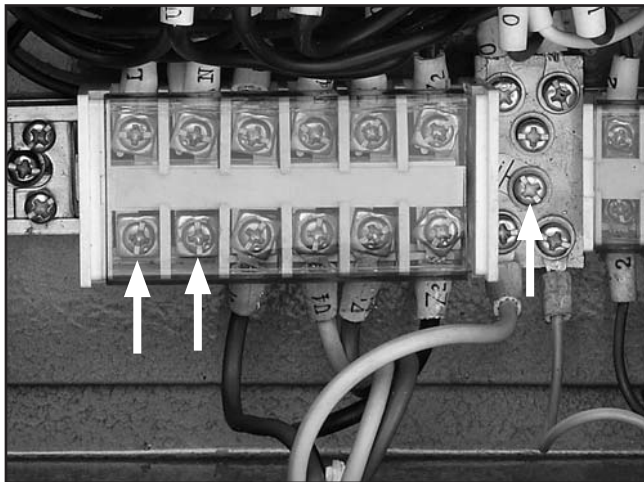

Figure 11. G4016 power cord wiring.

4. Install a NEMA 6-15 plug or hardwire the power cord into a power disconnect box.

Check Gear Oil

It is important to make sure the gear box has oil in it before running the lathe for the first time. This is to ensure the gears do not burn up. Fill the headstock and apron with SAE 20W or an ISO 68 non-detergent gear oil or an equivalent lubricant.

To check the gear oil:

1. Inspect the oil sight glasses in the headstock and apron (see **Figures 12 & 13**). The oil level must be kept at the indicator marks.



Figure 12. Headstock oil sight location.

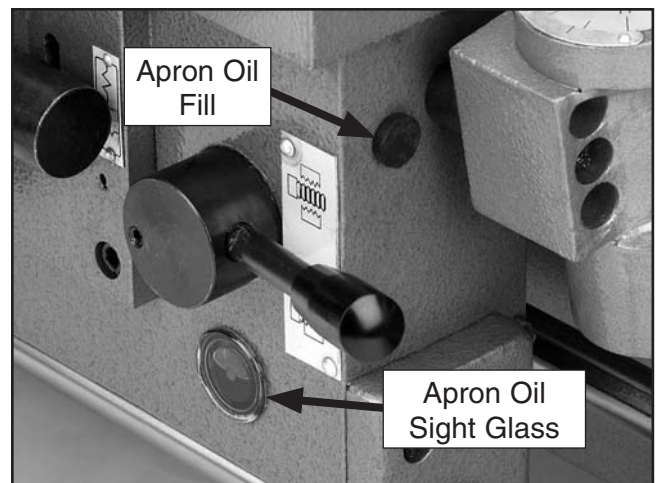
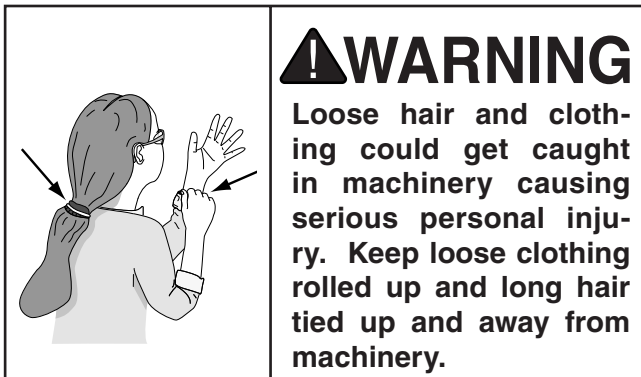

Figure 13. Apron oil sight and fill locations.

2. If necessary, fill the headstock and apron with SAE 20W or ISO 68 non-detergent gear oil, or an equivalent lubricant. The apron fill hole is shown in **Figure 13**, and the headstock fill hole is located on the top of the headstock.



Test Run



The purpose of the test run is to make sure the lathe/mill is wired correctly and the motor is working properly before proceeding with operations. Check to make sure that auto feed is not engaged and there are no loose parts around the spindles. Set the lathe to the slowest RPM before the test run. Refer to **Setting RPM** on **Page 34** and **Lubrication** on **Page 46** before doing the test run.

NOTICE

Check all oil levels and lubrication points before starting lathe. Failure to lubricate all moving parts will result in excessive wear.

Before starting the lathe:

1. Read the entire manual and make sure you take all safety precautions before operating this lathe.
2. Inspect the oil sight glasses in the headstock and apron and fill if they are low.
3. Make sure all tools or foreign objects have been removed from in and around the lathe.
4. Make sure all the wiring is correct.
5. Make sure the spindle ON/OFF switch shown in **Figure 14** is in the center position (OFF).

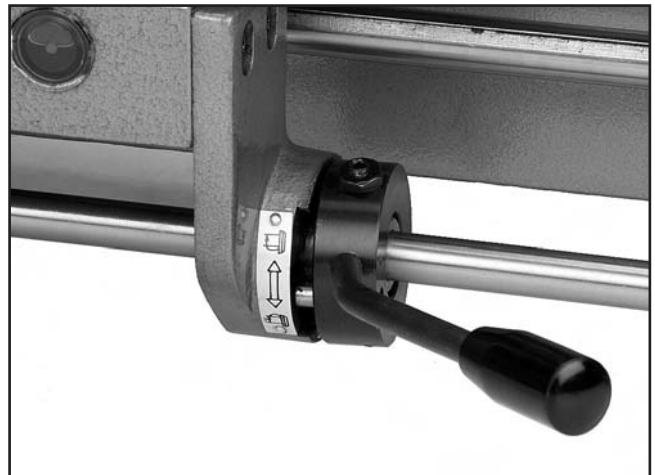

Figure 14. Spindle switch in the OFF position.

6. Set the spindle speed to the lowest RPM, refer to **Setting RPM** on **Page 34**.

To start the lathe:

1. **Wear safety glasses at all times when running the lathe!**
2. Connect the lathe to the power source.

Note: Once plugged in, the lathe always has power. The green "Power" light shown in **Figure 15** will be lit to indicate a live connection unless the EMERGENCY STOP button is pushed in. To cut power to the machine entirely, you will need to unplug or disconnect the lathe from the power source.



3. Rotate the EMERGENCY STOP button (**Figure 15**) in the direction of the arrows on the button and allow it to pop out.

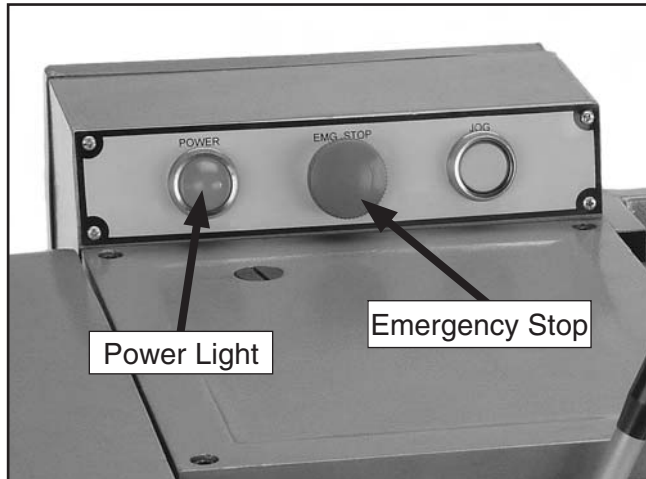

Figure 15. Power light and emergency stop locations.

4. Turn the spindle ON/OFF switch shown in **Figure 14** to the right and up for clockwise spindle rotation, and to the right and down for counterclockwise rotation.
5. Return the spindle ON/OFF switch to the center position and wait for the machine to come to a complete stop.

The lathe should run smoothly, with little or no vibration or rubbing noises. Strange or unnatural noises should be investigated and corrected before operating the lathe further.

If the lathe seems to be running correctly, let it run for a short time to ensure that the moving parts are working properly with no excessive vibration. DO NOT operate the lathe if problems cannot be corrected.

If you cannot locate the source of unusual noises, refer to **Troubleshooting**, and feel free to contact our Technical Support Department at (570) 546-9663.

Spindle Break-in Procedures

NOTICE

Failure to follow start up and spindle break-in procedures will likely cause rapid deterioration of spindle and other related parts.

It is essential to closely follow the proper break-in procedures to ensure trouble free performance. Complete this process once you have familiarized yourself with all instructions in this manual.

To perform the break-in procedure:

1. Follow all lubrication procedures highlighted in **Lubrication** on **Page 46** of this manual.
2. Turn the spindle ON/OFF switch shown in **Figure 14** to the right and up for clockwise spindle rotation, and to the right and down for counterclockwise rotation.
3. Turn the lathe **ON** and let it run for a minimum of 10 minutes in the clockwise direction and another 10 minutes in the counterclockwise direction.
4. Turn the lathe **OFF**, change gears to the next highest RPM (see **Setting RPM** on **Page 34**) and repeat **Step 3** for each RPM setting.



SECTION 4: OPERATIONS

Operation Safety

!WARNING

Damage to your eyes, lungs, and ears could result from using this machine without proper protective gear. Always wear safety glasses, a respirator, and hearing protection when operating this machine.

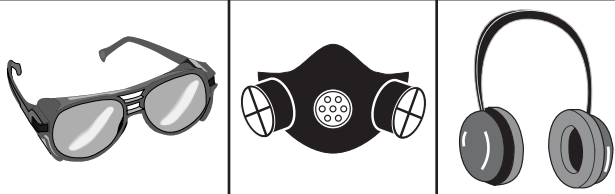

!WARNING

Loose hair and clothing can get caught in machinery and cause serious personal injury. Keep loose clothing and long hair away from moving machinery.

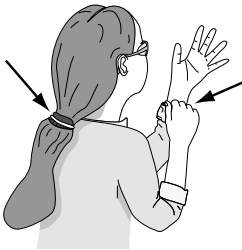

NOTICE

This manual is written with the expectation that the operator has the knowledge and skills to use this machine. If you have never used this type of machine or equipment before, we strongly recommend that you read instruction books and get formal training before operating this machine.

This machine will perform many types of operations that are not covered in this manual. Many of these operations can be dangerous or deadly if performed incorrectly. If at any time you are experiencing difficulties performing any operation, stop using the machine! Regardless of the content in this manual, Grizzly Industrial will not be held liable for accidents caused by lack of training.

Three-Jaw Scroll Chuck

The three-jaw scroll chuck included with this lathe features hardened steel jaws that center the workpiece within 0.002"-0.003". These jaws are reversible for chucking large diameter workpieces. This chuck uses three cam-lock studs to tighten the chuck against the spindle nose.

To remove or mount the three-jaw direct mount scroll chuck, you will need the following tools:

- Chuck Key
- Dead Blow Hammer
- A Chuck Cradle or a piece of plywood large enough to span the bedways and support the weight of the chuck
- Breaker Bar (optional)

!WARNING

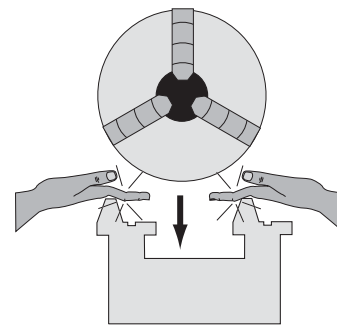

PINCH HAZARD! Protect your hands and the precision ground bedways with plywood or a chuck cradle when removing the lathe chuck! The heavy weight of a falling chuck can cause serious injury.



To remove the chuck:

1. Unplug the lathe!

2. Lay a chuck cradle or a layer of plywood over the bedways to protect the precision ground surfaces from damage and to prevent fingers from being pinched (see **Figure 16**).

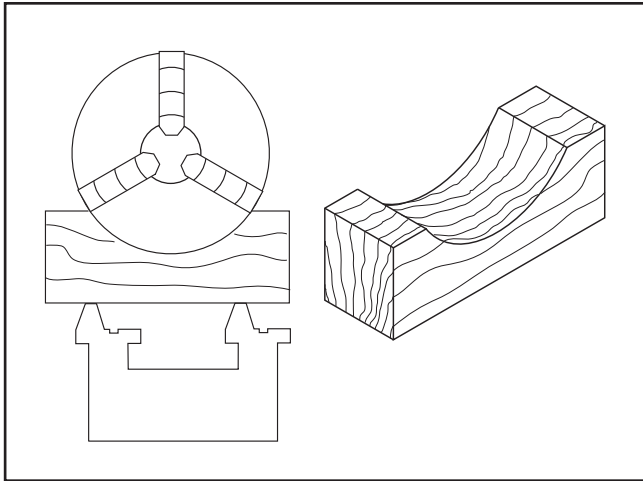

Figure 16. Simple chuck cradle made of scrap lumber.

3. Loosen the cam-locks by turning the chuck key counterclockwise approximately one-third of a turn until the mark on the cam-lock aligns with the single mark on the spindle nose in **Figure 17**. If the cam-lock stud does not freely release from the cam-lock, wiggle the cam-lock until the cam-lock stud releases.

Note: *These cam-locks may be very tight. A breaker bar may be used to add leverage.*

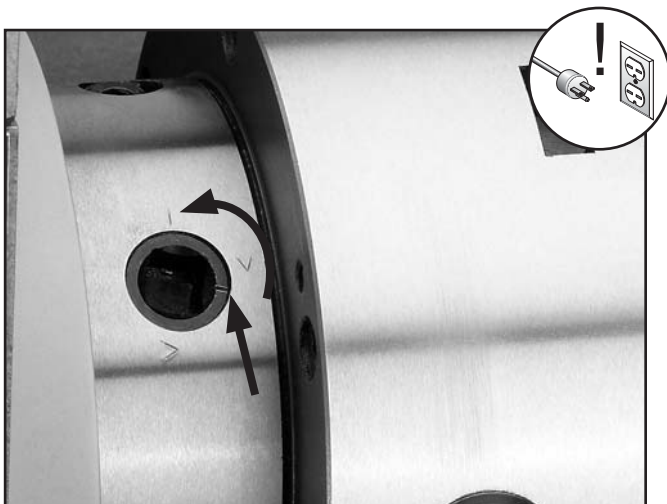

Figure 17. Indicator arrows.

4. Using a dead blow hammer or other soft mallet, lightly tap around the outer circumference of the chuck body to break the chuck free from the cam-locks and from the spindle nose taper.
5. With a rocking motion, carefully remove the chuck from the spindle nose (see **Figure 18**).

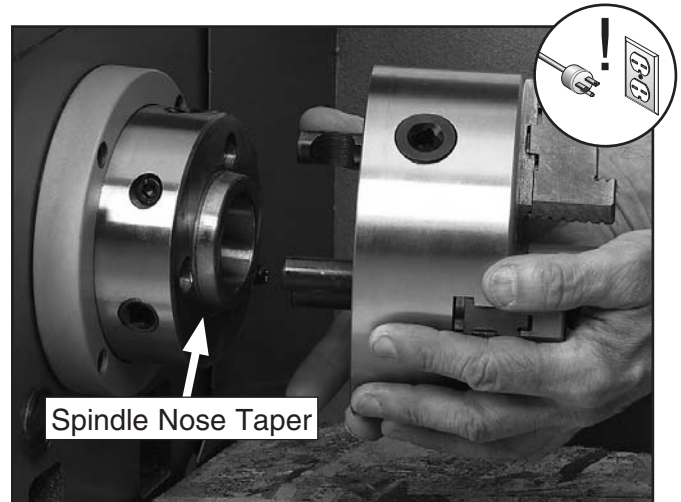

Figure 18. Installing and removing chuck.

⚠ WARNING

Large chucks are very heavy. Always get assistance when removing or installing large chucks to prevent personal injury or damage to the chuck or lathe.



To install the three-jaw scroll chuck:

1. **Unplug the lathe!**
2. Lay a chuck cradle or protective layer of plywood over the bedways to protect the precision ground surfaces from damage and to prevent fingers from being pinched.
3. If the three-jaw scroll chuck does not have the cam-lock studs assembled, screw the cam-lock studs into the chuck body.
4. Using your calipers, measure the height of the cam-lock studs from the previously installed chuck (see **Figure 19**).



Figure 19. Measuring height of cam-lock studs.

5. Adjust the cam-lock studs in the three-jaw chuck to match the measurement from the previous chuck.

Note: *Trial-and-error adjustment will be needed if you do not have a previous cam-lock stud to reference.*

6. Once the proper length is obtained, thread in the cap screws to lock the cam-lock studs into position.

7. Lift the chuck, and insert the studs onto the spindle nose (see **Figure 18**).
8. Tighten each cam-lock clockwise until you feel the cam-lock engage the cam-lock stud. Continue to turn until you can't turn any further. You will see the chuck body draw-up to the spindle nose. Ideally the cam-lock mark will fall between the two pointed arrows on the spindle nose (see **Figure 20**).

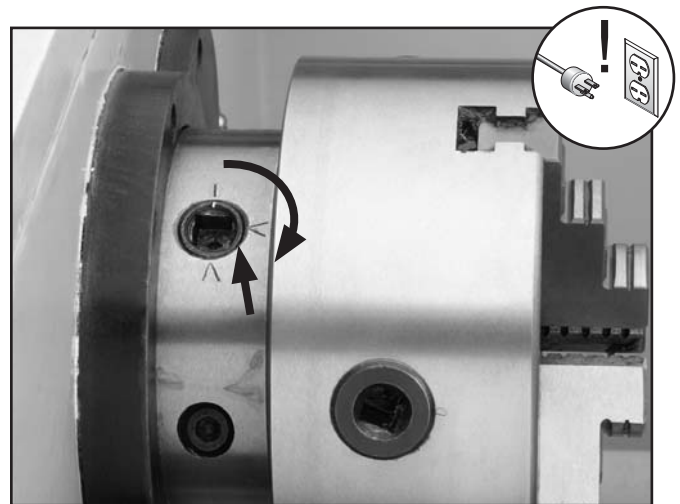

Figure 20. Tightening the cam-locks.



To load a workpiece:

1. With the chuck key, open the jaws so the workpiece lays flat against the chuck face and jaw step, or fits in the through hole. For jaw and work holding options, see **Figure 21**.

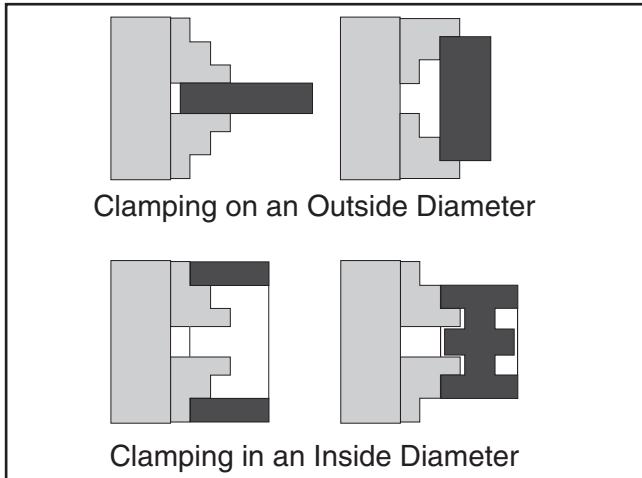

Figure 21. Loading a workpiece.

2. Close the jaws until they make contact with the workpiece.
3. Turn the chuck by hand to make sure you have even contact with all three jaws and the workpiece is centered.

—If the workpiece is off center, loosen the jaws and adjust the workpiece.

—If the workpiece is centered, tighten the jaws.

<p>! WARNING Securely clamp your workpiece and remove the chuck key! Thrown objects from a lathe can cause serious injury or death to the operator and to bystanders many feet away.</p>	
---	--

Reversing Jaws

The jaws of the three-jaw chuck are reversible to accommodate different workpieces. The jaws hold the workpiece by the outer diameter in the outside configuration. The inside configuration holds larger work from the inside and holds smaller work from the outside when held in the center (see **Figure 21**).

To reverse the jaws:

1. Remove the cap screws (**Figure 22**) from one of the jaws with an 8mm hex wrench, then remove the jaw.

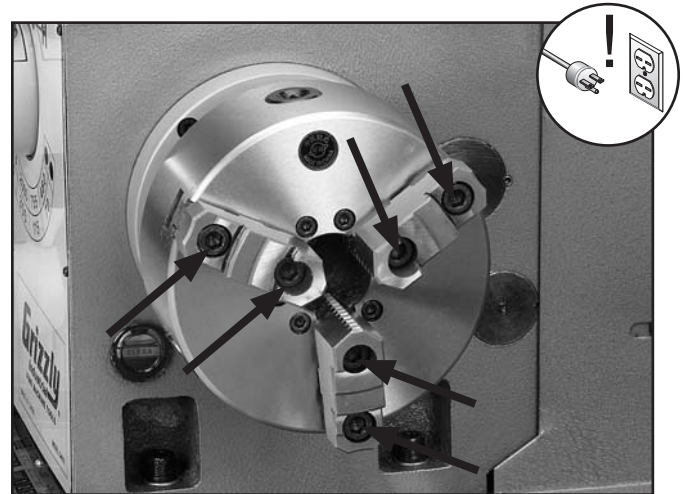

Figure 22. Cap screws securing the jaws.

2. Rotate the jaw 180° (**Figure 23**) and replace the cap screws. Make sure the longer cap screw remains in the thicker part of the jaw. Repeat with the remaining jaws.

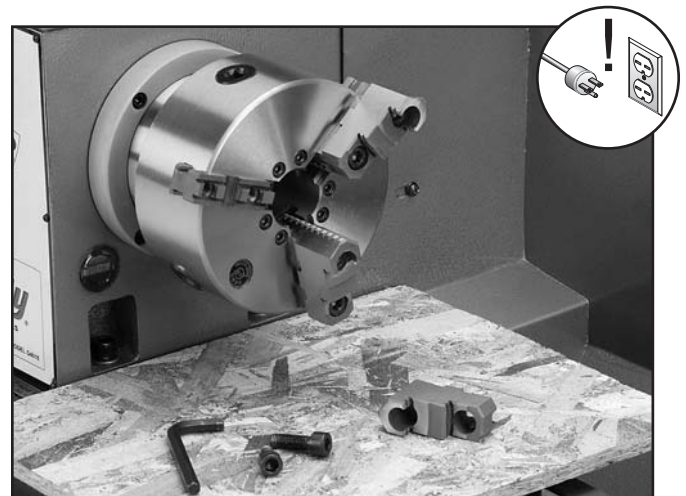

Figure 23. Reversing the chuck jaws.



Four-Jaw Independent Chuck

Four-jaw chucks feature independently adjustable hardened steel jaws. Each jaw can be removed from the chuck body and reversed for a wide range of work holding versatility.

Install the four-jaw chuck according to the instructions for three-jaw chucks found on **Page 22**.

!WARNING

Large chucks are very heavy. Always have assistance when removing or installing large chucks to prevent personal injury or damage to the chuck or lathe.

To load a workpiece:

1. Open each jaw with the chuck key until the workpiece can lie flat against the chuck face.
2. Support the workpiece and slide the dead center in the tailstock against the workpiece, then lock the tailstock. For more information, refer to **Tailstock** on **Page 28** and **Centers** on **Page 29**.
3. Turn the tailstock quill so the dead center applies enough pressure to the center point of your workpiece to hold it in place (**Figure 24**), then lock the tailstock quill.

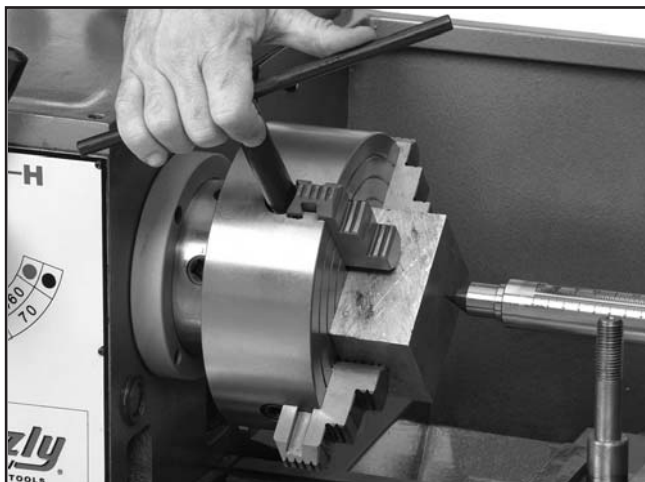

Figure 24. Centering workpiece (toolpost removed for clarity.).

4. Turn each jaw until it just makes contact with the workpiece.
5. Tighten each jaw in small increments. After adjusting the first jaw, continue tightening in opposing sequence (see **Figures 24 & 25**). Check frequently to make sure you have not wandered off your center point due to applying too much pressure to a single jaw.

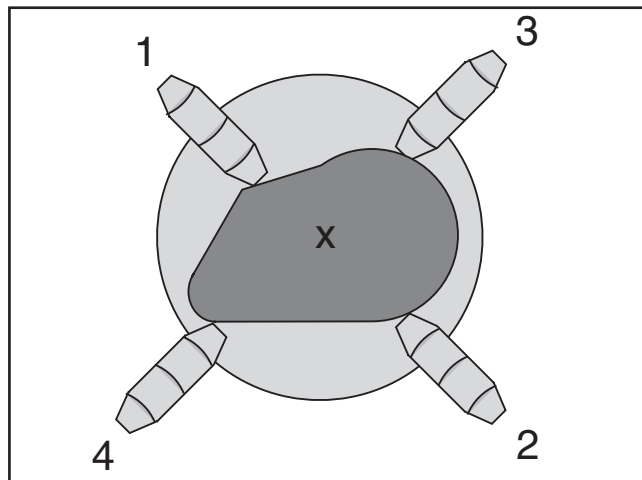

Figure 25. Jaw tightening sequence.

6. After the workpiece is held in place, back the tailstock away and rotate the chuck by hand. The center point will move if the workpiece is out of center (see **Figure 26**).

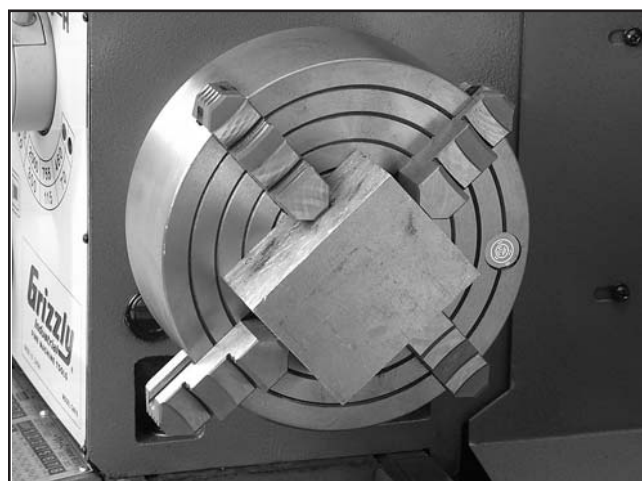

Figure 26. Properly held workpiece for offset machining at low RPM.

7. Make fine adjustments by slightly loosening one jaw and tightening the opposing jaw until the workpiece is precisely aligned.
8. Use low RPMs when machining heavy eccentric workpieces.



Faceplate

The faceplate is used to turn non-cylindrical parts and for off-center turning. Install the faceplate according to the instructions for three-jaw chucks found on **Page 22**.

To load a workpiece:

1. Support the workpiece and slide the dead center in the tailstock against the workpiece, then lock the tailstock. For more information, refer to **Tailstock** on **Page 28** and **Centers** on **Page 29**.
2. Turn the tailstock quill so the dead center applies enough pressure to the center point of your workpiece to hold it in place.
3. Lock the tailstock quill when sufficient pressure is applied to hold the workpiece in place. Additional support may be needed, depending on the workpiece.

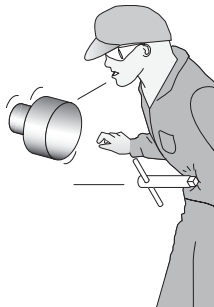
<p>! WARNING Securely clamp your workpiece and remove the chuck key! Thrown objects from a lathe can cause serious injury or death to the operator and to bystanders many feet away.</p>	
---	---

4. Secure the workpiece with a minimum of three independent clamping devices (see **Figure 27**). Failure to follow this step may lead to deadly injury to yourself or bystanders. Take into account rotation and the cutting forces applied to the workpiece when clamping to the faceplate. **Make sure your clamping application will not fail!**

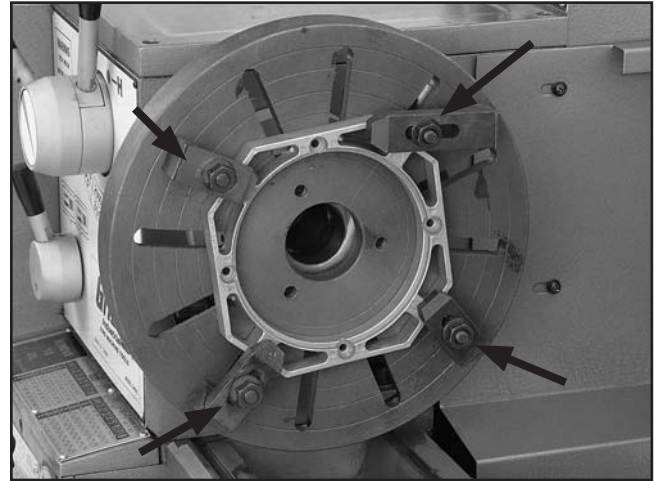

Figure 27. Faceplate with properly clamped workpiece in four locations.

<p>! WARNING Use a minimum of three independent clamping devices when using faceplate. Failure to provide adequate clamping will cause workpiece to eject.</p>

5. Use a lower RPM when machining heavy eccentric workpieces.



Tailstock

The tailstock (**Figure 28**) of the Model G4016 lathe can be used to support workpieces with the use of a live or dead center. It can drill or bore holes in the center of a part with a #3 tapered shank drill, or using a drill chuck fitted with a #3 taper and a drill. It can also be used for cutting shallow tapers by using the offset adjustment.

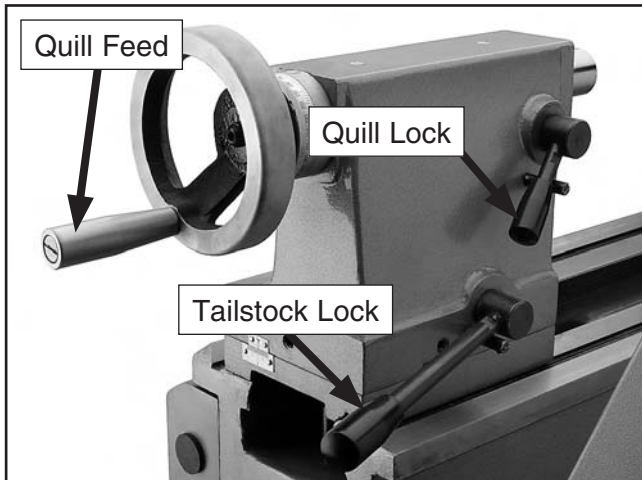

Figure 28. Tailstock and quill lock handles in locked position.

To operate the tailstock:

1. Slide the tailstock to the desired position.
2. Pull up on the tailstock lock handle to lock the tailstock in place.

To operate the tailstock quill:

1. With the tailstock locked, push down the quill lock handle to unlock.
2. Turn the quill feed handle clockwise to feed/move the quill towards the spindle, or counterclockwise to move it away from the spindle.
3. Pull up on the quill lock handle to lock the quill in place.

To install a tapered drill chuck:

1. With the tailstock locked, push down to unlock the quill lock handle.
2. Turn the quill feed handle clockwise to extend the quill about one inch.
3. Insert the tapered drill arbor (**Figure 29**) into the quill until the taper is firmly seated. The matching tapers hold the arbor.

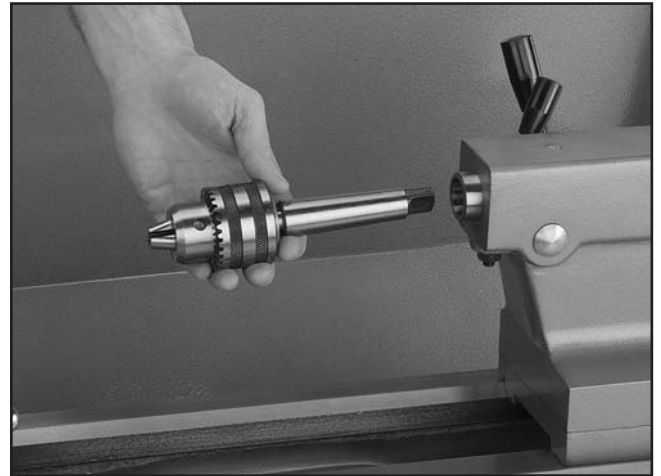

Figure 29. Setting up tailstock for drilling.

4. Turn the quill feed handle clockwise to feed the drill bit into the rotating workpiece.
5. To remove the chuck taper, turn the quill feed handle counterclockwise until the chuck is pushed out from the tailstock taper.



Centers

The Model G4016 lathe is supplied with a live center, an HSS MT3 dead center, and a carbide tipped MT3 dead center. The supplied MT5-3 sleeve fits into the spindle taper to hold an MT3 center.

The dead center is used in the tailstock to support workpieces. When used in the tailstock, make sure to keep the dead center tip and workpiece lubricated.

To install a dead or live center:

1. Feed the quill out about 1" so that the dead center can be inserted.
2. Insert the dead center into the quill opening (see **Figure 30**). Matching tapers provide the locking action.



Figure 30. Inserting dead center.

3. Move the tailstock into position and lock it in place.
4. Feed the quill into the workpiece.

Note: Make sure there is a center drilled hole in the end of the workpiece for the dead center.

5. Lock the quill into place once the live center and the part rotate together. The quill may need to be adjusted during operation.
6. To remove the dead center, retract the quill until the dead center pops free.

The dead center can also be used in the spindle. The most common application is when using the faceplate (see **Figure 31**).

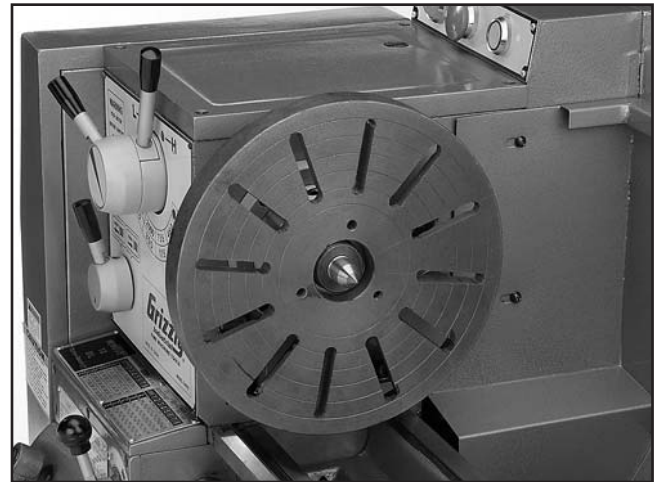

Figure 31. Faceplate and dead center setup.

To install the dead center in the spindle:

1. Remove the chuck from the spindle.
2. Install the dead center in the spindle sleeve.
3. Install the sleeve into the spindle opening.
4. Attach the faceplate to the spindle.

Note: When using the dead center in the spindle, use a lathe dog so that your part will rotate with the spindle and not spin on the dead center tip.

NOTICE

Failure to keep dead center point well lubricated will damage dead center and workpiece.



Cutting Shallow Tapers with Tailstock

To set up the tailstock to cut a shallow taper:

1. Lock the tailstock in position and loosen the set screw located on the end of the tailstock (see **Figure 32**).

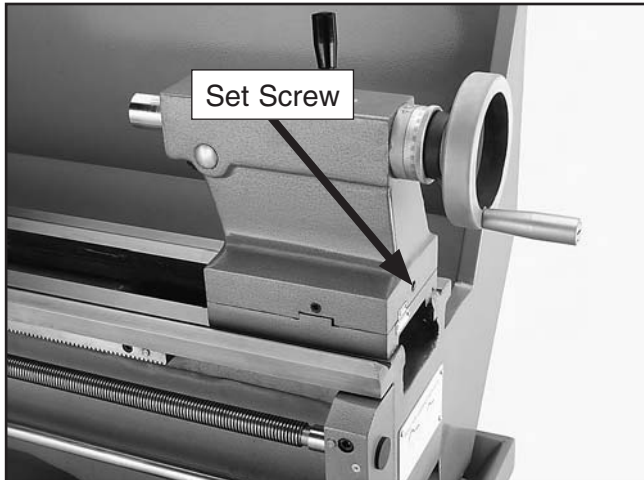

Figure 32. Tailstock off-set adjustments.

2. Alternately loosen and tighten the two adjustment screws until the desired offset is indicated on the offset scale (see **Figure 33**).

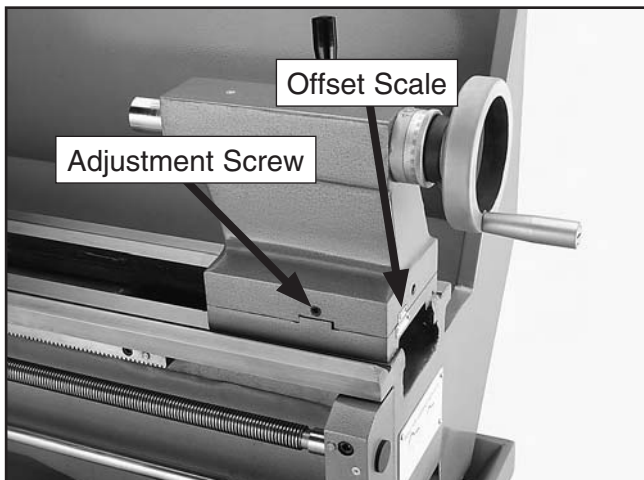

Figure 33. Offset scale.

3. Tighten the set screw located on the end of the tailstock to lock the setting.

To return the tailstock back to original position, repeat the process until the centered position is indicated on the scale.

Tailstock Alignment

The tailstock is aligned at the factory with the headstock. We recommend that you take the time to ensure that the tailstock is aligned to your own desired tolerances.

To align the tailstock:

1. Using an engineer's precision level on the bedways, make sure the lathe is level side-to-side and front-to-back. If the lathe is not level, correct this condition before proceeding.
2. Get two pieces of steel round stock, 2.00" in diameter x 6.00" long.
3. Center drill both ends of one piece of the round stock. Set it aside for use in **Step 6**.
4. Using the other piece of stock, make a dead center by turning a shoulder to make a shank. Flip the piece over in the chuck and turn a 60° point (see **Figure 34**).

Note: *As long as the dead center remains in the chuck, the point of your center will remain true to the spindle axis. Keep in mind that the point will have to be refinished whenever it is removed and returned to the chuck.*

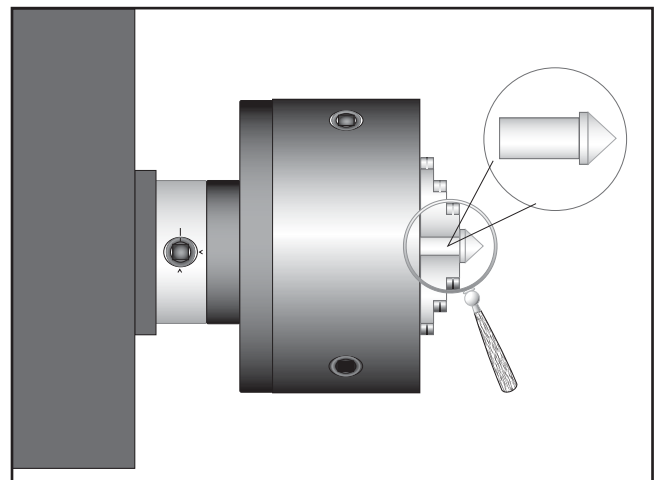

Figure 34. Tailstock centering dead center.



5. Place the live center in the tailstock.
6. Attach a lathe dog to the bar stock and mount it between centers (see **Figure 35**).

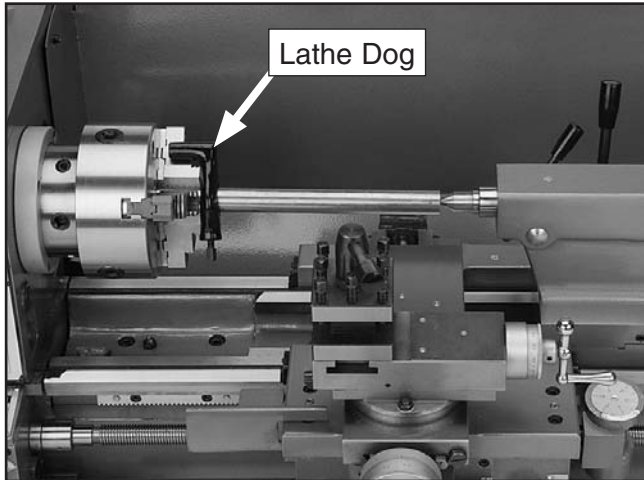

Figure 35. Checking tailstock alignment.

7. Turn approximately 0.010" off the diameter.
8. Mount a dial indicator so the dial plunger is on the tailstock barrel before making adjustments to the tailstock.

9. Measure the stock with a micrometer.

—If the stock is fat at the tailstock end, the tailstock needs to be moved toward the operator half the distance of the amount of the taper (see **Figure 36**).

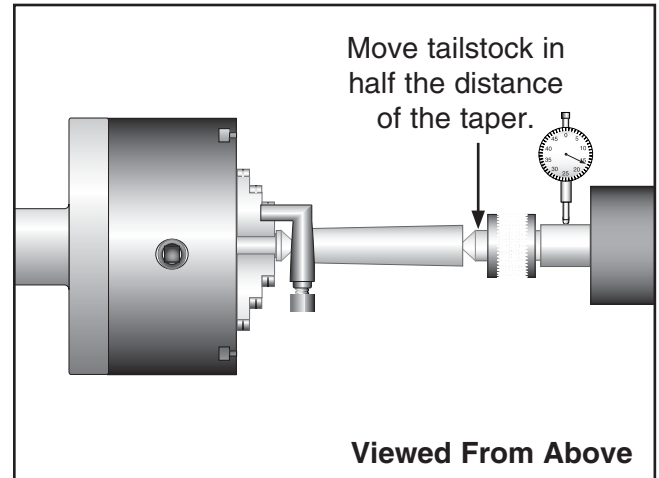

Figure 36. Tailstock adjustment option #1.

—If the stock is thinner at the tailstock end, the tailstock needs to be moved away from the operator half the distance of the amount of the taper (see **Figure 37**).

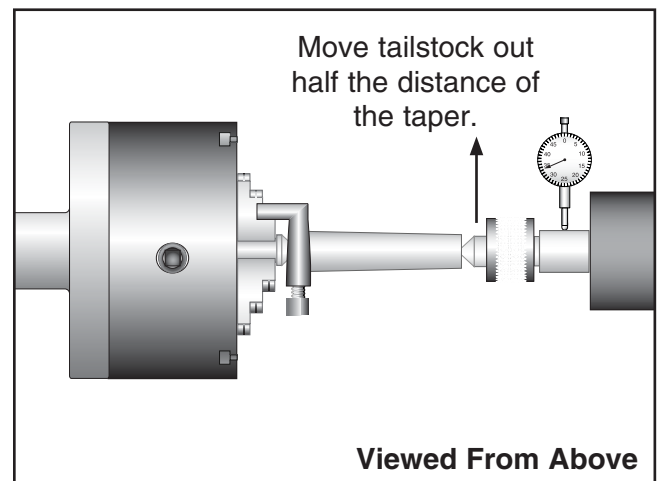

Figure 37. Tailstock adjustment option #2.

10. Refer to **Cutting Shallow Tapers with Tailstock** on **Page 30** for making adjustments to the tailstock center. Turn another 0.010" off of the diameter and check for a taper. Repeat this process as necessary until the desired amount of accuracy is achieved.



Steady Rest

The steady rest serves as a support for long shafts. The steady rest can be placed anywhere along the length of the part.

To install/use the steady rest:

1. Place the steady rest on the lathe bedways so the triangular notch fits over the angled portion of the rear bedway.
2. Loosen the three set screws so the finger position can be adjusted (see **Figure 38**).

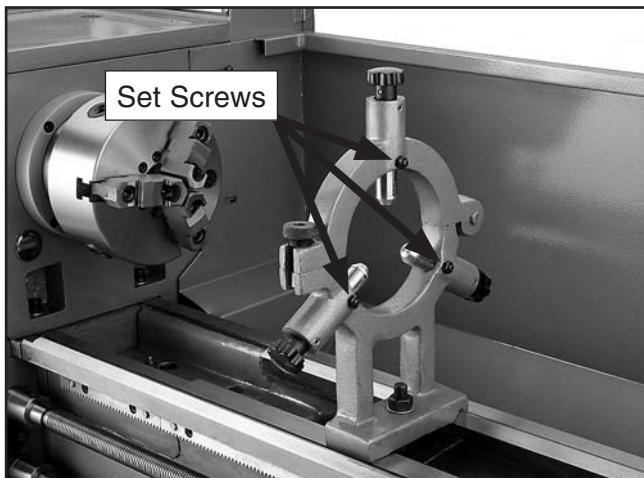

Figure 38. Steady rest adjustments.

3. Loosen the knurled screw and open the steady rest so a workpiece can fit inside (see **Figure 39**).

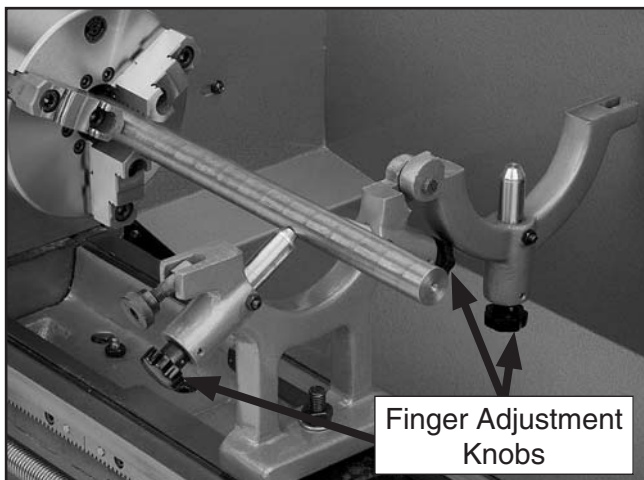

Figure 39. Positioning workpiece in steady rest.

4. Position the steady rest where desired. Tighten the bolt at the base of the steady rest to secure in place.
5. Close the steady rest so that the workpiece is inside the fingers and tighten the knob.
6. Set the fingers snug to the workpiece and secure by tightening the set screws. Fingers should be snug and allow rotational movement of the workpiece. Lubricate the finger tips with an anti-seize grease during operation.
7. After prolonged use, the fingers will show wear. Either mill or file the tips for a new contact surface.

Follow Rest

The follow rest in **Figure 40** is mounted on the saddle and follows the movement of the tool. It can be attached/removed by two cap screws located at the base of the follow rest. The follow rest requires only two fingers as the cutting tool acts as the third. The follow rest is used on long, slender parts to prevent flexing of the workpiece from the pressure of the cutting tool.

The sliding fingers are set similar to those of the steady rest—free of play but not binding. Always lubricate during operation. Remove the follow rest from the saddle when not in use. After prolonged use, the fingers will need to be milled or filed to clean up the contact surface.



Figure 40. Follow rest attachment.



Setting Compound Slide

The compound slide is used to cut tapers on parts or to set the proper infeed angle when threading. It may also be used to cut specific lengths longitudinally, when set parallel to the spindle axis.

The compound slide handwheel has a graduated dial for precise inch feed increments. The base of the compound slide has a graduated scale for angular setup.

To set the angular position:

1. Loosen the two hex nuts, one on each side of the compound slide (see **Figure 41**).

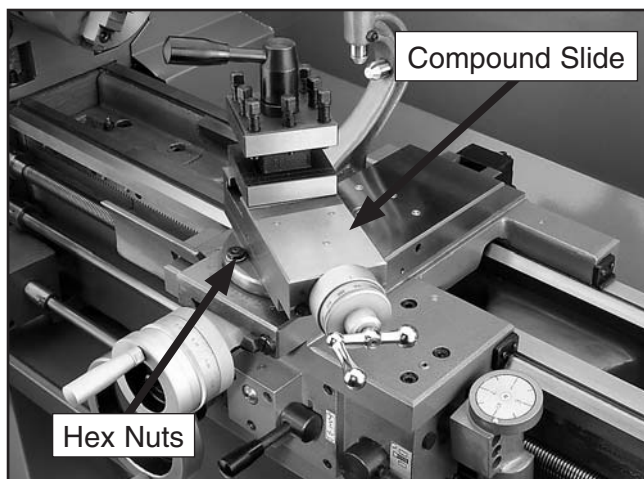

Figure 41. Compound slide set at an angle.

2. Rotate the compound slide to the desired angular position. Use the scale at the base of the slide and the indicator marks on the carriage to set the position.
3. Tighten the two hex nuts. Be sure to not over-tighten, as you may strip threads.

Four-Way Tool Post

The four-way tool post is mounted on top of the compound slide, and allows a maximum of four tools to be loaded simultaneously.

The four-way tool post allows for quick indexing to new tools. This is accomplished by rotating the top handle counterclockwise and then rotating the tool post to the desired position. Rotate the top handle clockwise to lock the tool into position.

To load the tool post:

1. Choose the desired cutting tool.
2. Loosen the tool post bolts so that the cutting tool can fit underneath the tool post bolts.
3. Use a minimum of two tool post bolts to hold down the cutting tool and tighten firmly (see **Figure 42**).

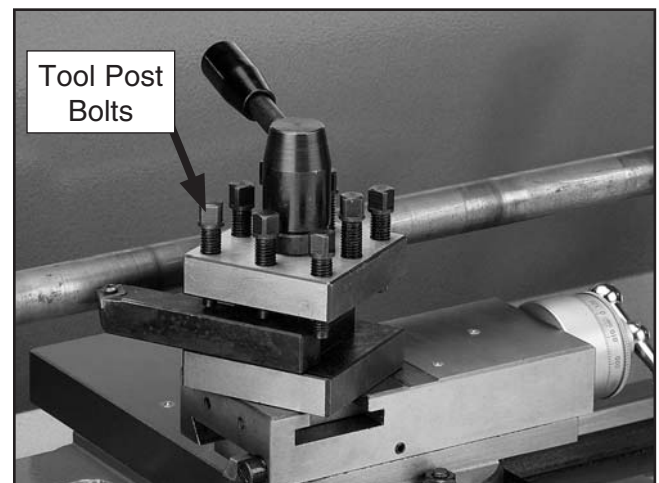

Figure 42. Tool post bolts.

4. Repeat **Steps 1–3** for the three remaining openings, as needed.



Gap Removal

The Model G4016 comes equipped with a gap section below the spindle that can be removed for turning large diameter parts or when using a large diameter faceplate.

The gap is installed, then ground, at the factory during lathe assembly for precise fit and alignment. Factors during the remaining assembly apply additional forces to the gap; therefore, replacing the gap to the original position will be very difficult. **If you choose to remove the gap, we don't recommend attempting to replace it.**

To remove the gap:

1. Find the two taper pin nuts located on the bed of the gap (see **Figure 43**).



Figure 43. Lathe gap.

2. Using an open-ended wrench, tighten the nut. This will cause the taper pin to release. Remove the taper pin and repeat for the second nut.
3. Remove the four cap screws and tap the outside of the gap with a dead blow hammer to loosen, and remove the gap section.

Setting RPM

!WARNING

Failure to follow RPM and feed rate guidelines may threaten operator safety by ejecting parts or breaking tools.

To determine the needed RPM:

1. Use the table in **Figure 44** to determine the cutting speed required for the material of your workpiece.

Cutting Speeds for High Speed Steel (HSS) Cutting Tools

Workpiece Material	Cutting Speed (sfm)
Aluminum & Alloys	300
Brass & Bronze	150
Copper	100
Cast Iron, soft	80
Cast Iron, hard	50
Mild Steel	90
Cast Steel	80
Alloy Steel, hard	40
Tool Steel	50
Stainless Steel	60
Titanium	50
Plastics	300-800
Wood	300-500

Note: For carbide cutting tools, double the cutting speed. These values are a guideline only. Refer to the *MACHINERY'S HANDBOOK* for more detailed information.

Figure 44. Cutting speed table.

2. Determine the final diameter, in inches, for the cut you are about to take.

Note: For this step you will need to average out the diameters or work with the finish diameter for your calculations.



- Use the following formula to determine the needed RPM for your operation:

$$\frac{\text{Cutting Speed} \times 4}{\text{Diameter of Cut}} = \text{RPM}$$

- With the calculated RPM, examine the spindle speed chart on the front of the headstock to find the closest match.

Note: *In most cases the calculated RPM will be between the available spindle RPMs. You will need to use your judgement about choosing a higher or lower spindle RPM.*

- Make sure the spindle is completely stopped before proceeding.
- Move the High/Low lever shown in **Figure 45** to the appropriate setting for the RPM that you are selecting.
- Move the speed selection lever to the desired RPM setting.

Note: *You may need to rotate the spindle by hand to get the levers to properly engage.*

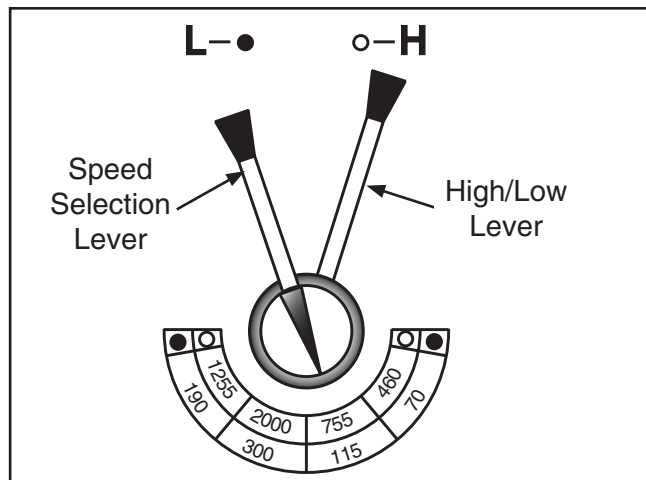

Figure 45. Spindle speed selectors.

Manual Feed

This sub-section will review the individual controls on the carriage and provide descriptions of their uses (see **Figure 46**).

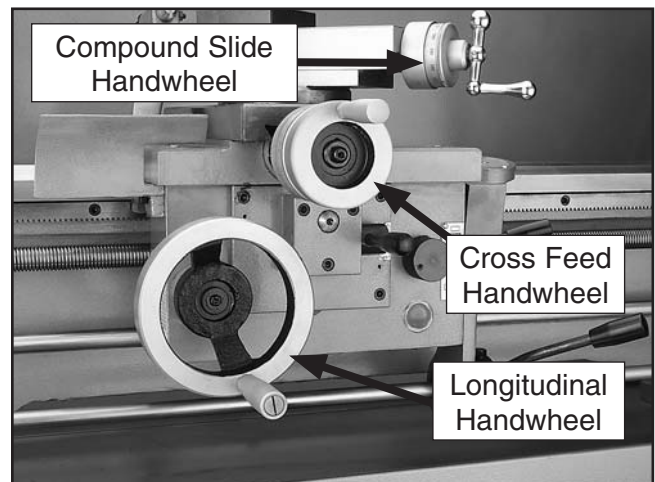

Figure 46. Carriage Controls.

Longitudinal Handwheel

The longitudinal handwheel moves the carriage left or right along the bed. This handwheel is used when setting up the machine or when manual control is desired during turning operations.

Cross Feed Handwheel

The cross feed handwheel moves the top slide toward and away from the work. Turning the dial clockwise moves the slide toward the workpiece.

Compound Slide Handwheel

The compound slide handwheel controls the position of the cutting tool relative to the workpiece. The compound slide is adjustable for any angle within its range. Angle adjustment is controlled by cap screws on the base of the compound slide.



Power Feed

NOTICE

Feed rate is based on spindle RPM. High feed rates combined with high spindle speeds result in a rapidly moving carriage or cross slide. Pay close attention to the feed rate you have chosen and keep your hand poised over the feed switch. Failure to fully understand this will cause the carriage to crash into the spindle.

The power feed operates the carriage and the cross slide. The carriage feeds right or left, and the cross slide can feed in or out.

To engage the power feed:

1. Turn the spindle **OFF** and allow it to completely stop before making gear changes.
2. Move the feed direction lever to the desired longitudinal feed setting indicated by the arrow above the screw thread. Cross feed directions are as follows: when the arrow points left, the cross feed is away from the spindle axis; when arrow points right, the cross feed is towards the spindle axis (see **Figure 47**).

Note: These instructions are valid with a counterclockwise rotation of the spindle. All directions reverse when spindle rotation is reversed.

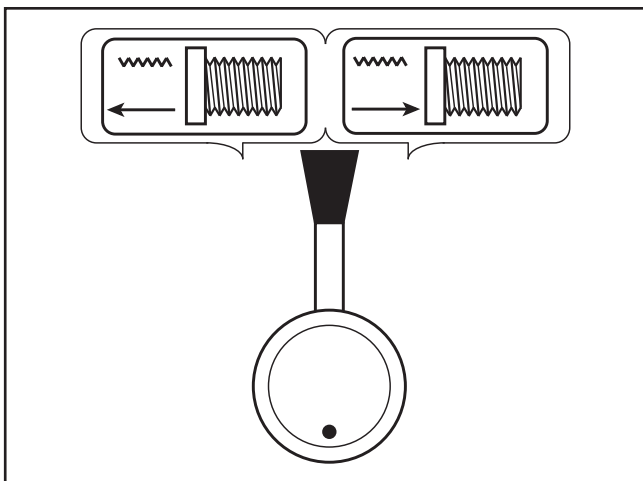

Figure 47. Feed direction selector.

3. Set the Feed Rod/Lead Screw selector shown in **Figure 48** to Feed Rod.

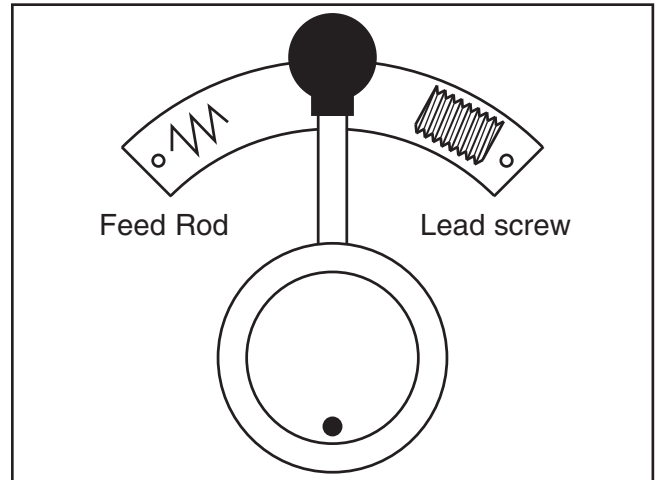

Figure 48. Feed Rod/Lead Screw Selector.

4. Push the power feed lever shown in **Figure 49** to the left and up to engage the cross feed. Pull the power feed lever to the right and down to engage the longitudinal feed.

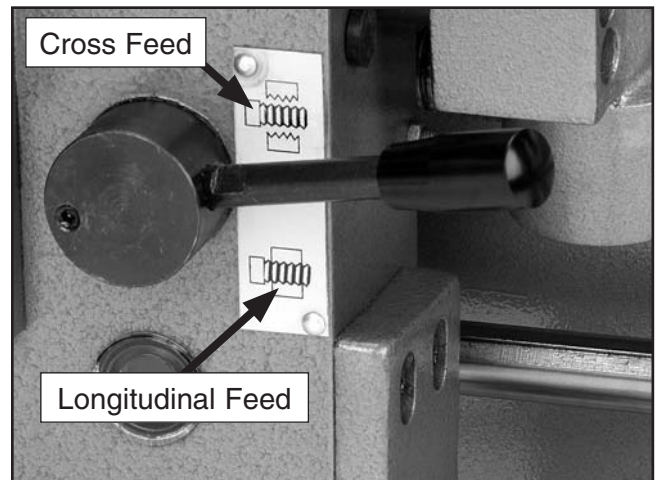

Figure 49. Cross/Longitudinal Feed Selector.

5. Return the lever to the center position to disengage the power feed.



Setting Feed Rate

Feed rate is determined by the machined material, the type of tooling used, and by the desired finish. Refer to the *Machinery's Handbook* for further information.

To set the feed rate:

1. Turn the spindle **OFF** and wait until it comes to a complete stop before making any gear changes.
2. Set the power feed as described on **Page 36**.
3. Use the feed rate chart (**Figure 51**) to determine the lever combination for the desired feed rate. The upper value in each cell of the feed rate chart is for the longitudinal feed. The lower value is for the cross feed.

Example: To set the lathe to the slowest cross feed rate of 0.0012" per inch, locate 0.0012 on the chart. The lever combination on the chart is E and 8.

4. Change the feed rate using the levers shown in **Figure 50**. The left lever is for letters, and the right is for numbers.

Note: You may have to rotate the spindle to allow the levers to engage in the desired hole.

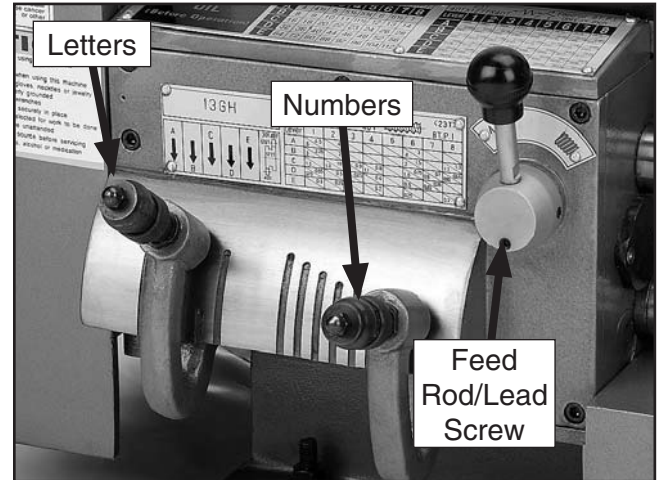

Figure 50. Feed rate control levers.

5. Pull the knob on the lever and rotate it down. Line up the lever with the desired character, rotate the lever up, and allow the pin to engage in the hole.

23T 40T x 127T x 40T					Feedrod 8 T.P.I. Unit = Inch			
LEVER	1	2	3	4	5	6	7	8
A	0.1005	0.0893	0.0804	0.0731	0.0699	0.067	0.0618	0.0574
	0.0345	0.0318	0.0276	0.0251	0.024	0.023	0.0213	0.0197
B	0.0502	0.0447	0.0402	0.0365	0.0349	0.0335	0.0309	0.0287
	0.0172	0.0154	0.0138	0.0126	0.012	0.0115	0.0106	0.0098
C	0.0251	0.0223	0.0201	0.0183	0.0175	0.0167	0.0155	0.0143
	0.0086	0.0077	0.0069	0.0063	0.006	0.0058	0.0053	0.0049
D	0.0126	0.0112	0.01	0.0091	0.0088	0.0084	0.0077	0.0072
	0.0043	0.0038	0.0035	0.0031	0.003	0.0029	0.0027	0.0025
E	0.0063	0.0056	0.005	0.0046	0.0044	0.0042	0.0039	0.0036
	0.0022	0.0019	0.0017	0.0016	0.0015	0.0014	0.0013	0.0012

Figure 51. Feed rate chart in inches per revolution.



Thread Settings

Changing gears for cutting metric threads will be explained in the next sub-section.

To set up for cutting threads:

1. Turn the spindle **OFF** and allow it to completely stop before making any changes.
2. Move the Feed Rod/Lead Screw selector to the lead screw position and move the feed direction selector to the desired thread direction (see **Figure 52**).

Note: Rotate the spindle by hand or move the apron if the gears do not engage.

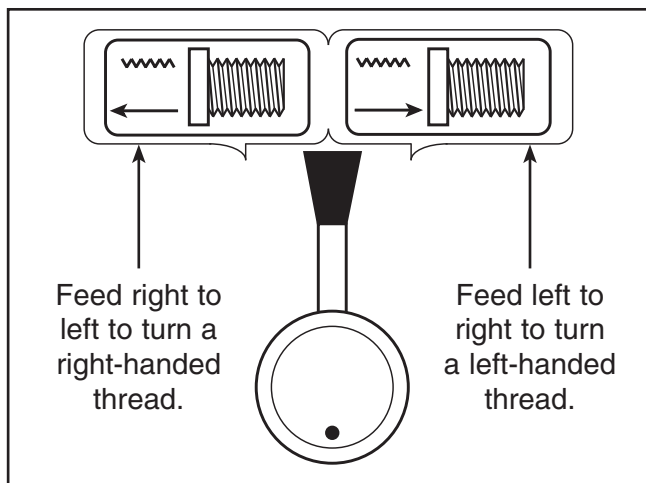

Figure 52. Left/right hand threads.

3. Find the desired TPI for inch threads from **Figure 53** or the desired metric thread pitch from **Figure 54**. Work to the left and up to determine the correct lever settings. These charts are also on the front of the head-stock.

Example: To cut 20 TPI thread, the handle combination would be C and 3.

4. Move the same levers used for feed rate to the appropriate letter/number setting by pulling the knob on the lever and rotating it down. Line up the lever with the desired character, rotate the lever up, and allow the pin to engage in the hole.

Note: Rotate the spindle by hand or move the apron if the gears do not engage.

40T x 127T x 40T		1"		(23T)		8 TPI		
LEVER	1	2	3	4	5	6	7	8
A	4	4½	5	5½	5¾	6	6½	7
B	8	9	10	11	11½	12	13	14
C	16	18	20	22	23	24	26	28
D	32	36	40	44	46	48	52	56
E	64	72	80	88	92	96	104	112

Figure 53. Inch thread chart.

$\frac{40T}{127T} \times \frac{120T}{40T}$		$\frac{30T}{127T} \times \frac{120T}{40T}$		mm		(23T)		8 TPI	
LEVER	1	2	3	4	5	6	7	8	
A	4.5	4				3			
B	2.25	2				1.5		1.3	
C	1.5	1.0	0.9	0.8		0.75	0.7	0.65	
D	0.55	0.5	0.45	0.4		0.35			
E	0.3	0.25	0.2			0.25		0.2	

Note: The thread pitch listed on the right of each cell corresponds to the gear combination at the top of the chart on the right. The pitch on the left of the cell corresponds to the combination on the left.

Figure 54. Metric thread chart.



Changing Gears for Metric Threads

The gears can be reconfigured to machine metric threads by installing a 30T gear or turning around the 40T gear that comes installed depending on the desired thread.

To change the gears:

1. **Disconnect the power to the lathe!**
2. Remove the end cover to expose the gears.
3. To set the gears in the 30T/127T X 120T/40T configuration, remove the hex nut and the slot head screw (Items A and C shown in **Figure 55**).
 - Loosen the hex nuts, Items G & E, and the cap screw, Item F, shown in **Figure 55** and drop the large gear set out of its mesh.
 - Remove the 40T gear, Item B in **Figure 55**, and replace it with the 30T gear.
 - Remove the 40T gear, Item D, turn it around, and put it back on the shaft.

4. To set the gears in the 40T/127T X 120T/40T configuration, remove the slot head screw shown in **Figure 55**, Item C.
 - Loosen hex nuts, Items G & E, and the cap screw, Item F, shown in **Figure 55** and drop the large gear set out of its mesh.
 - Remove the 40T gear, Item D, turn it around, and put it back on the shaft.
5. Replace the fasteners that hold the gears in place. **DO NOT** overtighten. Overtightening will make them difficult to remove.
6. Move the large gears until they mesh with the smaller gears. Make sure there is a backlash of 0.002"-0.003" between gears and tighten the cap screw and hex nut to hold the gears in place.

Note: *Setting the gears too tight will cause excessive wear and noise, setting the gears too loose may cause slippage and possibly break gear teeth.*

7. Close the end cover door and connect the power.

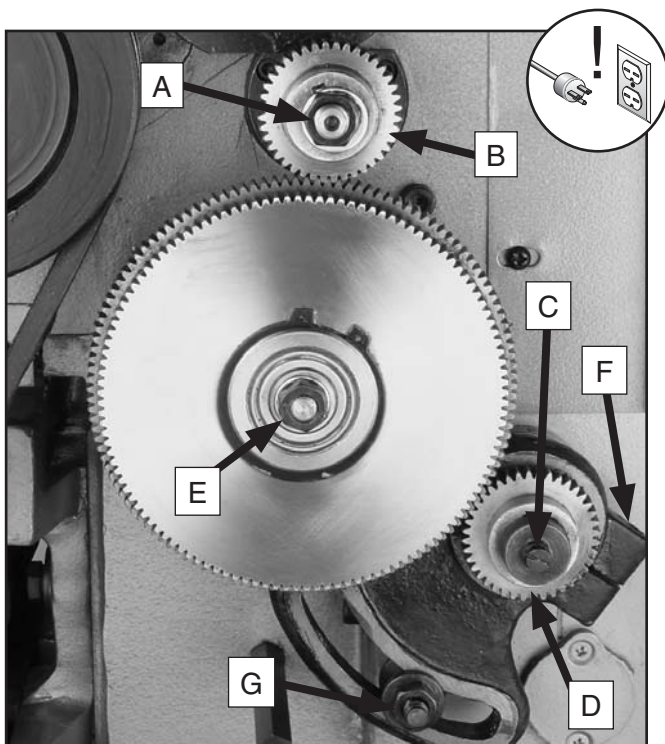

Figure 55. Gear change locations.



Threading Operation

To cut threads:

1. Set the compound rest to the appropriate angle for the thread you want to cut. For a Unified National Series (UNF) thread, this is 29° off of vertical to the spindle axis.
2. If the thread dial (**Figure 56**) is not engaged with the lead screw, use a hex wrench to loosen the thread dial and rotate it to engage the lead screw, then tighten the dial.

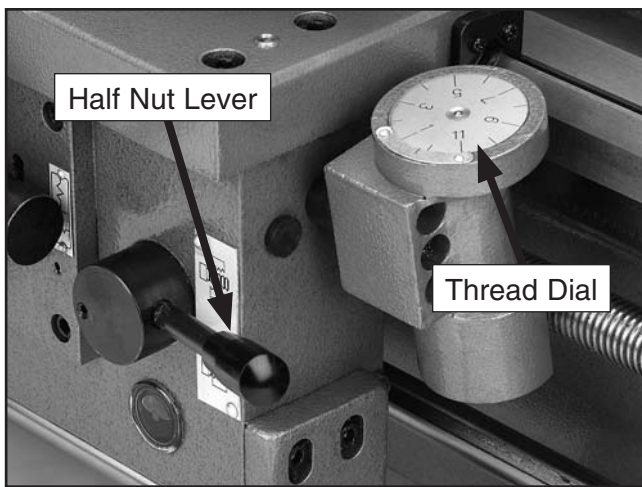

Figure 56. Half nut and thread dial locations.

3. Select the RPM you want to use. A slower RPM will give you more time to react, especially if threading over a short distance or threading up to a shoulder.
4. Examine the thread charts (inch or metric) and set the feed rate selectors as explained on **Page 38**.
5. Turn **ON** the spindle to verify settings. Check to see that the lead screw is turning and verify that the carriage moves in the correct direction by engaging the half nut lever shown in **Figure 56**.

CAUTION

DO NOT engage the half nut when spindle is operating over 200 RPM. Disregarding this warning may cause damage to the leadscrew and bearings.

6. Once you are confident the settings are correct, disengage the half nut and turn **OFF** the spindle.
7. Examine the thread dial (**Figure 57**) to determine which numbers on the thread dial will engage the half nut.

Note: To maintain accuracy and consistency, engage the half nut on the same mark on each pass. Failure to start on the same number each time may lead to cutting off the thread made in the previous pass.

Indicator Scale			
TPI	Scale	TPI	Scale
4	1 - 4	24	1 - 8
4½	1	26	1 or 3
5	1	28	1 - 4
5½	1	32	1 - 8
6	1 or 3	36	1 - 4
6½	1	38	1 or 3
7	1	40	1 - 8
8	1 - 8	44	1 - 4
9	1	46	1 or 3
9½	1	48	1 - 8
10	1 or 3	52	1 - 4
11	1	56	1 - 8
11½	1	64	1 - 8
12	1 - 4	72	1 - 8
13	1	76	1 - 4
14	1 or 3	80	1 - 8
16	1 - 8	88	1 - 8
18	1 or 3	92	1 - 4
19	1	96	1 - 8
20	1 - 4	104	1 - 8
22	1 or 3	112	1 - 8
23	1		

Figure 57. Thread dial chart.

8. The thread dial is unnecessary for cutting metric threads. Leave the half nut engaged until the threads are complete.
9. Set the tool tip perpendicular to the workpiece, center it vertically, and line up the tool for the initial cut.
10. Turn **ON** the spindle and engage the half nut according to the thread dial to cut your threads.



SECTION 5: ACCESSORIES

This section includes the most common accessories available for this lathe through the Grizzly catalog, online at www.grizzly.com, or by calling 1-800-523-4777.

G7895—Citrus Degreaser

This citrus based degreaser is perfect for cleaning cosmolene off of new equipment. It also works for cleaning auto parts, tools, concrete, and porcelain surfaces. Natural, safe for the environment, and contains no CFC's.



Figure 58. G7895 Citrus Degreaser.

G7984—Face Shield

H1298—Dust Sealed Safety Glasses

H1300—UV Blocking, Clear Safety Glasses

H2347—Uvex® Spitfire Safety Glasses

H0736—Shop Fox® Safety Glasses

Safety Glasses are essential to every shop. If you already have a pair, buy extras for visitors or employees. You can't be too careful when it comes to shop safety!



Figure 59. Our most popular safety glasses.

G2871—Boeshield® T-9 12 oz Spray

G2870—Boeshield® T-9 4 oz Spray

This ozone friendly protective spray penetrates deep and really holds up against corrosive environments. Lubricates metals for months and is safe for use on most paints, plastics, and vinyls.



Figure 60. Boeshield® T-9 spray.

H3788—G96® Gun Treatment 12 oz Spray

H3789—G96® Gun Treatment 4.5 oz Spray

This triple action gun treatment cleans, lubricates and protects all metal parts. Contains solvents that completely remove all traces of rust and corrosion and leaves no gummy residue.



Figure 61. G96® Gun Treatment spray.

Call 1-800-523-4777 To Order



G4034—Quick Change Collet Closer

This Quick Change Collet Closer allows you to quickly interchange parts on your Model G4016 Metal-Cutting Lathe. The positive-locking handle clamps standard 5-C collets safely and securely for precision turning.

See the current Grizzly catalog for a full line of 5-C collets.

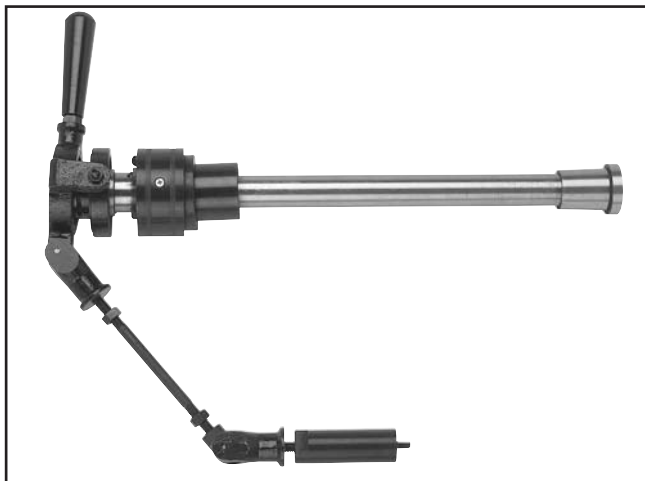

Figure 62. G4034 Quick Change Collet Closer.

H0775—Taper Attachment for the G4016 Lathe.

The Model H0775 mounts to the back of the carriage and bed way to produce accurate tapers up to 12" without repositioning. It features inch-per-foot and degree scales at both ends and a fine thread screw for exacting control when adjusting taper angles.

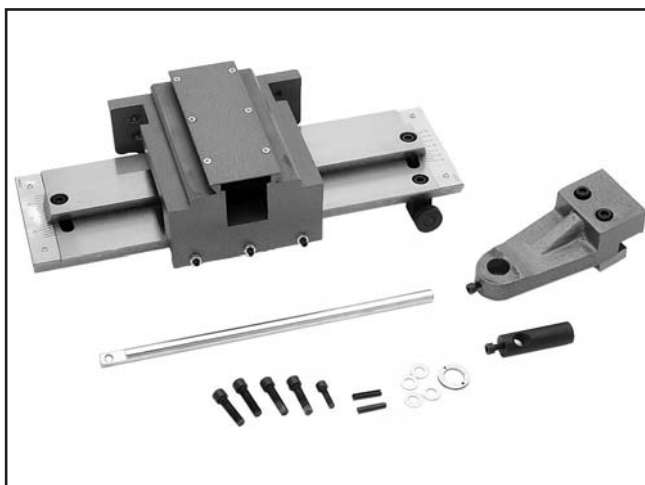

Figure 63. H0775 Taper Attachment.

G9256—6" Dial Caliper

G9257—8" Dial Caliper

G9258—12" Dial Caliper

These traditional dial calipers are accurate to 0.001" and can measure outside surfaces, inside surfaces, and heights/depths. Features stainless steel, shock resistant construction and a dust proof display. An absolute treat for the perfectionist!

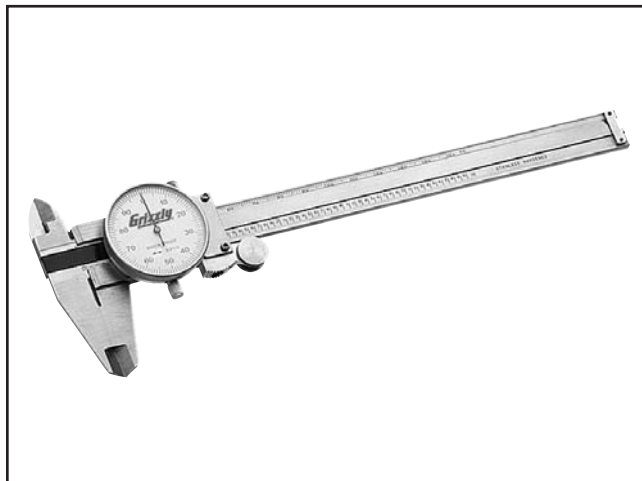

Figure 64. Grizzly® Dial Calipers.

H3022—Measurement Tool Set

Includes magnetic base, 1" dial indicator (.001"), and 6" dial caliper (.001"). The extremely low price has made this a very popular seller!



Figure 65. H3022 Measurement Tool Set.

Call 1-800-523-4777 To Order



H2670—HSS Square Tool Bits ½" x ½" x 4

Our ground tool bits are M-2 HSS, making them some of the most durable tool bits around. Make your own specialized cutters in any shape using a silicon carbide grinding wheel (G8235-37) on your grinder.

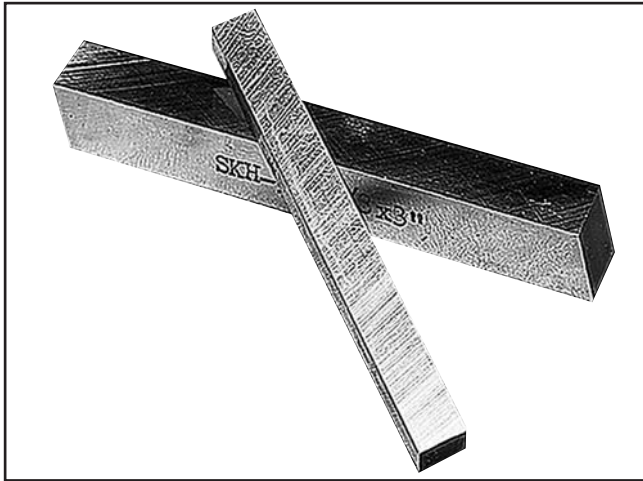

Figure 66. H2670 HSS Square Tool Bits.

H5687—8-Pc. Pre-Ground Tool Bit Set

Tired of grinding your blank high speed steel tool bits? We've done it for you! 8-pc set comes with these sharpened profiles: offset right and left hand tools with chip breaker, straight and chip breaker style threading tools, internal threading tool, parting tool, boring tool and turning tool. These tool bits are evenly hardened to better than 64C.

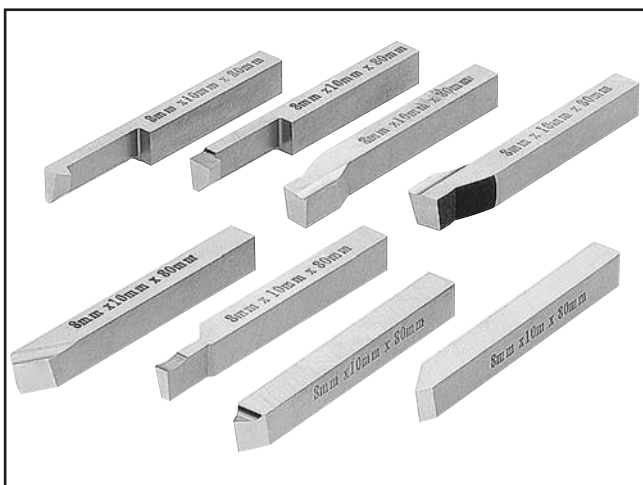

Figure 67. H5687 Pre-Ground Tool Bit Set.

G9777—20-Pc. Carbide Tipped Tool Bit Set

An exceptional value for carbide lathe tool bits! This twenty-piece set offers tremendous savings over bits sold individually, plus every type is duplicated and ready at hand when you need it. The carbide is C-6 grade for cutting steel and alloys.

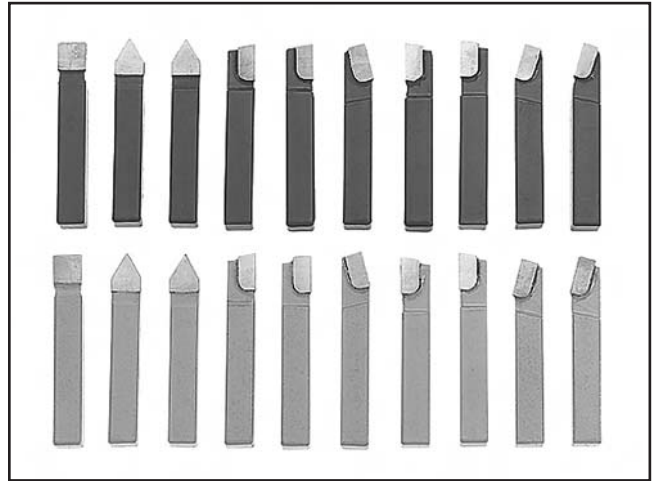

Figure 68. G9777 20 Pc. Carbide Tool Set.

G5640—5-Pc. Indexable Carbide Tool Set ½"

G6706—Replacement TiN Coated Carbide Indexable Insert

Five-piece turning tool set features indexable carbide inserts with "spline" type hold-down screw that allow indexing without removing the screw. Each set includes AR, AL, BR, BL, and E style tools with carbide inserts, hex wrench, extra hold-down screws and a wooden case.



Figure 69. G5640 5 Pc. Indexable Tool Set.



H2972—Cut Off Holder with Blade

H4268— $\frac{3}{32}$ " x $\frac{5}{8}$ " x 5" Replacement Blade

Small enough to fit most 4-way turret tool posts, but rugged enough to handle the job, this cut-off tool holder is a must. Comes with a wrench and cut-off tool bit. Uses $\frac{3}{32}$ " x $\frac{5}{8}$ " x 5" tool bits. Shank measures $\frac{1}{2}$ " x $\frac{1}{4}$ " x 3".



Figure 70. H2972 Cut Off Holder with Blade.

H2996—Double Ended Boring Bar

This is a well made boring bar and holder. The boring bar holds the tool bit at 90° at one end and 45° at the other. Comes with a wrench and tool bit. Bar size is $\frac{3}{8}$ " x 4 $\frac{1}{2}$ ", holder is 2 $\frac{1}{4}$ " x $\frac{1}{2}$ ", uses $\frac{1}{8}$ " tool bits.

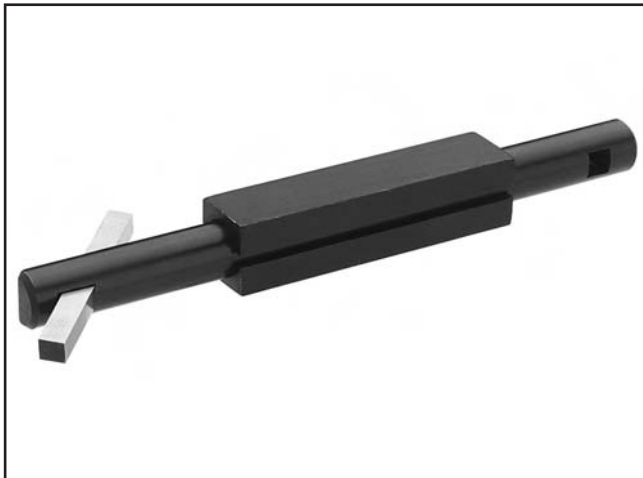

Figure 71. H2996 Double Ended Boring Bar.

H5936—2 Pc. Knurling Tool Set

This 2 piece set includes a $\frac{1}{2}$ " x 4" Single Knurling Toolholder and a $\frac{1}{2}$ " x 4 $\frac{1}{2}$ " Double Knurling Toolholder with Pivoting Head. Both have a black oxide finish.



Figure 72. H5936 2 Pc. Knurling Tool Set.

H2987— $\frac{1}{2}$ " Bent Lathe Dog

H2988—1" Bent Lathe Dog

H2989—1 $\frac{1}{2}$ " Bent Lathe Dog

H2990—2" Bent Lathe Dog

H2991—3" Bent Lathe Dog

Just the thing for precision machining between centers! These bent tail Lathe Dogs are made of durable cast iron and feature square head bolts.



Figure 73. H2987-91 Lathe Dogs.



MODEL	SIZE	BODY DIA.	DRILL DIA.	OVERALL LENGTH
H4456	1	1/8"	3/64"	1 1/4"
H4457	2	3/16"	5/64"	1 7/8"
H4458	3	1/4"	7/64"	2"
H4459	4	5/16"	1/8"	2 1/8"
H4460	5	7/16"	3/16"	2 3/4"
H4461	6	1/2"	7/32"	3"
H4462	7	5/8"	1/4"	3 1/4"
H4463	8	3/4"	5/16"	3 1/2"

These High Speed Steel Center Drills are precision ground for unsurpassed accuracy.



Figure 74. H4456-63 HSS Ground Center Drills.

G1070—MT3 Live Center Set

A super blend of quality and convenience, this live center set offers seven interchangeable tips. High-quality needle bearings prolong tool life and special tool steel body and tips are precision ground. Supplied in wooden box.



Figure 75. G1070 Live Center Set.

G5690—12" to 14" Swing Quick Change Tool Post Set

Speed up your lathe operations and enjoy the convenience of easy tool set-up with this Quick Change Tool Post Set. Tool posts feature piston type mechanism and come with five tool holders including: turning holder, knurling/turning holder, parting tool holder, boring bar holder and boring/turning holder. All milled surfaces are hardened and precision ground for repeatable accuracy. Each set comes with a blank T-nut which requires machining to fit your lathe.

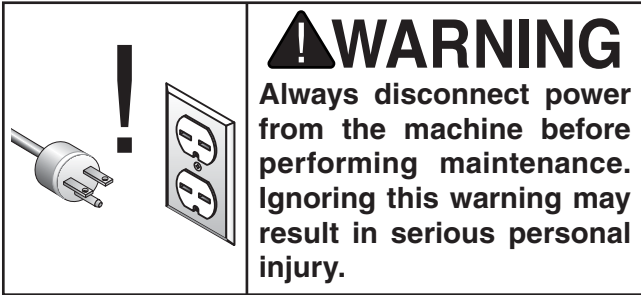

Figure 76. G5690 Quick Change Tool Post Set.

Call 1-800-523-4777 To Order



SECTION 6: MAINTENANCE



Schedule

For optimum performance from your machine, follow this maintenance schedule and refer to any specific instructions given in this section.

Daily Check:

- Loose mounting bolts.
- Worn switch or safety features.
- Worn or damaged cords and plugs.
- Damaged V-belt.
- Any other unsafe condition.

Every 6–8 Hours of Running Time:

- Lubricate all ball fittings.
- Clean and wipe down lathe.

Yearly:

- Replace headstock and apron gear oil.
- Inspect V-Belt and replace if needed.

Cleaning

Cleaning the Model G4016 is relatively easy. Disconnect the lathe before cleaning it. Remove chips as they accumulate. Vacuum excess metal chips and wipe off the remaining coolant with a dry cloth when finished for the day. Chips left on the machine soaked with water based coolant will invite oxidation and gummy residue to build up around moving parts. Preventative measures like this will help keep your lathe running smoothly. Always be safe and responsible with the use and disposal of cleaning products.

Unpainted Cast Iron

Protect the unpainted cast iron surfaces on the lathe by wiping them clean after every use—this ensures moisture does not remain on bare metal surfaces.

Keep ways rust-free with regular applications of products like G96® Gun Treatment, or Boeshield® T-9 (see **SECTION 5: ACCESSORIES** on Page 41 for more details).

Lubrication

NOTICE

Failure to follow lubrication guidelines will lead to rapid deterioration of lathe components.

The headstock and apron use SAE 20W/ISO 68 non-detergent gear oil or equivalent lubricant. Keep the oil level at the indicator mark in the headstock and apron sight glasses (**Figures 77 & 78**). After three months of use, drain the oil and refill. After the initial oil change, change the headstock oil on an annual basis or more frequently if machine is used daily.

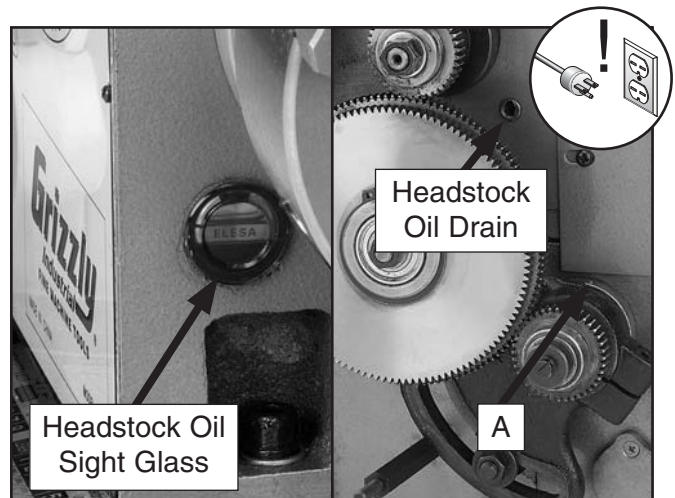

Figure 77. Headstock oil sight and drain.



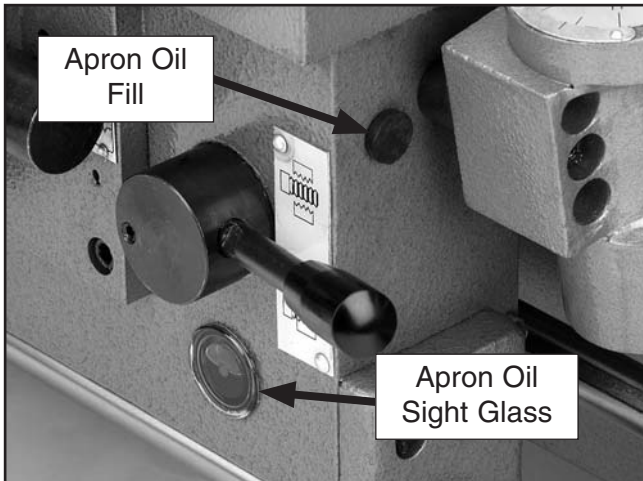

Figure 78. Apron oil sight and oil fill location.

Ball fittings are responsible for the majority of the machine lubrication. To lubricate ball fittings, clean the outside of the ball fitting, depress the ball with the tip of the oil can nozzle and squirt one to two shots of SAE 20W non-detergent oil or equivalent inside the fitting. Some areas may require fewer or more shots depending on use.

Lubricate the following areas every day:

- A. Gearbox Input Shaft:** Remove the end access panel and oil the gearbox input shaft (see **Figure 77**).
- B. Quick Change Gearbox:** Remove the gearbox cover plate as shown in **Figure 79** and oil each recessed hole (five to six drops).



Figure 79. Quick change gearbox cover.

- C. Saddle:** Lubricate two oil ports on apron top (see **Figure 80**).

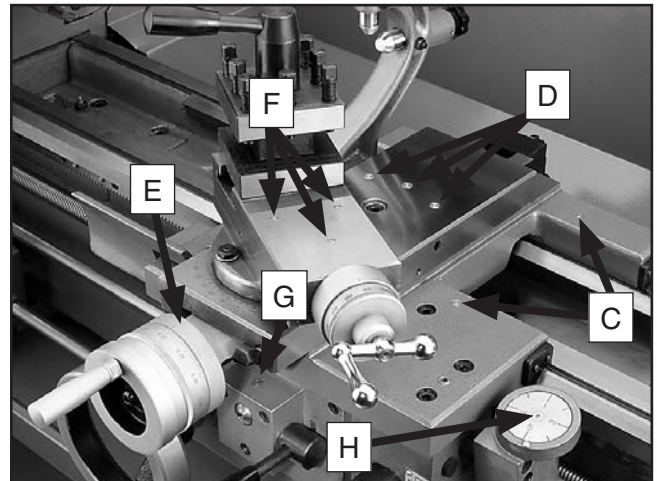

Figure 80. Carriage ball fittings.

- D. Cross Slide:** Lubricate three oil ports (see **Figure 80**).
- E. Cross Slide Handle:** Lubricate one oil port (see **Figure 80**).
- F. Compound Rest:** Lubricate three oil ports (see **Figure 80**).
- G. Apron:** Lubricate two oil ports. One of the ports is on top of the longitudinal handwheel (see **Figure 80**).
- H. Thread Dial Indicator:** Lubricate one oil port (see **Figure 80**).
- I. Tailstock:** Lubricate three oil ports (see **Figure 81**).

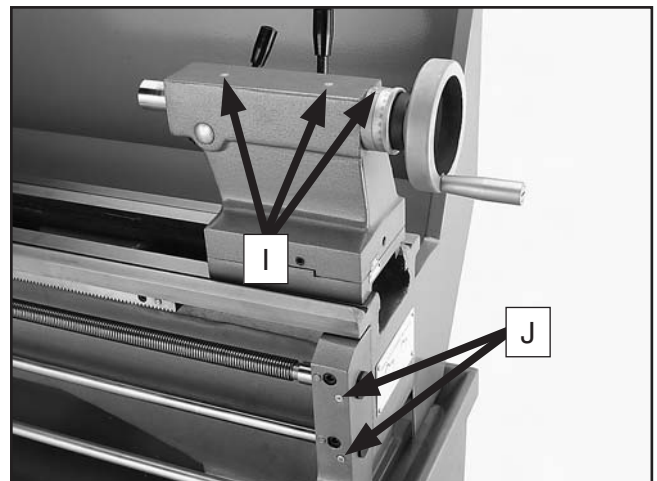

Figure 81. Tailstock ball fittings.

- J. Lead Screw and Feed Rod:** Lubricate two oil ports (see **Figure 81**).

Coat the chuck scroll and chuck jaw scroll teeth with #2 lithium grease. Apply a light film of 20W oil to the spindle camlocks and chuck body. **DO NOT** apply any lubrication to the clamping surfaces.



SECTION 7: SERVICE

About Service

This section is provided for your convenience—it is not a substitute for the Grizzly Service Department. If you need help troubleshooting, you need replacement parts, or you are unsure of how to perform the procedures in this section, then feel free to call our Technical Support at (570) 546-9663.

Troubleshooting

Operation and Work Results



SYMPTOM:	POSSIBLE CAUSE:	CORRECTIVE ACTION:
Machine does not start or a breaker trips.	<ol style="list-style-type: none"> Emergency stop push-button is engaged, or is faulty. Plug or receptacle is at fault or wired incorrectly. Start capacitor is faulty. Contactors not getting energized or has burnt contacts. Wall fuse or circuit breaker is blown or tripped. Motor connection is wired incorrectly. Power supply is faulty, or is switched OFF. Motor ON button or ON/OFF switch is faulty. Centrifugal switch is at fault. Spindle rotation switch at fault. Cable or wiring is open or has high resistance. Motor is at fault. 	<ol style="list-style-type: none"> Rotate the emergency stop push button clockwise until it pops out, or replace faulty emergency switch. Test power plug and receptacle for good contact and correct wiring. Test capacitor and replace if necessary. Test for power in and out on all legs, and contactor operation. Replace unit if faulty. Make sure circuit breaker/fuse is sized correctly for machine load (refer to Page 12), or replace weak breaker. Correct motor wiring (see Page 54). Make sure all hot lines and grounds are operational and have correct voltage on all legs. Replace faulty ON button or ON/OFF switch. Adjust or replace the centrifugal switch. Turn switch to FWD or REV, or replace bad switch. Troubleshoot wires for internal or external breaks, check for disconnected or corroded connections and repair or replace wiring. Test motor and repair or replace.
Machine has vibration or noisy operation.	<ol style="list-style-type: none"> Motor or component is loose. Belts are slapping belt cover. V-belt is worn or is loose. Motor fan is rubbing on fan cover. 	<ol style="list-style-type: none"> Inspect, replace for stripped or damaged bolts/nuts, and re-tighten with thread locking fluid. Replace/realign belts with a new matched set, and re-tension belts (refer to Page 53). Inspect belt, replace and/or re-tension (refer to Page 53). Replace dented fan cover, and replace loose or damaged fan.



SYMPTOM:	POSSIBLE CAUSE:	CORRECTIVE ACTION:
	<ul style="list-style-type: none"> 5. Pulley is loose. 6. Machine is incorrectly mounted to the floor. 7. Bit is chattering. 8. Workpiece or chuck is at fault. 9. Motor bearings are at fault. 10. Gearbox is at fault. 	<ul style="list-style-type: none"> 5. Remove pulley, replace shaft, pulley, set-screw, and key as required, and realign. 6. Machine has loose anchor studs in floor, or is sitting on uneven floor. Replace/tighten/relocate as required. 7. Replace or resharpen bit, index bit to workpiece, use appropriate feed rate and cutting RPM. 8. Re-center workpiece in chuck or face plate, replace defective chuck. 9. Check bearings, replace motor or bearings if necessary. 10. Rebuild gearbox for bad gear(s)/bearing(s).
Machine stalls or is under-powered.	<ul style="list-style-type: none"> 1. Wrong workpiece material. 2. Workpiece alignment is at fault. 3. Incorrect spindle speed for task. 4. Gearbox is at fault. 5. Low power supply voltage. 6. Run capacitor is faulty. 7. Belt is slipping. 8. Plug or receptacle is at fault. 9. Motor connection is wired incorrectly. 10. Motor bearings are at fault. 11. Machine is undersized for the task. 12. Motor has overheated. 13. Spindle rotation switch at fault. 14. Motor is at fault. 15. Centrifugal switch is at fault. 	<ul style="list-style-type: none"> 1. Only process metal that has the correct properties for your type of machining. 2. Eliminate workpiece binding, use jig, fence, guide, clamps, roller table, or push blocks as required for workpiece alignment control. 3. Decrease spindle speed (see Page 34). 4. Select appropriate gear ratio, or replace broken or slipping gears. 5. Make sure all hot lines and grounds are operational and have correct voltage on all legs. 6. Test capacitor and replace if necessary. 7. Check belts and re-tension. Replace belts if necessary, align pulleys, and re-tension (refer to Page 53). 8. Test power plug and receptacle for good contact and correct wiring. 9. Correct motor wiring (see Page 54). 10. Rotate motor shaft to check for noisy or burnt bearings, repair/replace as required. 11. Use sharp lathe bits and chisels at the correct angle, reduce the feed rate/depth of cut, and use cutting fluid if possible. 12. Unobstruct motor cooling air flow, let motor cool, and reduce workload on machine. 13. Turn switch to FWD or REV, or replace bad switch. 14. Test motor and repair or replace if necessary. 15. Adjust or replace the centrifugal switch.
Bad surface finish.	<ul style="list-style-type: none"> 1. Wrong RPM or feed rate. 2. Dull tooling or poor tool selection. 3. Too much play in gibs. 4. Tool too high. 	<ul style="list-style-type: none"> 1. Adjust for appropriate RPM and feed rate (see Page 34). 2. Sharpen tooling or select a better tool for the intended operation. 3. Tighten gibs (refer to Page 52). 4. Lower the tool position.



SYMPTOM:	POSSIBLE CAUSE:	CORRECTIVE ACTION:
Can't remove tapered tool from tailstock quill.	<ol style="list-style-type: none"> 1. Quill had not retracted all the way back into the tailstock. 2. Debris was not removed from taper before inserting into quill. 	<ol style="list-style-type: none"> 1. Turn the quill handwheel until it forces taper out of quill. 2. Always make sure that taper surfaces are clean.
Cross slide, compound slide, or carriage feed has sloppy operation.	<ol style="list-style-type: none"> 1. Gibs are out of adjustment. 2. Handwheel is loose. 3. Lead screw mechanism worn or out of adjustment. 	<ol style="list-style-type: none"> 1. Tighten gib screw(s) (see Page 52). 2. Tighten handwheel fasteners. 3. Tighten any loose fasteners on lead screw mechanism.
Cross slide, compound slide, or carriage feed handwheel is hard to move.	<ol style="list-style-type: none"> 1. Gibs are loaded up with shavings, dust, or grime. 2. Gib screws are too tight. 3. Backlash setting too tight (cross slide only). 4. Bedways are dry. 	<ol style="list-style-type: none"> 1. Remove gibs, clean ways/dovetails, lubricate, and readjust gibs. 2. Loosen gib screw(s) slightly, and lubricate bedways (see Page 52). 3. Slightly loosen backlash setting by loosening the locking screw and adjusting the spanner ring at the end of the handle (see Page 51). 4. Lubricate bedways and handles.
Cutting tool or machine components vibrate excessively during cutting.	<ol style="list-style-type: none"> 1. Tool holder not tight enough. 2. Cutting tool sticks too far out of tool holder; lack of support. 3. Gibs are out of adjustment. 4. Dull cutting tool. 5. Incorrect spindle speed or feed rate. 	<ol style="list-style-type: none"> 1. Check for debris, clean, and retighten. 2. Reinstall cutting tool so no more than 1/3 of the total length is sticking out of the tool holder. 3. Tighten gib screws (see Page 52) at affected component. 4. Replace or resharpen cutting tool. 5. Use the recommended spindle speed (see Page 34).
Inaccurate turning results from one end of the workpiece to the other.	<ol style="list-style-type: none"> 1. Headstock and tailstock are not properly aligned with each other. 	<ol style="list-style-type: none"> 1. Realign the tailstock to the headstock spindle bore center line (see Page 30).
Chuck jaws won't move or don't move easily.	<ol style="list-style-type: none"> 1. Chips lodged in the jaws. 	<ol style="list-style-type: none"> 1. Remove jaws, clean and lubricate chuck threads, and replace jaws.
Carriage won't feed.	<ol style="list-style-type: none"> 1. Gears are not all engaged. 2. Gears are broken. 3. Loose screw on the feed handle. 	<ol style="list-style-type: none"> 1. Adjust gear positions. 2. Replace. 3. Tighten.



Cross Feed Backlash

Backlash is the amount of play in a lead screw. It is felt when turning a handwheel in one direction, then turning it in the other direction. Backlash is removed when the cross slide begins to move.

Note: When adjusting backlash, keep in mind the goal is to tighten the leadscrew without causing it to bind. Backlash can be compensated for, but overtightening will cause excessive wear to the sliding block and lead screw.

To adjust the backlash:

1. Feed the cross slide toward the operator until it reaches the end of its travel.
2. Remove the cap screw that secures the cross slide leadscrew nut (see **Figure 82**).



Figure 82. Cap screw securing the leadscrew.

3. Rotate the cross slide handle to feed the leadscrew nut out from under the cross slide as shown in **Figure 83**.

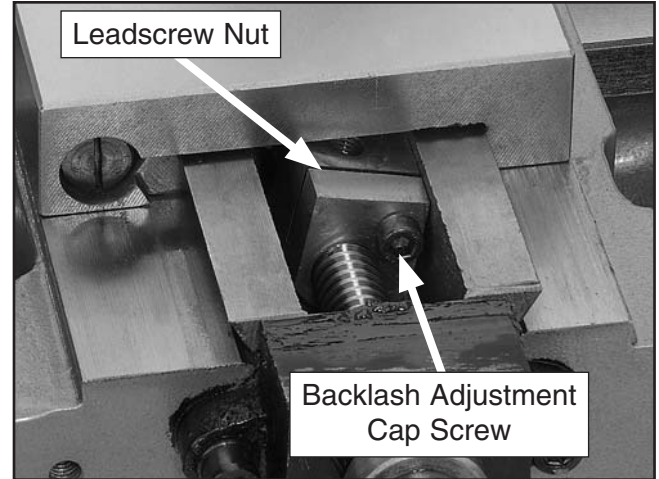

Figure 83. Leadscrew nut.

4. Tighten the backlash adjustment cap screw shown in **Figure 83** in small increments.
5. Test after each adjustment until the backlash amount is acceptable.
6. Feed the leadscrew nut back under the cross slide and replace the cap screw removed in **Step 1**.



Gibs

The saddle, cross feed, compound rest, and tailstock lock gibs can all be adjusted on the Model G4016 lathe.

Note: When adjusting gibs, keep in mind that the goal of gib adjustment is to remove sloppiness without causing the slides to bind. Loose gibs may cause poor finishes on the workpiece and may cause undue wear on the slide. Over-tightening may cause premature wear on the slide, lead screw, and nut.

Note: Make sure all areas are free of chips before adjusting.

To adjust the saddle gib:

1. Hold the set screws with a hex wrench and then loosen the four hex nuts found at the bottom rear of the cross slide. Back each hex nut off one full turn (see **Figure 84**).

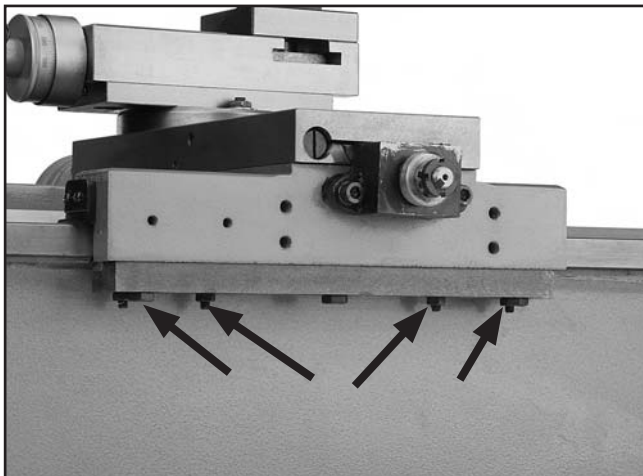

Figure 84. Saddle gib adjustments.

2. Turn the set screws with a hex wrench until a slight resistance is felt. DO NOT overtighten.
3. Move the carriage with the handwheel to feel the current drag. Adjust the set screws until the desired drag is achieved.

Note: Overtightening will cause excessive premature wear on the gibs.

4. Hold the set screws in place and tighten the hex nuts.

To adjust the cross slide gib:

1. Loosen the rear gib screw approximately one turn (see **Figure 85**).

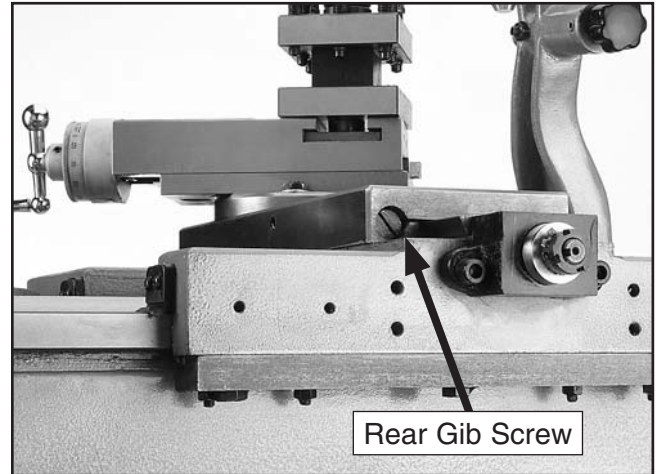

Figure 85. Rear cross feed gib screw.

2. Tighten the front gib screw a quarter turn (see **Figure 86**).

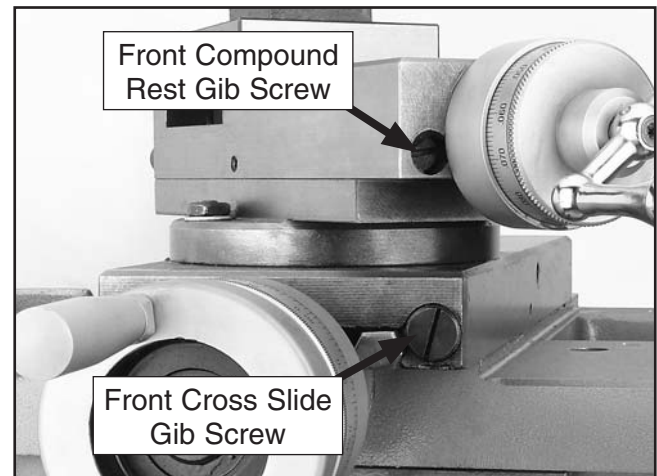

Figure 86. Front cross feed gib screw.

3. Turn the cross feed handwheel to feel the current drag and adjust the front screw until the desired drag is achieved.

To adjust the compound rest gib:

1. Loosen the rear gib screw approximately one turn.
2. Tighten the front gib screw a quarter turn.
3. Turn the cross feed handwheel to feel the current drag and adjust the front screw until the desired drag is achieved.



To adjust the tailstock lock:

1. Move the tailstock lock handle to the unlocked position.
2. Slide the tailstock to an area that will allow access to the hex nut under the tailstock block.
3. Tighten the tailstock hex nut $\frac{1}{4}$ turn at a time until the tailstock will not move when pushed by hand. Repeat as necessary (see **Figure 87**).

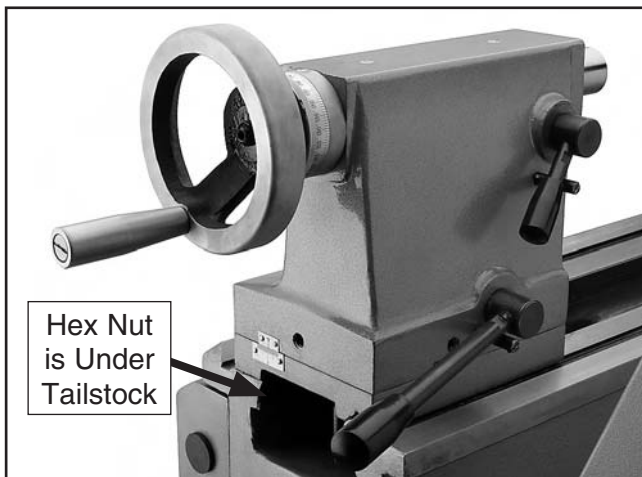

Figure 87. Tailstock nut and gib adjustment.

Replacing and Tightening V-Belt

To replace the V-belts on the lathe:

1. **Disconnect the power to the lathe!**
2. Remove the backsplash from the back of the lathe.
3. Remove the end cover on the headstock and the pulley cover.
4. Remove the tension off the old V-belts by loosening the motor mount nuts (**Figure 88**) and sliding the motor up.
5. Remove the old belts and install the new ones. Always replace these belts in pairs.
6. Pull down on the motor and tighten the motor mount bolts.
7. Test the V-belt tension by applying approximately 8 lbs. of force to the belts. When correctly tensioned this will cause approximately $\frac{3}{4}$ " of deflection.
8. Replace the pulley cover, the end cover, and the backsplash. Then reconnect the machine to its power source.

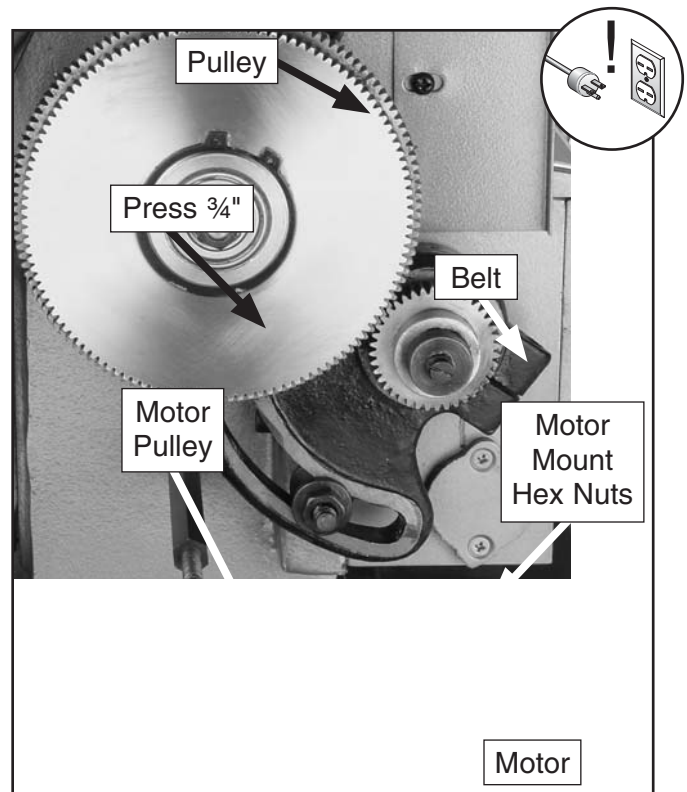
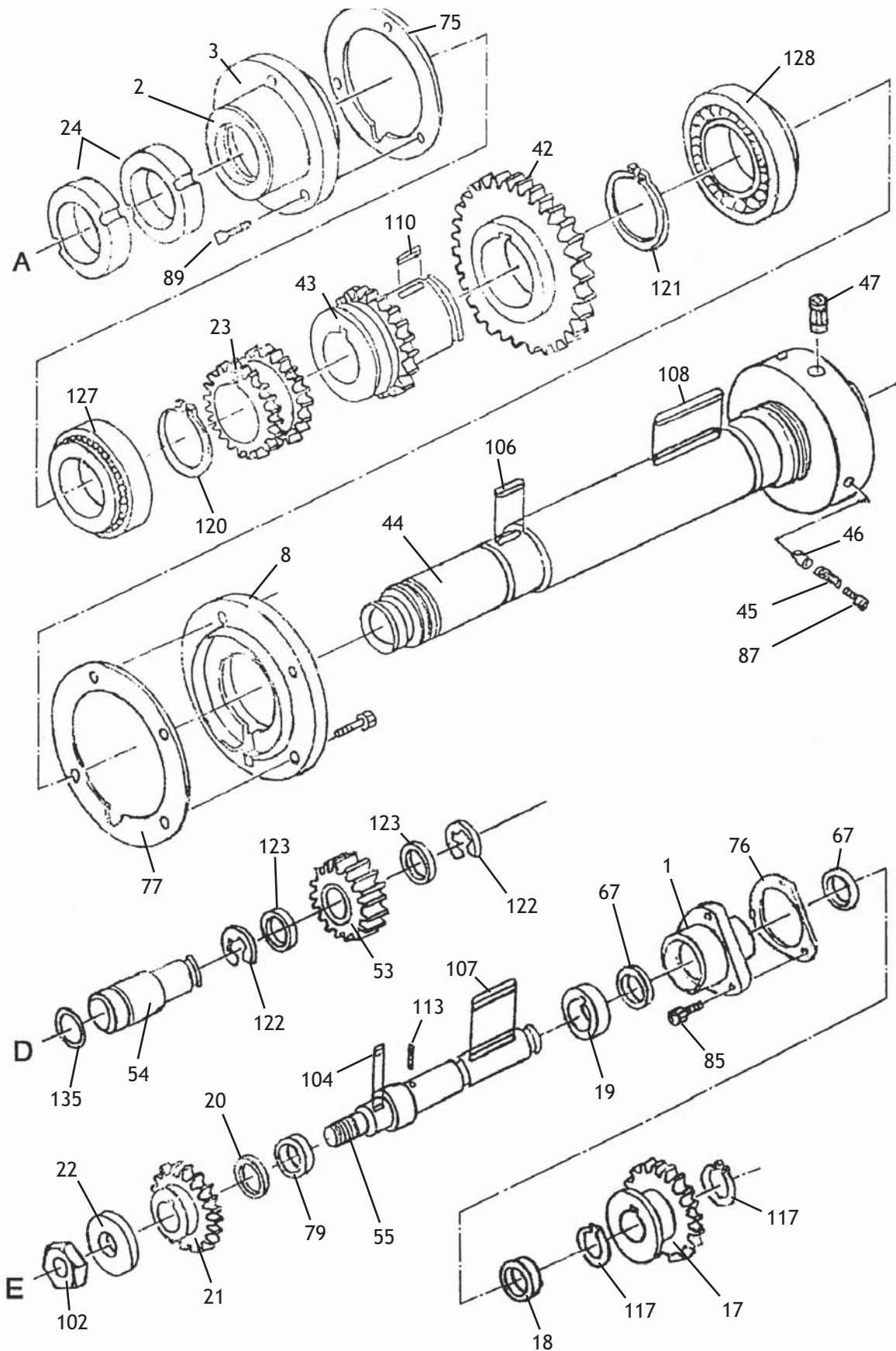

Figure 88. V-belt adjustments.



Headstock Gears 1



Headstock Gears 2

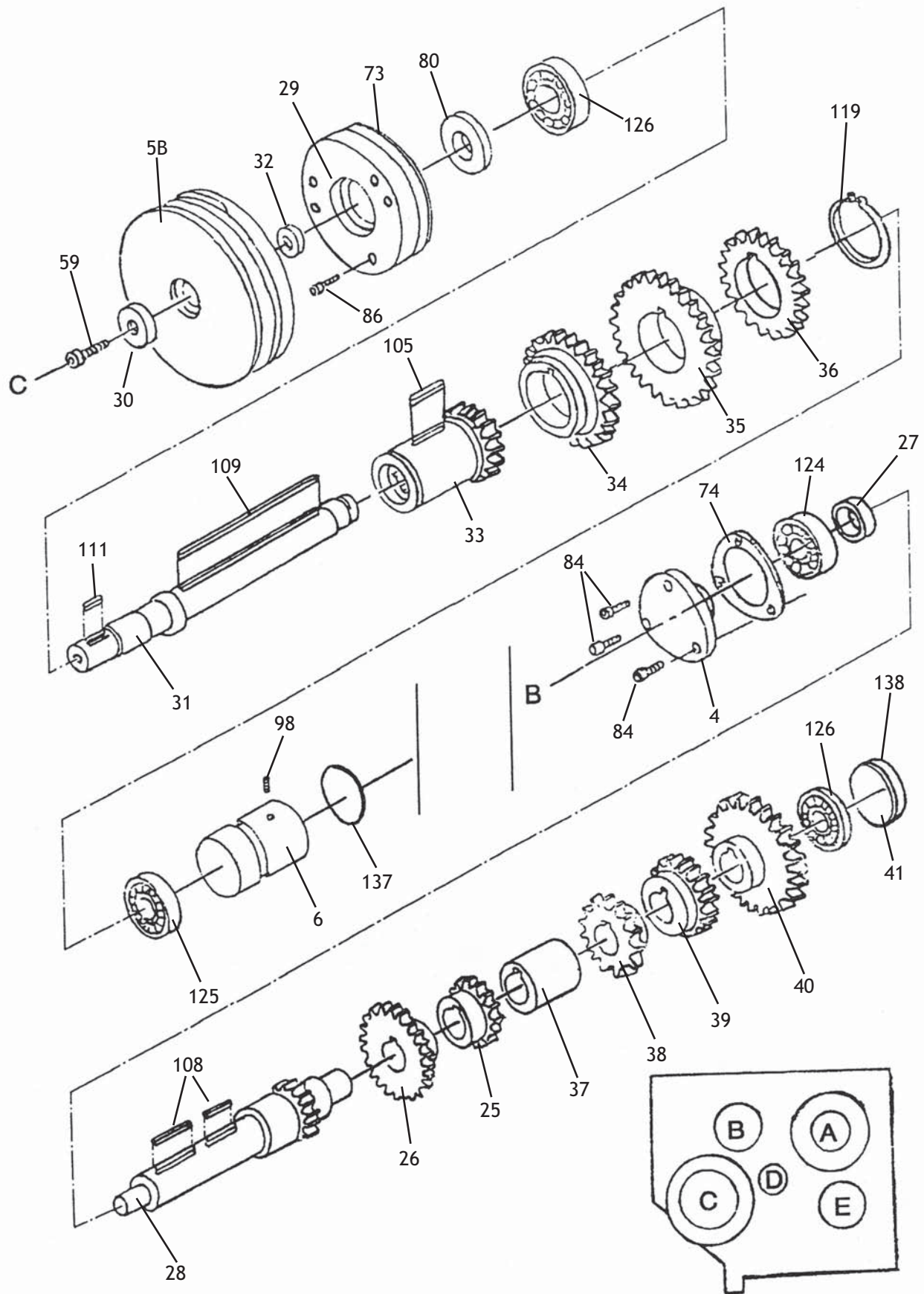

Headstock Case

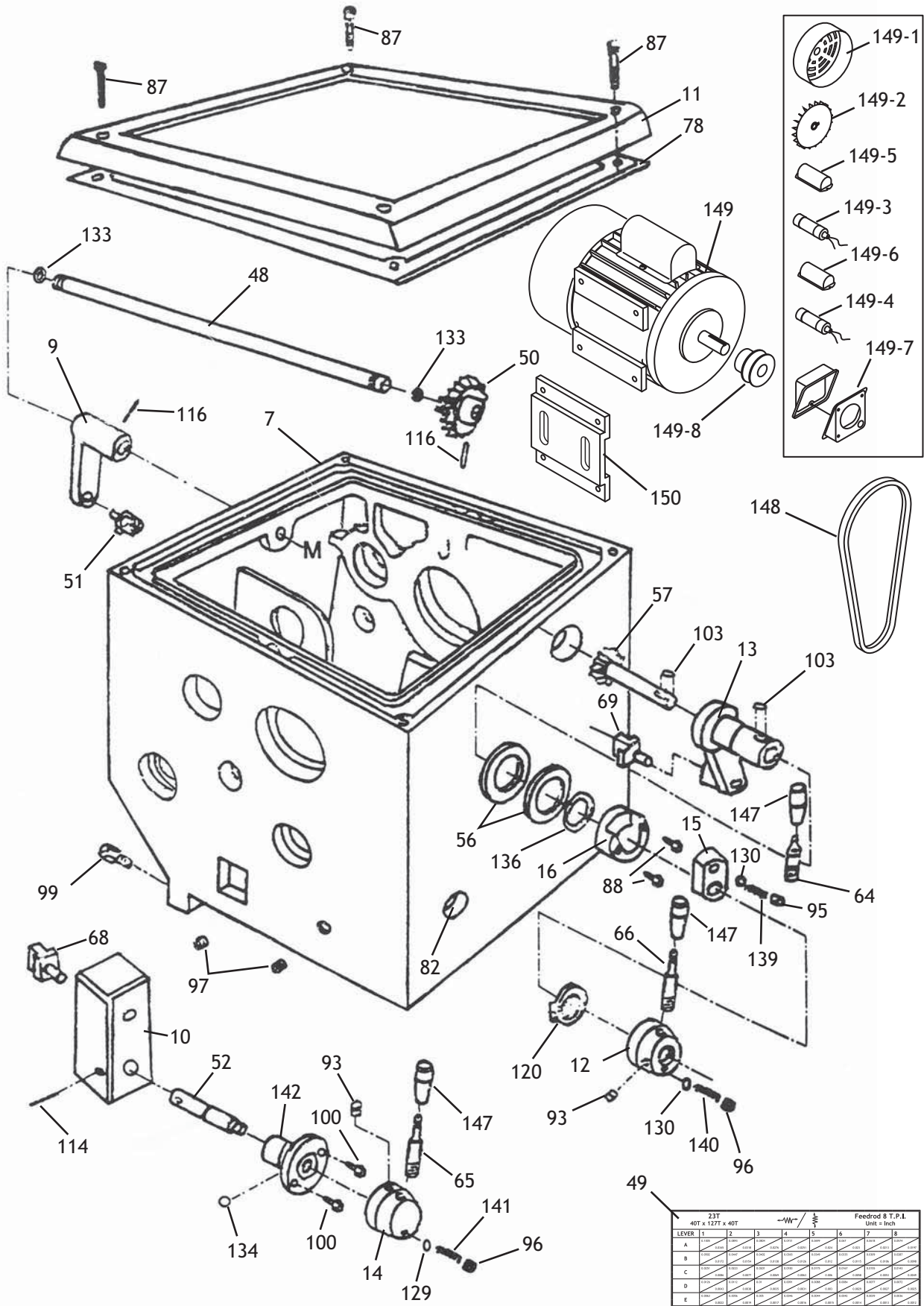

REF	PART #	DESCRIPTION
1	P4016001	COLLAR
2	P4016002	COLLAR
3	P4016003	REAR COVER
4	P4016004	REAR COVER
5B	P4016005B	PULLEY
6	P4016006	PLUG
7	P4016007	MAIN CASTING
8	P4016008	FRONT COVER
9	P4016009	SHIFT LEVER
10	P4016010	SHAFT HOUSING
11	P4016011	COVER
12	P4016012	HANDLE BODY
13	P4016013	SHAFT COLLAR
14	P4016014	HANDLE BODY
15	P4016015	HANDLE BLOCK
16	P4016016	HUB
17	P4016017	GEAR 37T
18	P4016018	SPACER
19	P4016019	SPACER
20	P4016020	SPACER
21	P4016021	GEAR 40T
22	PW06M	FLAT WASHER 12MM
23	P4016023	GEAR 37T
24	P4016024	SPANNER NUT
25	P4016025	GEAR 43T
26	P4016026	GEAR 51T
27	P4016027	SPACER
28	P4016028	GEAR SHAFT 16T
29	P4016029	COVER
30	P4016030	SPACER
31	P4016031	SHAFT
32	P4016032	SPACER
33	P4016033	COLLAR W/GEAR 21T

REF	PART #	DESCRIPTION
34	P4016034	GEAR 29T
35	P4016035	GEAR 46T
36	P4016036	GEAR 38T
37	P4016037	COLLAR
38	P4016038	GEAR 26T
39	P4016039	GEAR 34T
40	P4016040	GEAR 53T
41	P4016041	PLUG
42	P4016042	GEAR 74T
43	P4016043	GEAR SHAFT 37T
44	P4016044	SPINDLE
45	P4016045	SPRING
46	P4016046	LOCKING PIN
47	P4016047	CAMLOCK
48	P4016048	SHAFT
49	P4016049	GEAR FEED CHART
50	P4016050	GEAR 51T
51	P4016051	COLLAR
52	P4016052	SHAFT
53	P4016053	GEAR 30T
54	P4016054	SHAFT
55	P4016055	SHAFT
56	P4016056	FLAT WASHER 30MM
57	P4016057	GEAR SHAFT 17T
59	PSB31M	CAP SCREW M8-1.25 X 25
64	P4016064	HANDLE
65	P4016065	HANDLE
66	P4016066	HANDLE
67	P4016067	COLLAR
68	P4016068	SHIFT FORK
69	P4016069	SHIFT FORK
73	P4016073	GASKET



REF	PART #	DESCRIPTION
74	P4016074	GASKET
75	P4016075	GASKET
76	P4016076	GASKET
77	P4016077	GASKET
78	P4016078	GASKET
79	P4016079	OIL SEAL
80	P4016080	OIL SEAL
82	P4016082	OIL SIGHT GLASS
84	PSB23M	CAP SCREW M4-.7 X 12
85	PSB24M	CAP SCREW M5-.8 X 16
86	PSB26M	CAP SCREW M6-1 X 12
87	PSB14M	CAP SCREW M8-1.25 X 20
88	PSB02M	CAP SCREW M6-1 X 20
89	PSB06M	CAP SCREW M6-1 X 25
93	PSS04M	SET SCREW M6-1 X 12
95	PSS20M	SET SCREW M8-1.25 X 8
96	PSS16M	SET SCREW M8-1.25 X 10
97	PSS14M	SET SCREW M8-1.25 X 12
98	PSS06M	SET SCREW M8-1.25 X 16
99	PSB45M	CAP SCREW M8-1.25 X 45
100	PS07M	PHLP HD SCR M4-.7 X 8
102	PN09M	HEX NUT M12-1.75
103	PK20M	KEY 5 X 15
104	PK14M	KEY 5 X 18
105	PK36M	KEY 5 X 50
106	PK11M	KEY 6 X 40
107	PK44M	KEY 6 X 50
108	PK49M	KEY 6 X 55
109	PK50M	KEY 6 X 120
110	PK51M	KEY 8 X 18
111	PK34M	KEY 5 X 20
113	PRP44M	ROLL PIN 3 X 10
114	PRP01M	ROLL PIN 4 X 18
116	PRP45M	ROLL PIN 5 X 32
117	PR09M	EXT RETAINING RING 20MM

REF	PART #	DESCRIPTION
119	PR12M	EXT RETAINING RING 35MM
120	PR43M	EXT RETAINING RING 50MM
121	PR44M	EXT RETAINING RING 72MM
122	PR24M	E-CLIP 42MM
123	P4016123	BALL BEARING 7004ZZ
124	P6204	BALL BEARING 6204ZZ
125	P6203	BALL BEARING 6203ZZ
126	P6204	BALL BEARING 6204ZZ
127	P30210	BALL BEARING 30210
128	P7212	BALL BEARING 7212D
129	P4016129	STEEL BALL 5MM
130	P4016130	STEEL BALL 6MM
133	P4016133	O-RING 2.4 X 14
134	P4016134	O-RING 2.4 X 20
135	P4016135	O-RING 2.4 X 25
136	P4016136	O-RING 3.1 X 30
137	P4016137	O-RING 3.1 X 40
138	P4016138	O-RING 3.1 X 47
139	P4016139	SPRING 1 X 6 X 7
140	P4016140	SPRING 1 X 6 X 25
141	P4016141	SPRING 0.9 X 4.4 X 19
142	P4016142	SHIFT HUB
147	P4016147	LEVER SLEEVE
148	PVA32	V-BELT A-32 4L320
149	P4016149	MOTOR
149-1	P4016149-1	MOTOR FAN COVER
149-2	P4016149-2	MOTOR FAN
149-3	P4016149-3	START CAPACITOR 200MF 250V
149-4	P4016149-4	RUN CAPACITOR 20MF 440/450V
149-5	P4016149-5	START CAPACITOR COVER
149-6	P4016149-6	RUN CAPACITOR COVER
149-7	P4016149-7	MOTOR ELECTRICAL BOX
149-8	P4016149-8	MOTOR PULLEY
150	P4016150	MOTOR MOUNT



Lathe Bed

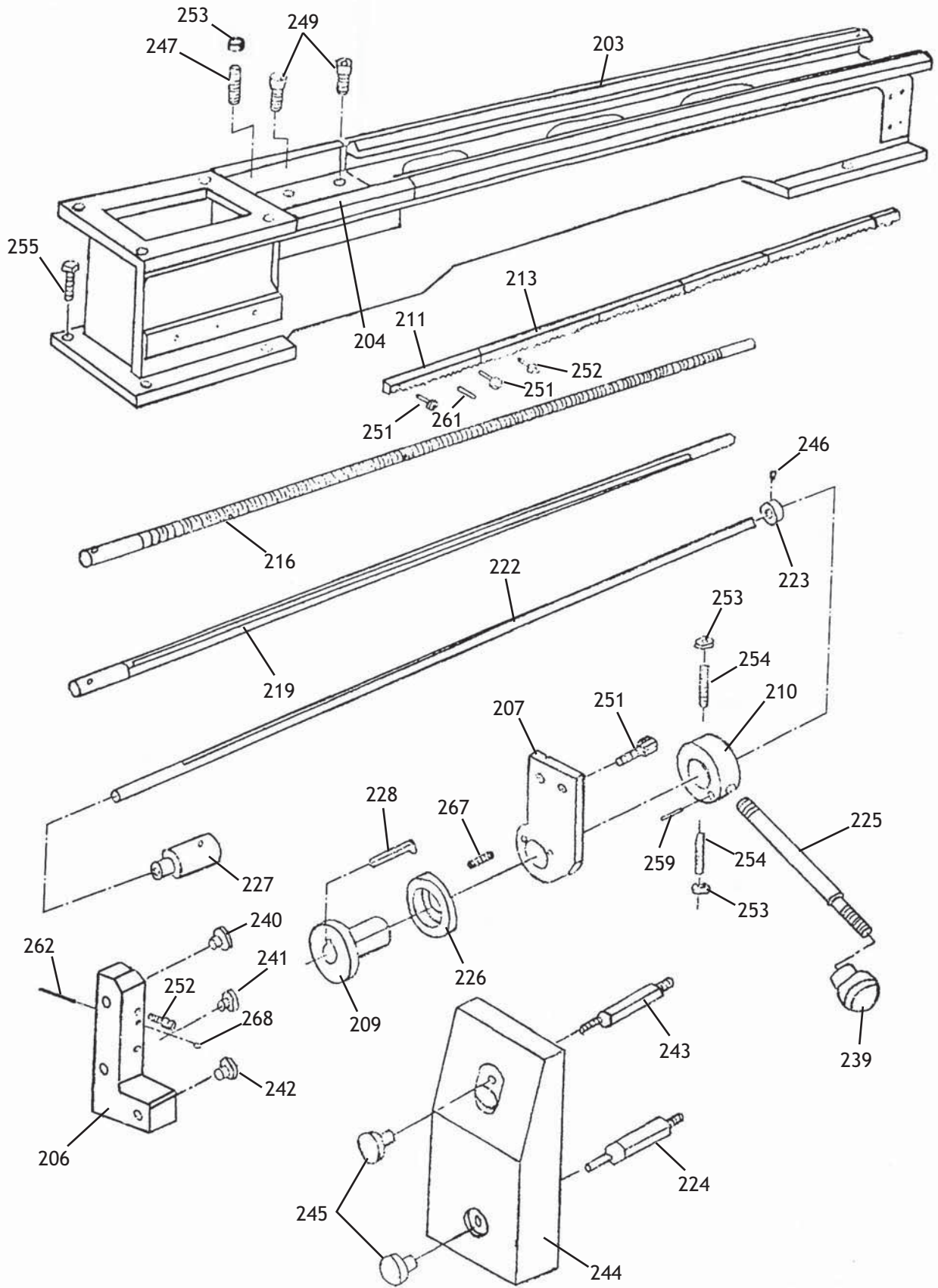

REF	PART #	DESCRIPTION
150	P4016150	MOTOR MOUNT
203	P4016203	BED
204	P4016204	GAP
206	P4016206	BRACKET
207	P4016207	BRACKET
209	P4016209	COLLAR
210	P4016210	HANDLE BODY
211	P4016211	RACK
213	P4016213	RACK
216	P4016216	LEAD SCREW
219	P4016219	FEED ROD
222	P4016222	SHAFT
223	P4016223	COLLAR
224	P4016224	THREADED SHAFT
225	P4016225	HANDLE
226	P4016226	BRAKE RING
227	P4016227	COLLAR
228	P4016228	KEY 4 X 35
239	P4016239	KNOB M10-1.5

REF	PART #	DESCRIPTION
240	P4016240	PLUG
241	P4016241	PLUG
242	P4016242	PLUG
243	P4016243	THREADED SHAFT
244	P4016244	COVER
245	P4016245	LOCK KNOB M8-1.25
246	PSS31M	SET SCREW M5-.8 X 8
247	PSS06M	SET SCREW M8-1.25 X 16
249	PSB47M	CAP SCREW M10-1.5 X 40
251	PSB02M	CAP SCREW M6-1 X 20
252	PSB60M	CAP SCREW M8-1.25 X 55
253	PN03M	HEX NUT M8-1.25
254	PSS19M	SET SCREW M8-1.25 X 30
255	PB38M	HEX BOLT M12-1.75 X 60
259	P4016259	ROUND PIN 6 X 25
261	PRP46M	ROLL PIN 6 X 28
262	PRP34M	ROLL PIN 6 X 55
267	P4016267	SPRING 1 X 7.5 X 25
268	P4016268	OIL PORT 8MM



Gearbox Case

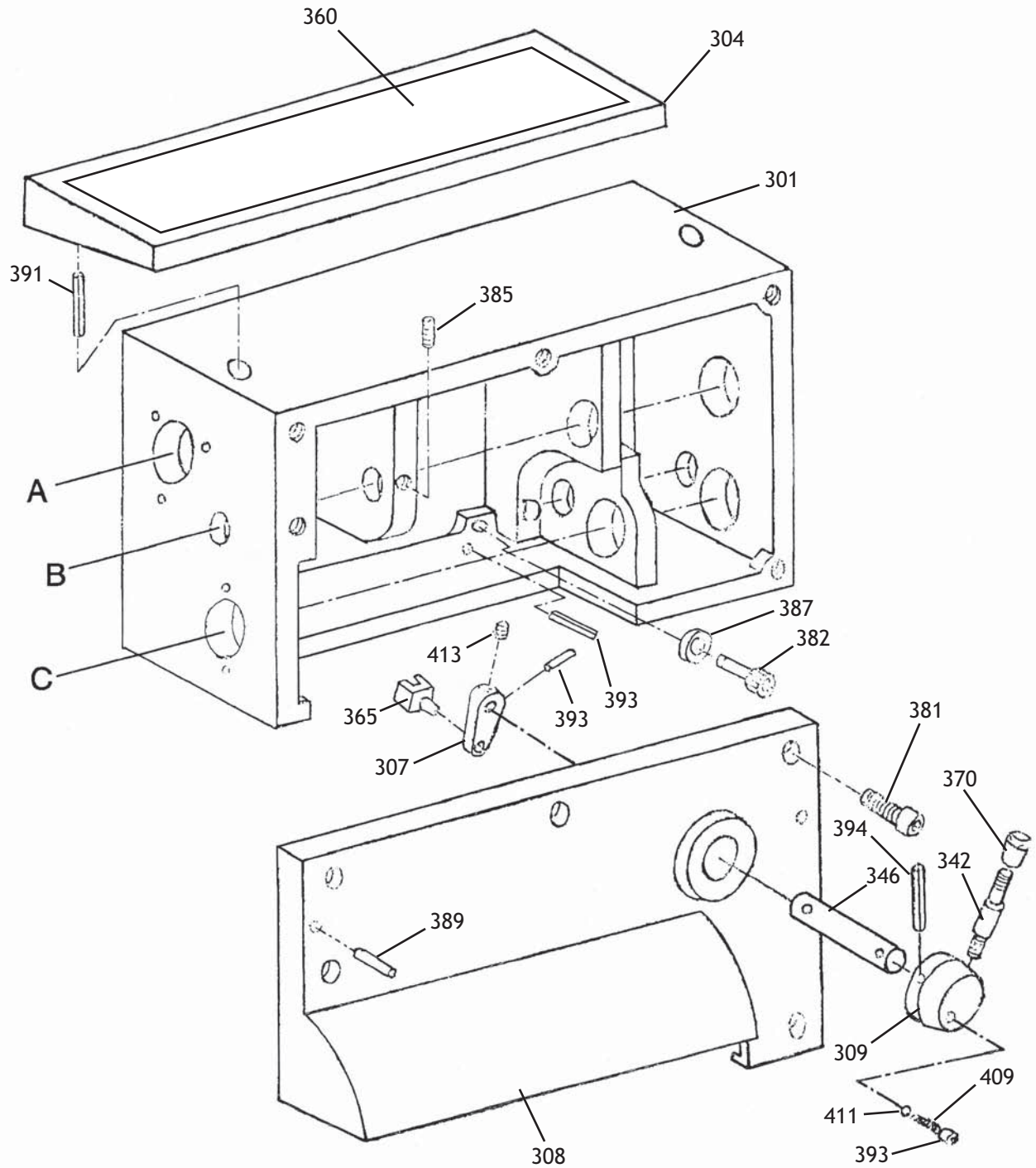

Gearbox Components

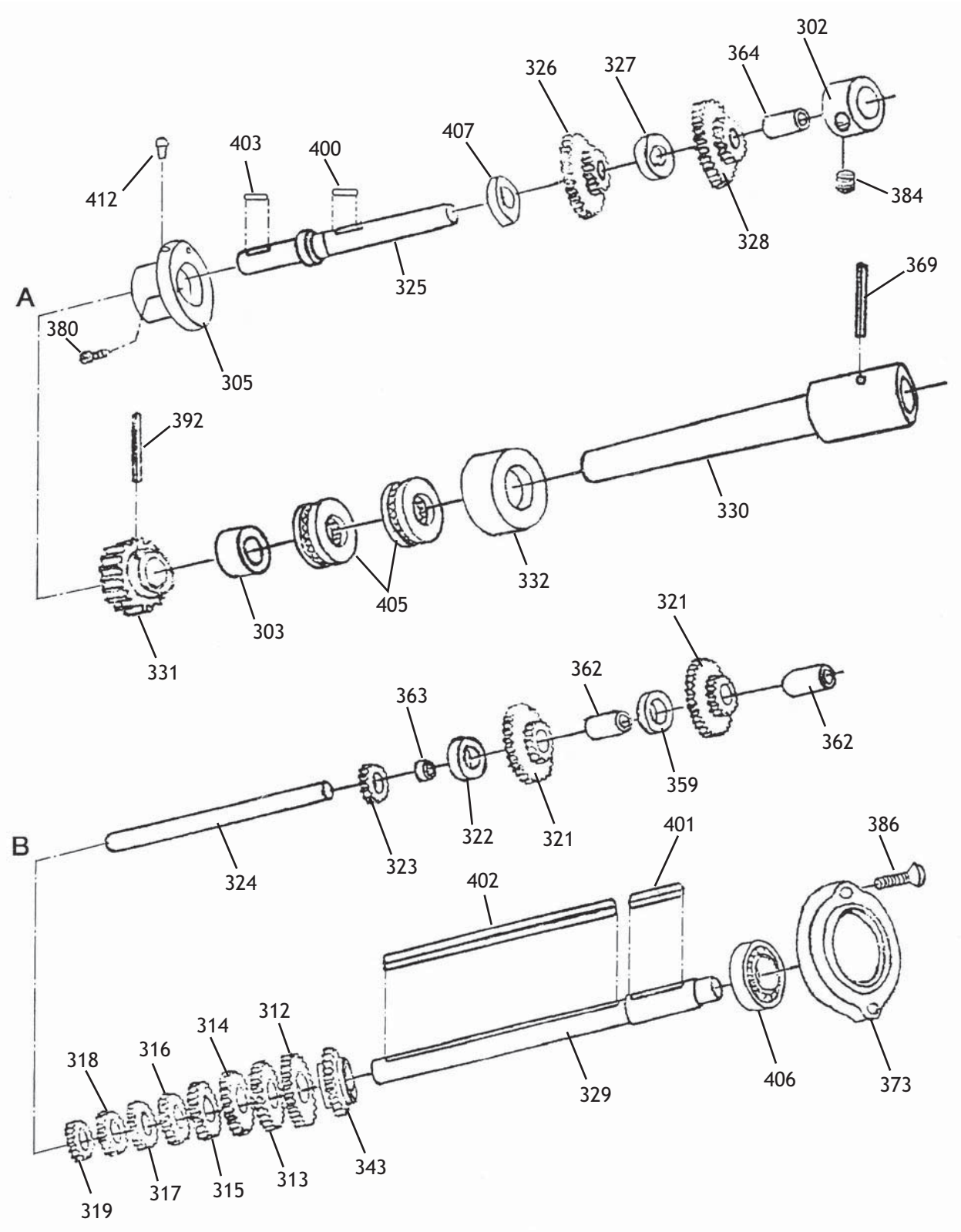

Change Gear Assembly

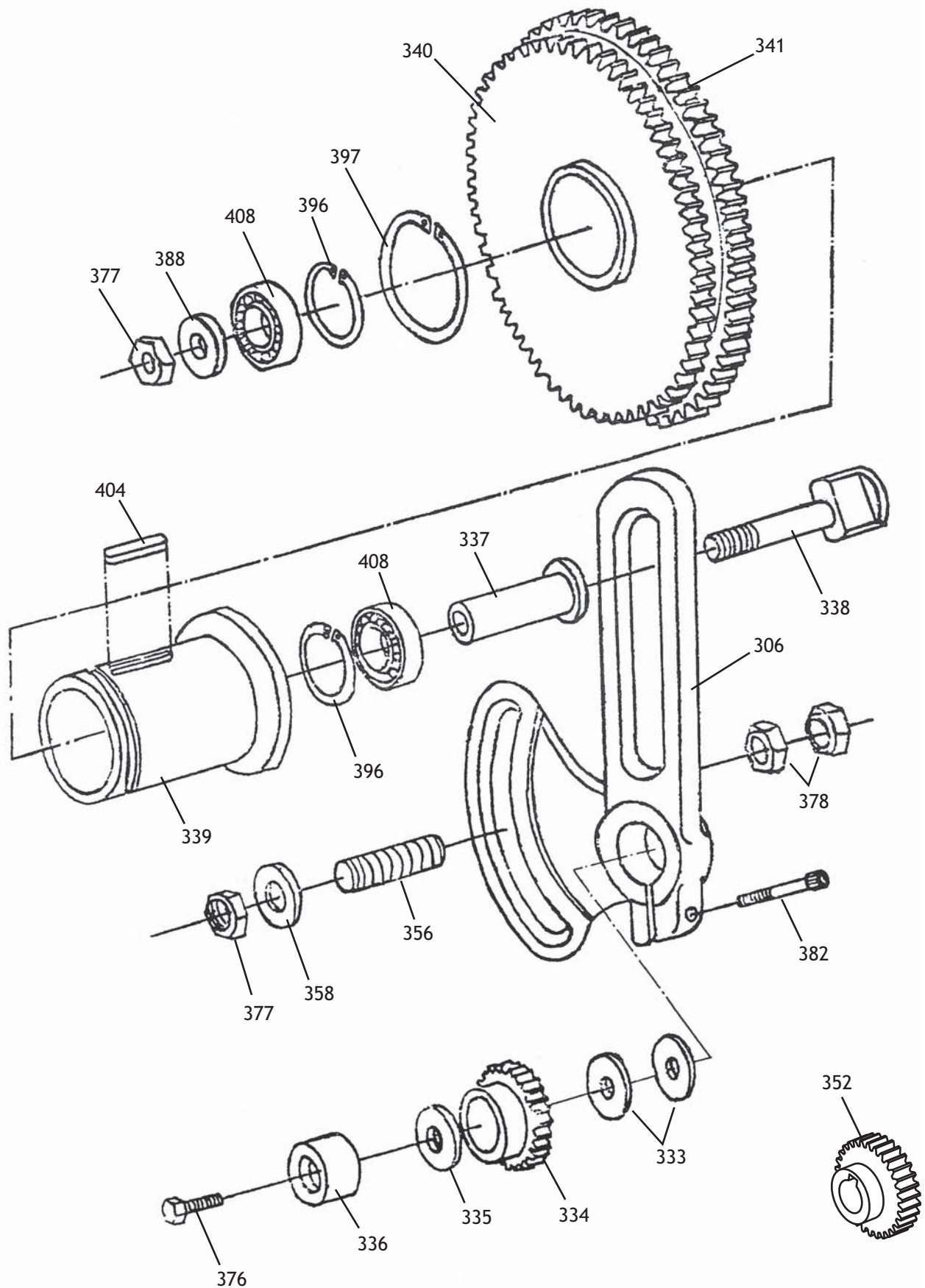

Gear Lever Assembly

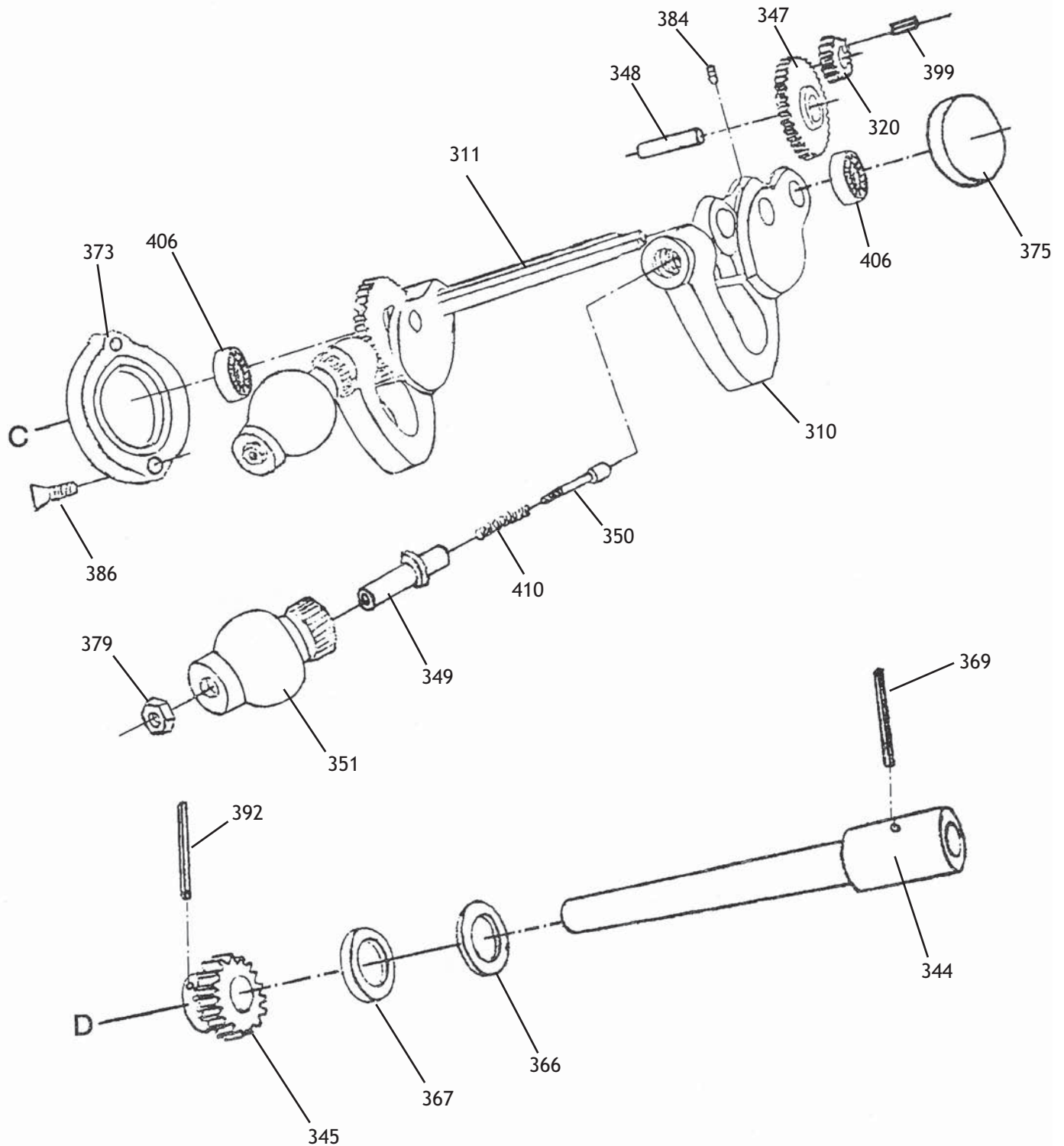

REF	PART #	DESCRIPTION
301	P4016301	GEARBOX CASTING
302	P4016302	LOCK COLLAR
303	P4016303	COLLAR
304	P4016304	COVER
305	P4016305	BEARING CAP
306	P4016306	BRACKET
307	P4016307	LEVER ARM
308	P4016308	GEARBOX COVER
309	P4016309	HANDLE BODY
310	P4016310	HANDLE BODY
311	P4016311	LEVER SHAFT
312	P4016312	GEAR 28T
313	P4016313	GEAR 26T
314	P4016314	GEAR
315	P4016315	GEAR 23T
316	P4016316	GEAR 22T
317	P4016317	GEAR 20T
318	P4016318	GEAR 18T
319	P4016319	GEAR 16T
320	P4016320	GEAR 16T
321	P4016321	GEAR 32/16T
322	P4016322	COVER
323	P4016323	GEAR 16T
324	P4016324	SHAFT
325	P4016325	SHAFT
326	P4016326	GEAR 32/16T
327	P4016327	COVER
328	P4016328	GEAR 82/16T
329	P4016329	SHAFT
330	P4016330	SHAFT
331	P4016331	GEAR 40T
332	P4016332	BEARING BRIDGE
333	P4016333	COLLAR
334	P4016334	GEAR 40T
335	P4016335	COLLAR
336	P4016336	SHAFT COVER
337	P4016337	COLLAR
338	P4016338	SPECIAL SCREW
339	P4016339	COLLAR
340	P4016340	GEAR 120T
341	P4016341	GEAR 127T
342	P4016342	LEVER
343	P4016343	GEAR 24T
344	P4016344	SHAFT
345	P4016345	GEAR 24T
346	P4016346	SHAFT
347	P4016347	GEAR 32T
348	P4016348	SHAFT
349	P4016349	SHAFT
350	P4016350	THREADED PIN

REF	PART #	DESCRIPTION
351	P4016351	KNOB
352	P4016352	CHANGE GEAR 30T
356	P4016356	STUD M10-1.5 X 60
358	PW04M	FLAT WASHER 10MM
359	P4016359	COLLAR
360	P4016360	PLATE W/FEED CHART
362	P4016362	COVER SLEEVE
363	P4016363	COLLAR
364	P4016364	BUSHING
365	P4016365	SLIP FITTING
366	P4016366	COLLAR
367	P4016367	COLLAR
369	P4016369	TAPER PIN 3 X 32
370	P4016370	KNOB M10-1.5
373	P4016373	COVER
375	P4016375	PLUG
376	PB04M	HEX BOLT M6-1 X 10
377	PN02M	HEX NUT M10-1.5
378	PN02M	HEX NUT M10-1.5
379	PN01M	HEX NUT M6-1
380	PSB02M	CAP SCREW M6-1 X 20
381	PSB01M	CAP SCREW M6-1 x 16
382	PSB40M	CAP SCREW M8-1.25 X 35
384	PSS07M	SET SCREW M5-.8 X 5
385	PSS31M	SET SCREW M5-.8 X 8
386	PFH05M	FLAT HD SCR M5-.8 X 12
387	PW01M	FLAT WASHER 8MM
388	PW04M	FLAT WASHER 10MM
389	PRP52M	ROLL PIN 6 X 16
391	PRP70M	ROLL PIN 5 X 18
392	PRP27M	ROLL PIN 5 X 28
393	PRP45M	ROLL PIN 5 X 32
394	PRP28M	ROLL PIN 5 X 40
396	PR23M	INT RETAINING RING 40MM
397	P4016397	EXT RETAINING RING 55MM
399	PK05M	KEY 4 X 4 X 10
400	PK47M	KEY 4 X 4 X 15
401	PK68M	KEY 4 X 4 X 40
402	PK18M	KEY 4 x 4 x 82
403	PK20M	KEY 5 X 5 X 15
404	PK07M	KEY 6 x 6 x 20
405	P8103	THRUST BEARING 8103
406	P4016406	BEARING 2G80102 15 x 32 x 9
407	P6003	BALL BEARING 6003ZZ
408	P6203A	BALL BEARING P6203Z
409	P4016409	SPRING 0.8 X 4.5 X 70
410	P4016410	SPRING 1 x 1.9 x 70
411	P4016129	STEEL BALL 5MM
412	P4016412	OILER 6MM
413	PSS05M	SET SCREW M5-.8 X 10



Apron Case

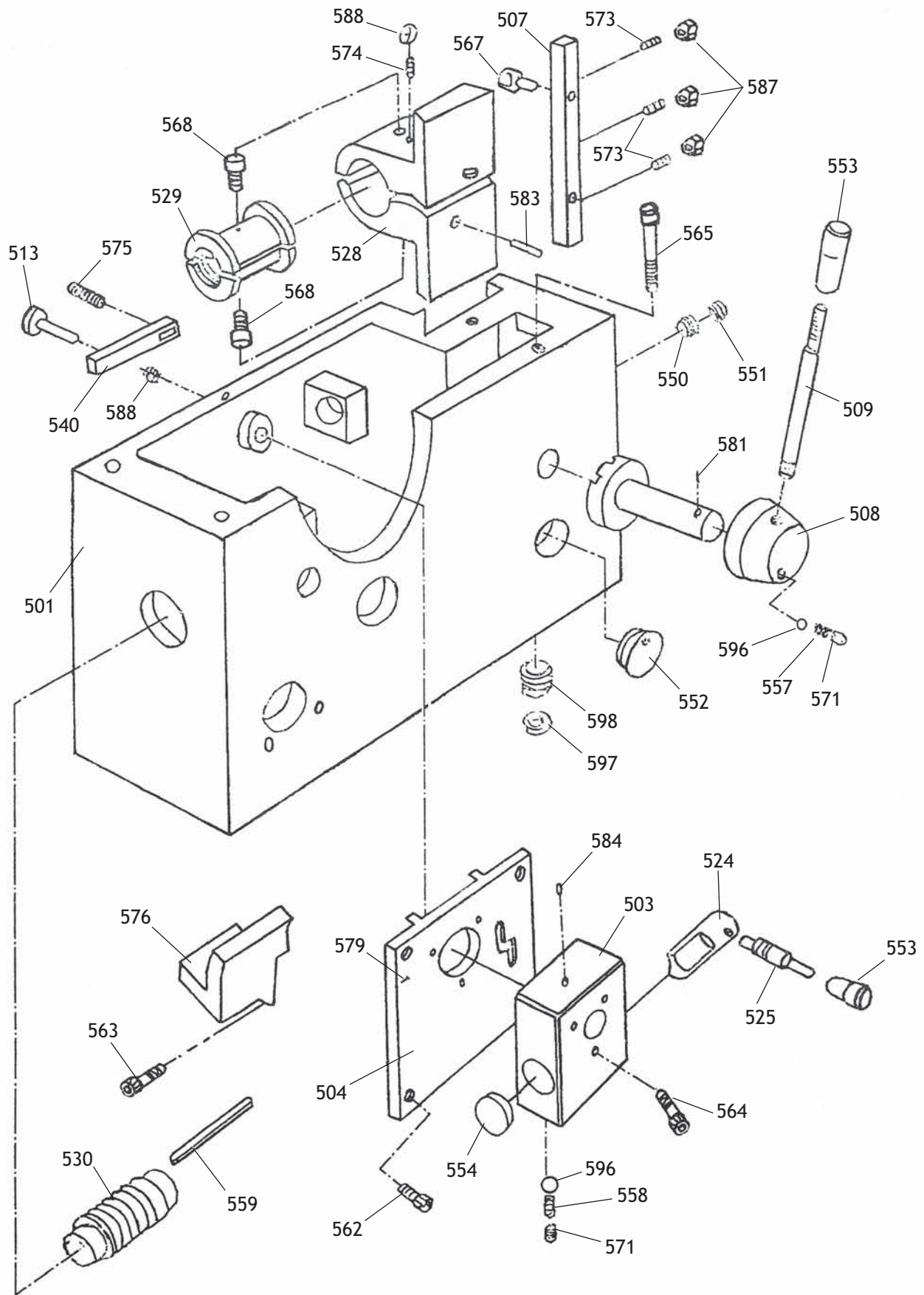

Apron Gears

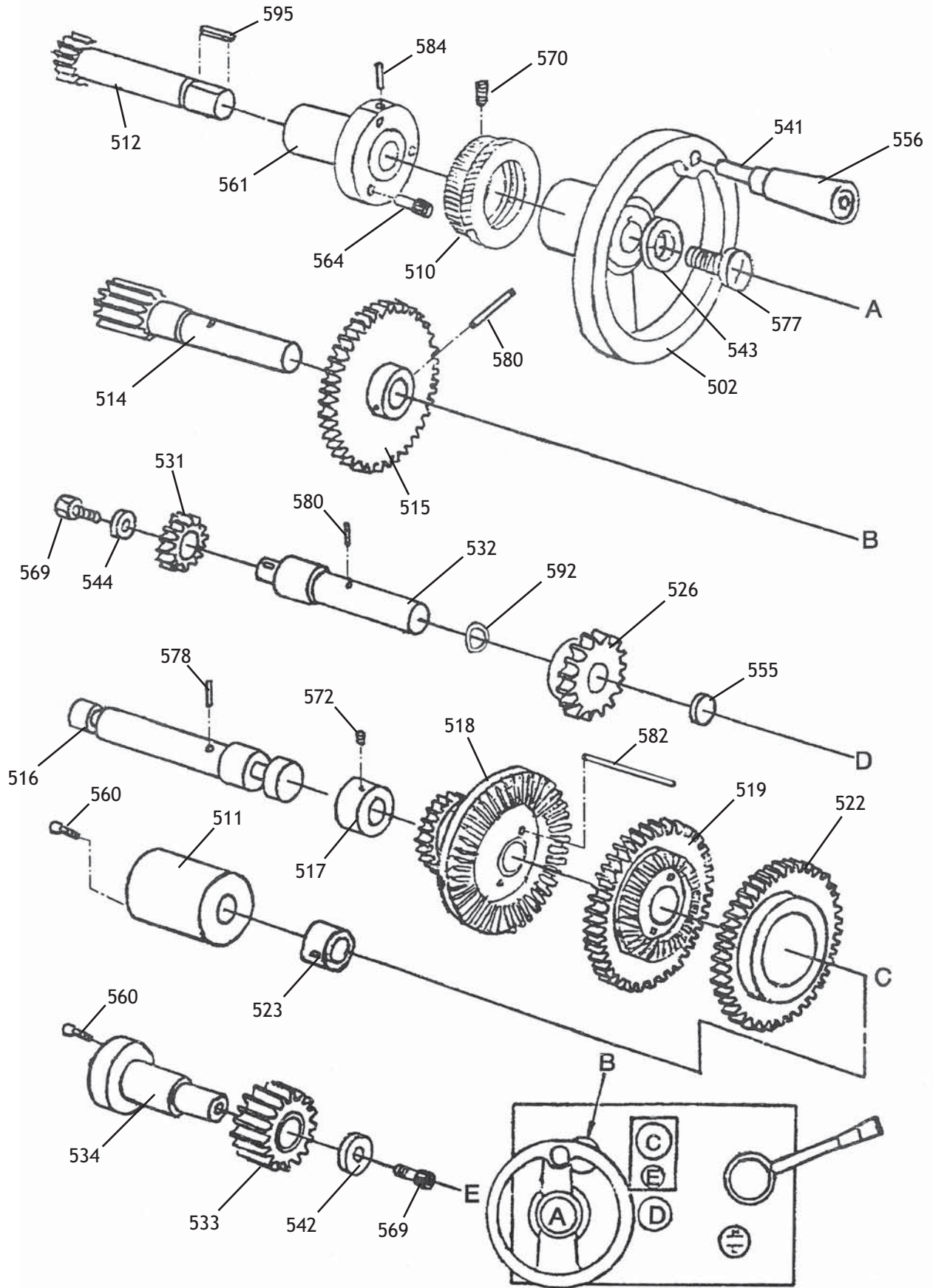

Thread Dial

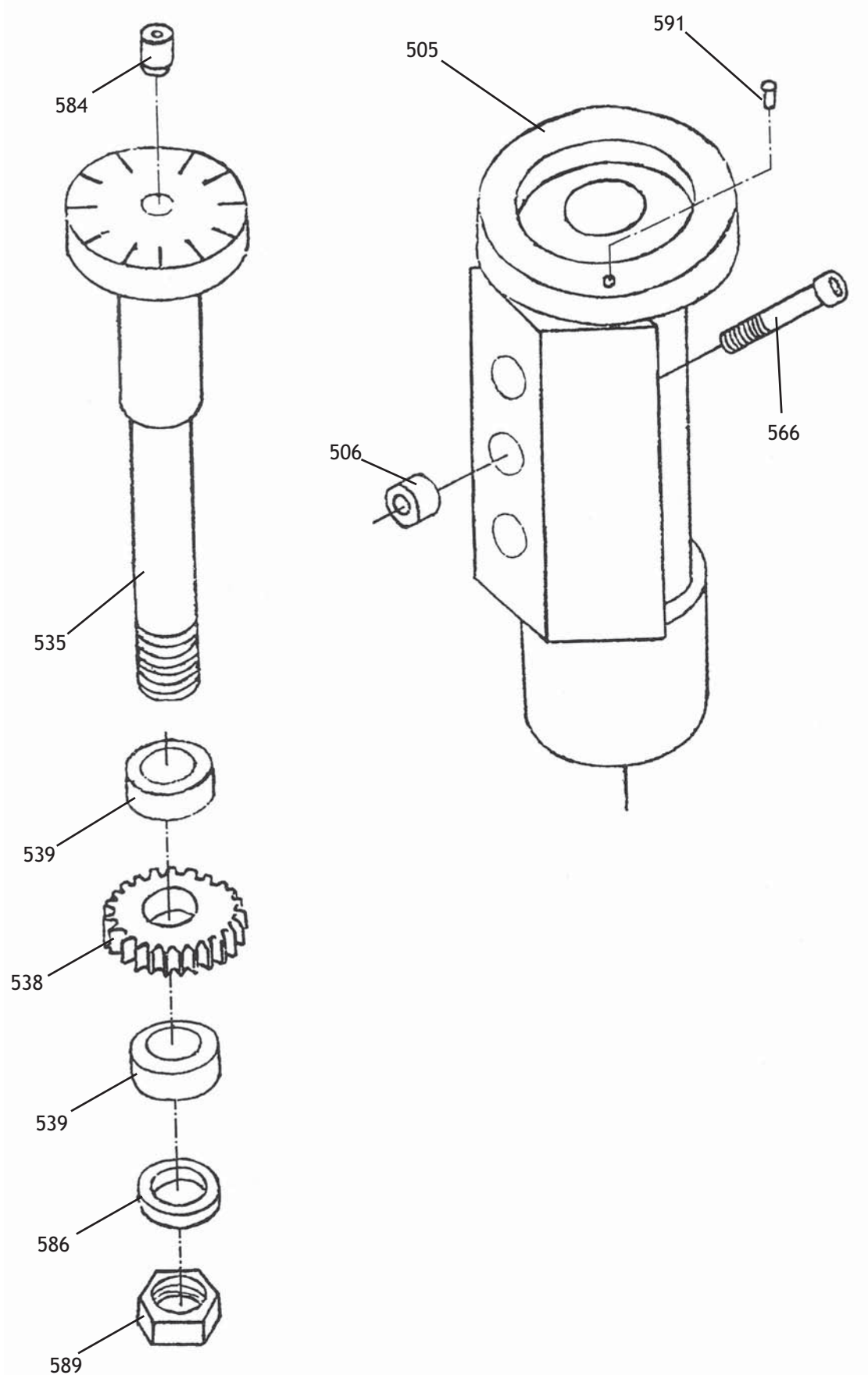

REF	PART #	DESCRIPTION
501	P4016501	APRON CASTING
502	P4016502	HANDWHEEL
503	P4016503	BOX
504	P4016504	COVER
505	P4016505	THREADING DIAL BODY
506	P4016506	SPACER
507	P4016507	GIB
508	P4016508	HANDLE BODY
509	P9036509	HANDLE
510	P4016510	INDEX RING
511	P4016511	COVER
512	P4016512	SHAFT
513	P4016513	GEAR PIN 60T
514	P4016514	GEAR SHAFT 13T
515	P4016515	GEAR 60T
516	P4016516	SHAFT
517	P4016517	COVER
518	P4016518	GEAR 30T
519	P4016519	GEAR 46T
522	P4016522	GEAR 63T
523	P4016523	SHIFT FORK
524	P4016524	SHIFT LEVER
525	P4016525	SHIFT HANDLE
526	P4016526	GEAR 40T
528	P4016528	BRACKET
529	P4016529	HALF NUT
530	P4016530	WORM
531	P4016531	GEAR 22T
532	P4016532	SHAFT
533	P4016533	GEAR 18T
534	P4016534	SHAFT
535	P4016535	THREADING DIAL SHAFT
538	P4016538	GEAR 32T
539	P4016539	SPACER
540	P4016540	BAR
541	P4016541	SPECIAL BOLT M8-1.25 X 13
542	PW03M	FLAT WASHER 6MM
543	PW03M	FLAT WASHER 6MM
544	PW03M	FLAT WASHER 6MM
550	P4016550	OIL SIGHT COLLAR
551	P4016551	OIL SIGHT COLLAR
552	P4016552	OIL SIGHT GLASS

REF	PART #	DESCRIPTION
553	P4016553	KNOB M8-1.25
554	P4016554	PLUG "A"
555	P4016555	PLUG "B"
556	P4016556	HANDLE
557	P4016557	COMPRESSION SPRING
558	P4016558	COMPRESSION SPRING
559	PK15M	KEY 5 X 5 X 35
560	PSB33M	CAP SCREW M5-.8 X 12
561	P4016561	HUB
562	PSB26M	CAP SCREW M6-1 X 12
563	PSB01M	CAP SCREW M6-1 x 16
564	PSB06M	CAP SCREW M6-1 X 25
565	PSB13M	CAP SCREW M8-1.25 X 30
566	PSB05M	CAP SCREW M8-1.25 X 50
567	PSB24M	CAP SCREW M5-.8 X 16
568	PSB26M	CAP SCREW M6-1 X 12
569	PSB04M	CAP SCREW M6-1 X 10
570	PSS26M	SET SCREW M5-.8 X 6
571	PSS02M	SET SCREW M6-1 X 6
572	PSS01M	SET SCREW M6-1 X 10
573	PSS34M	SET SCREW M5-.8 X 16
574	PSS29M	SET SCREW M6-1 X 35
575	PSS01M	SET SCREW M6-1 X 10
576	P4016576	BRACKET
577	PSB26M	CAP SCREW M6-1 X 12
578	PRP16M	ROLL PIN 3 X 25
579	PRP03M	ROLL PIN 5 X 20
580	PRP05M	ROLL PIN 5 X 30
581	PRP45M	ROLL PIN 5 X 32
582	PRP49M	ROLL PIN 5 X 25
583	PRP83M	ROLL PIN 8 X 12
584	P4016584	OILER 8MM
586	PLW04M	LOCK WASHER 8MM
587	PN06M	HEX NUT M5-.8
588	PN01M	HEX NUT M6-1
589	PN03M	HEX NUT M8-1.25
591	P4016591	RIVET 3 X 8
592	P4016592	O-RING 20 X 2.4
595	PK14M	KEY 5 X 5 X 18
596	P4016596	STEEL BALL 5MM
597	PW04M	FLAT WASHER 10MM
598	P4016598	PLUG M10-1.5 X 1



Carriage Assembly

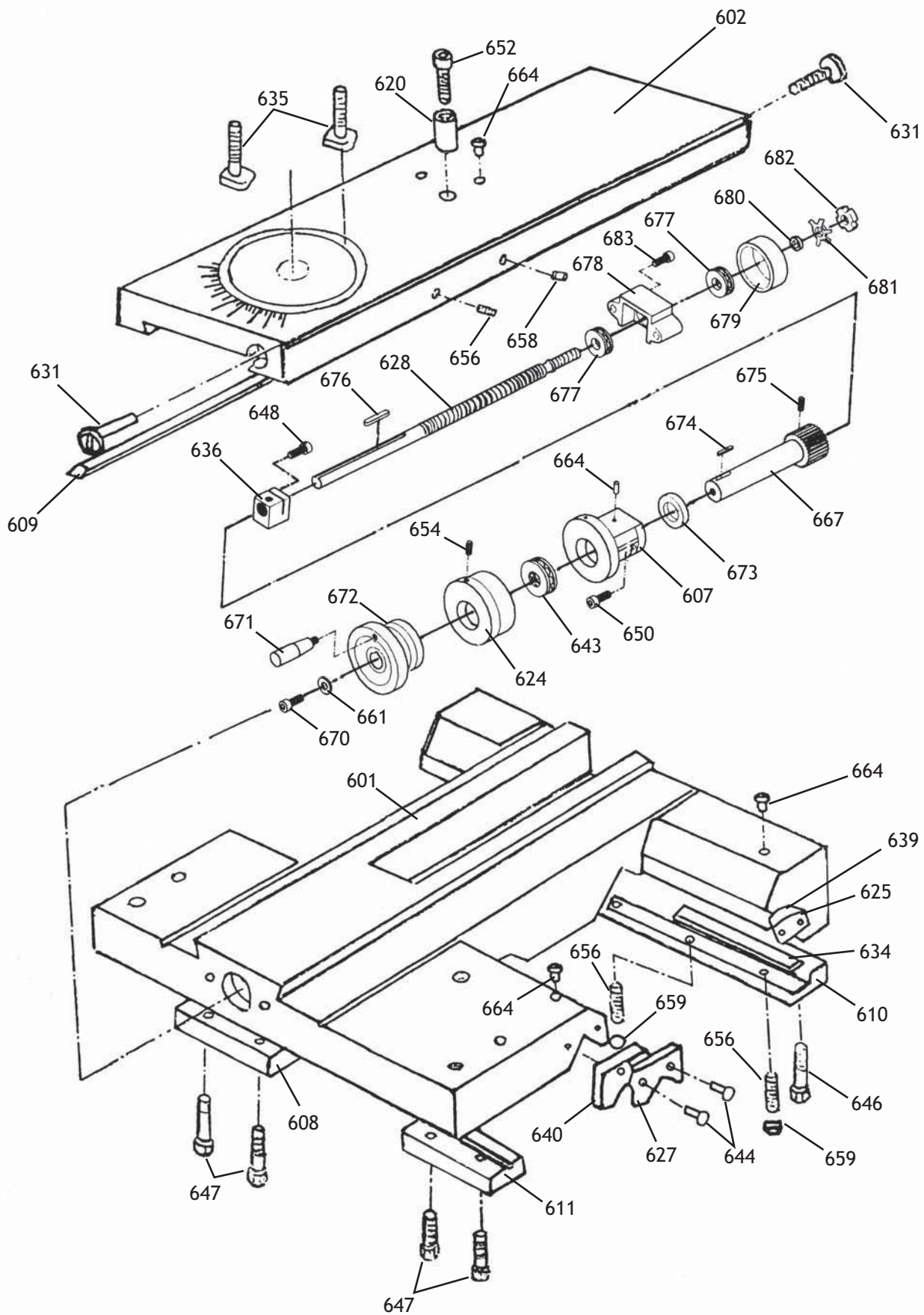

Cross Slide Assembly

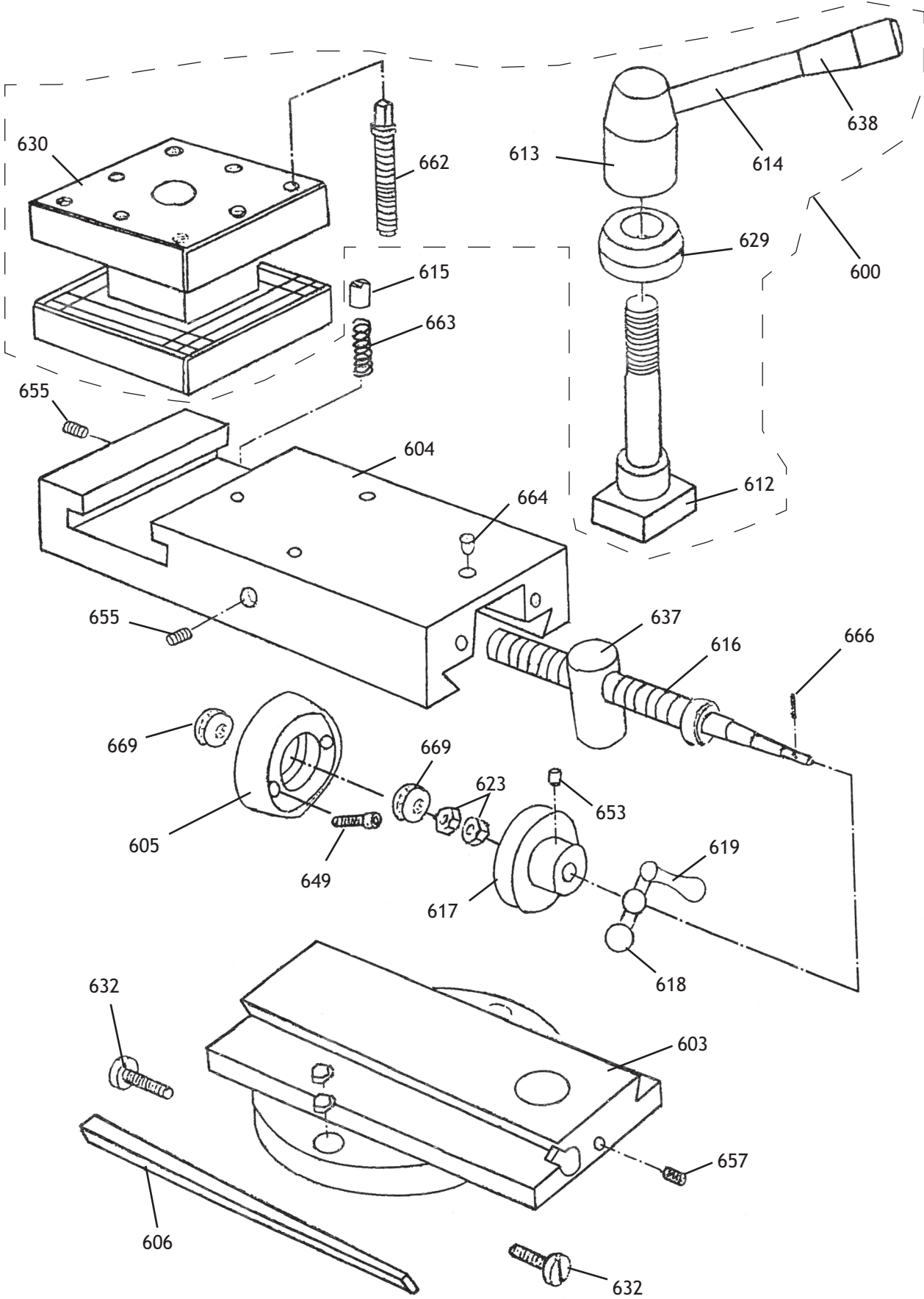

REF	PART #	DESCRIPTION
600	P4016600	COMPLETE TOOL POST ASSY
601	P4016601	SADDLE
602	P4016602	CROSS SLIDE
603	P4016603	SWIVEL SLIDE
604	P4016604	TOP SLIDE
605	P4016605	COLLAR
606	P4016606	GIB
607	P4016607	HUB
608	P4016608	STRIP
609	P4016609	GIB
610	P4016610	STRIP
611	P4016611	FRONT STRIP
612	P4016612	SPECIAL T-BOLT
613	P4016613	HANDLE BASE
614	P4016614	HANDLE SHAFT
615	P4016615	STOP
616	P4016616	LEAD SCREW
617	P4016617	INDEX RING
618	P4016618	HAND CRANK
619	P4016619	HANDLE
620	P4016620	COLLAR
623	PN09M	HEX NUT M12-1.75
624	P4016624	INDEXING RING
625	P4016625	PLATE
627	P4016627	PLATE
628	P4016628	CROSS SLIDE LEAD SCREW N/S
629	P4016629	BEVELED COLLAR
630	P4016630	POST BASE
631	P4016631	GIB ADJUSTING SCREW
632	P4016632	GIB ADJUSTING SCREW
634	P4016634	GIB STRIP
635	P4016635	T-BOLT M8-1 X 42
636	P4016636	BLOCK
637	P4016637	LEADSCREW NUT
638	P4016638	HANDLE
639	P4016639	WIPER
640	P4016640	WIPER

REF	PART #	DESCRIPTION
643	P51102	THRUST BEARING 51102
644	PS02M	PHLP HD SCR M4-.7 X 12
646	PB09M	HEX BOLT M8-1.25 X 20
647	PB09M	HEX BOLT M8-1.25 X 20
648	PSB01M	CAP SCREW M6-1 x 16
649	PSB02M	CAP SCREW M6-1 X 20
650	PSB06M	CAP SCREW M6-1 X 25
652	PSB11M	CAP SCREW M8-1.25 X 16
653	PSS02M	SET SCREW M6-1 X 6
654	PSS03M	SET SCREW M6-1 X 8
655	PSS01M	SET SCREW M6-1 X 10
656	PSS11M	SET SCREW M6-1 X 16
657	PSS20M	SET SCREW M8-1.25 X 8
658	PSS16M	SET SCREW M8-1.25 X 10
659	PN01M	HEX NUT M6-1
661	PW01M	FLAT WASHER 8MM
662	P4016662	TOOL LOCK SCREW M10-1.5 X 40
663	P4016663	SPRING .6 X 4 X 18
664	P4016664	OILER 8MM
666	PRP02M	ROLL PIN 3 X 16
667	P4016667	GEAR
669	P51101	THRUST BEARING 51101
670	PSB11M	CAP SCREW M8-1.25 X 16
671	P4016671	HANDLE
672	P4016672	COMPOUND HANDWHEEL
673	P4016673	SPACER
674	PK48M	KEY 4 X 4 X 20
675	PSS45M	SET SCREW M3-.5 X 6
676	PK12M	KEY 5 X 5 X 30
677	P51101	THRUST BEARING 51101
678	P4016678	BEARING HOUSING
679	P4016679	BEARING DUST COVER
680	P4016680	SPACER
681	P4016681	TAB WASHER
682	P4016682	LOCKING NUT
683	PSB31M	CAP SCREW M8-1.25 X 25



Tailstock Assembly

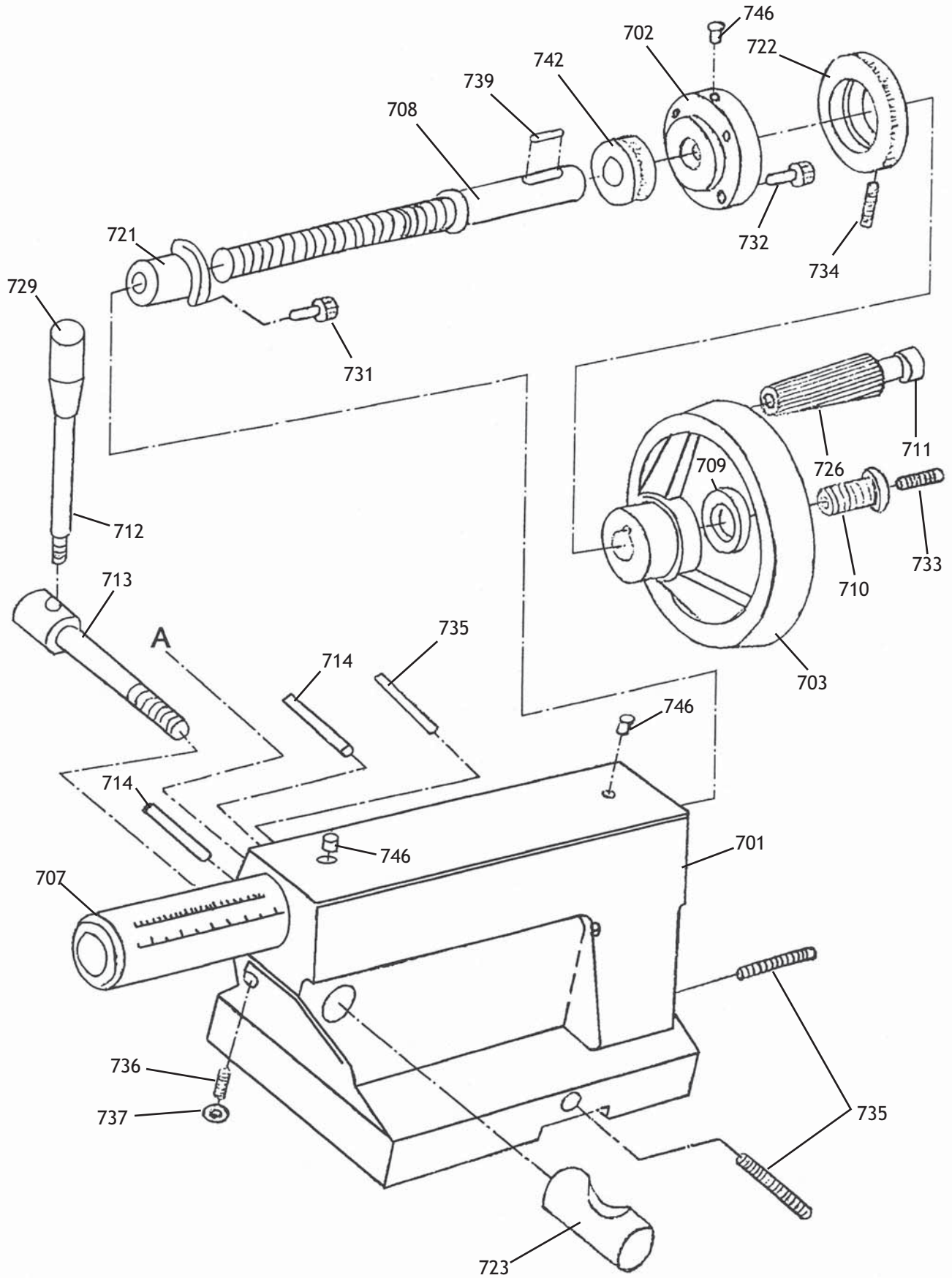

Tailstock Lock Assembly

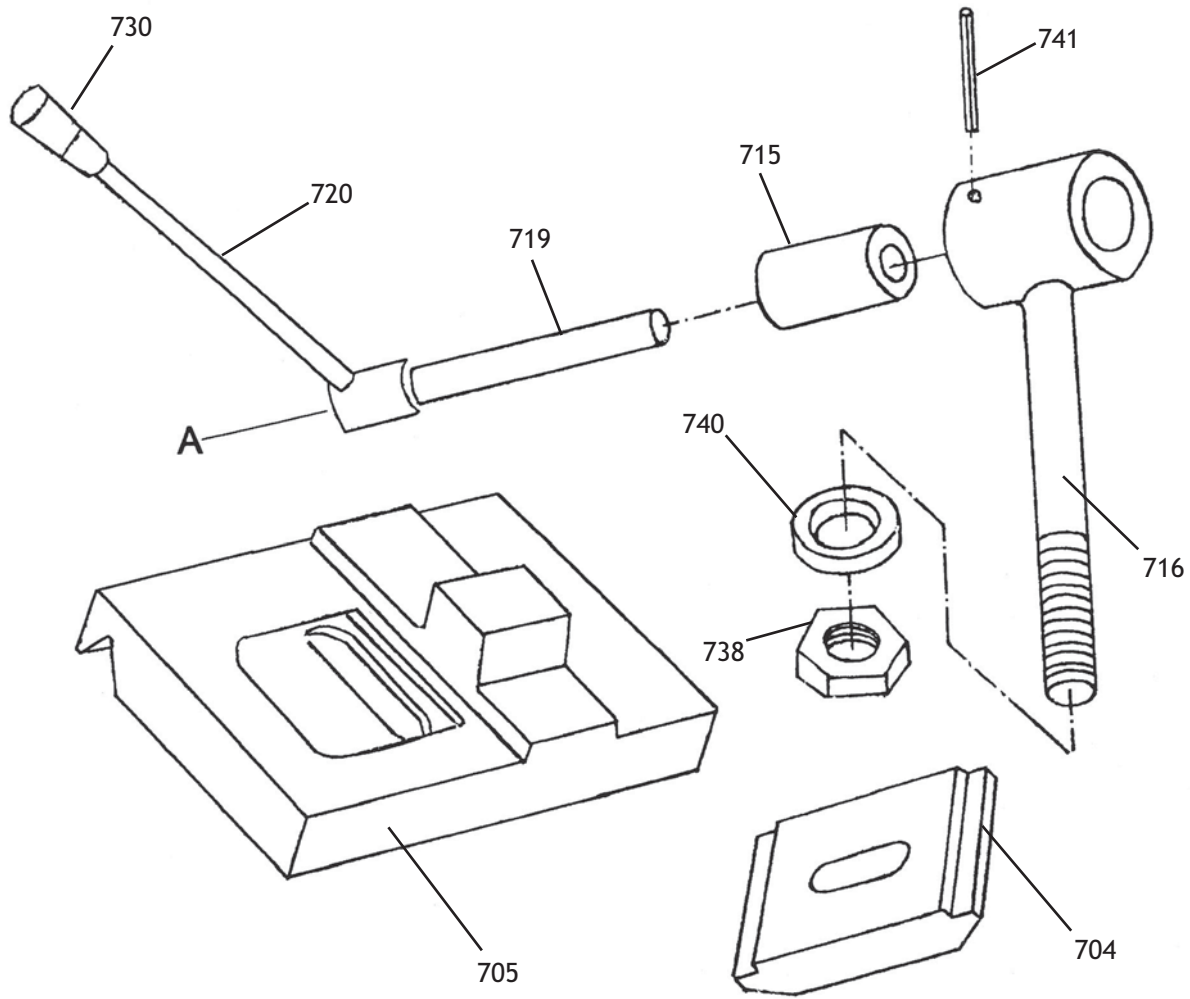

REF	PART #	DESCRIPTION
701	P4016701	TAILSTOCK CASTING
702	P4016702	FLANGE COVER
703	P4016703	HANDWHEEL
704	P4016704	CLAMP PLATE
705	P4016705	BASE
707	P4016707	QUILL
708	P4016708	LEADSCREW
709	PW03M	FLAT WASHER 6MM
710	P4016710	BTN HD CAP SCR M8-1.25 X 28
711	P4016711	SPECIAL SCREW M8-1.25 X 32
712	P4016712	HANDLE SHAFT
713	P4016713	LOCKING SHAFT
714	P4016714	THREADED STOP PIN M8-1.25
715	P4016715	COLLAR
716	P4016716	CAMSHAFT
719	P4016719	SHAFT
720	P4016720	LEVER
721	P4016721	LEADSCREW NUT
722	P4016722	INDEX RING

REF	PART #	DESCRIPTION
723	P4016723	PIVOT BLOCK
726	P4016726	HANDLE
729	P4016729	KNOB M8-1.25 X 40
730	P4016730	KNOB M10-1.5 X 50
731	PSB17M	CAP SCREW M4-.7 X 10
732	PSB01M	CAP SCREW M6-1 x 16
733	PSS57M	SET SCREW M5-.8 X 20
734	PSS01M	SET SCREW M6-1 X 10
735	PSS86M	SET SCREW M10-1.5 X 45
736	PSS74M	SET SCREW M8-1.25 X 35
737	PN03M	HEX NUT M8-1.25
738	PN09M	HEX NUT M12-1.75
739	PK47M	KEY 4 X 15
740	PW06M	FLAT WASHER 12MM
741	PRP06M	ROLL PIN 5 X 24
742	P8102	THRUST BEARING 8102
746	P4016746	OILER 8MM
747	P4016747	COMPLETE TAILSTOCK ASSY



Follow and Steady Rest Assemblies

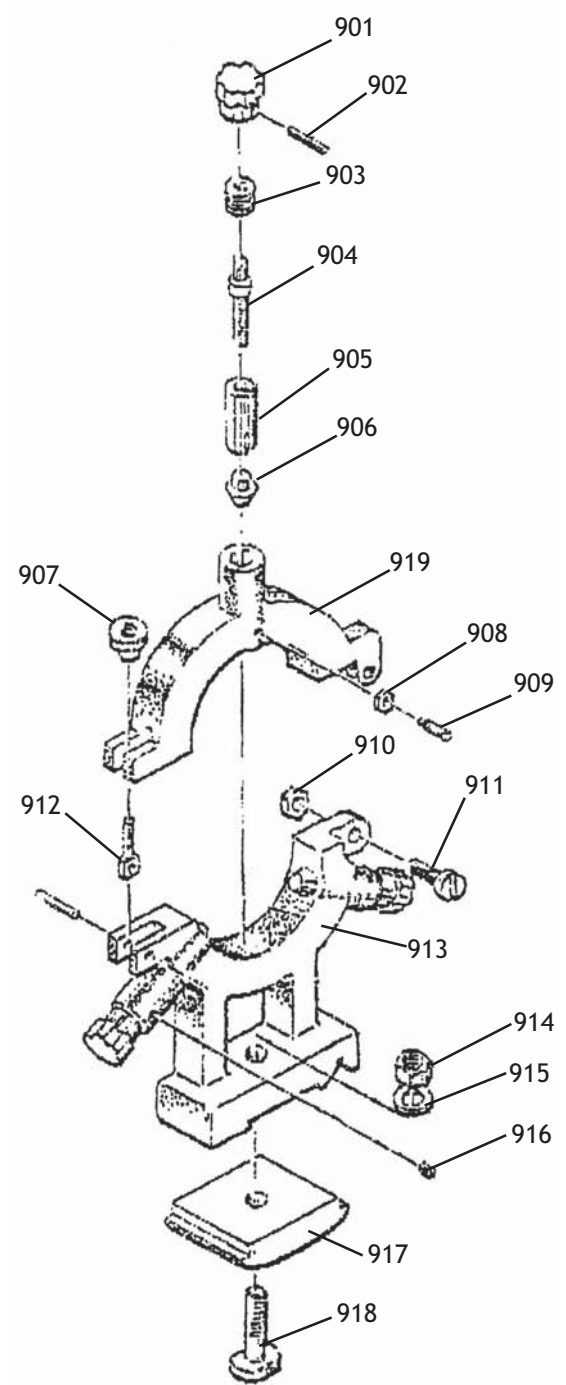
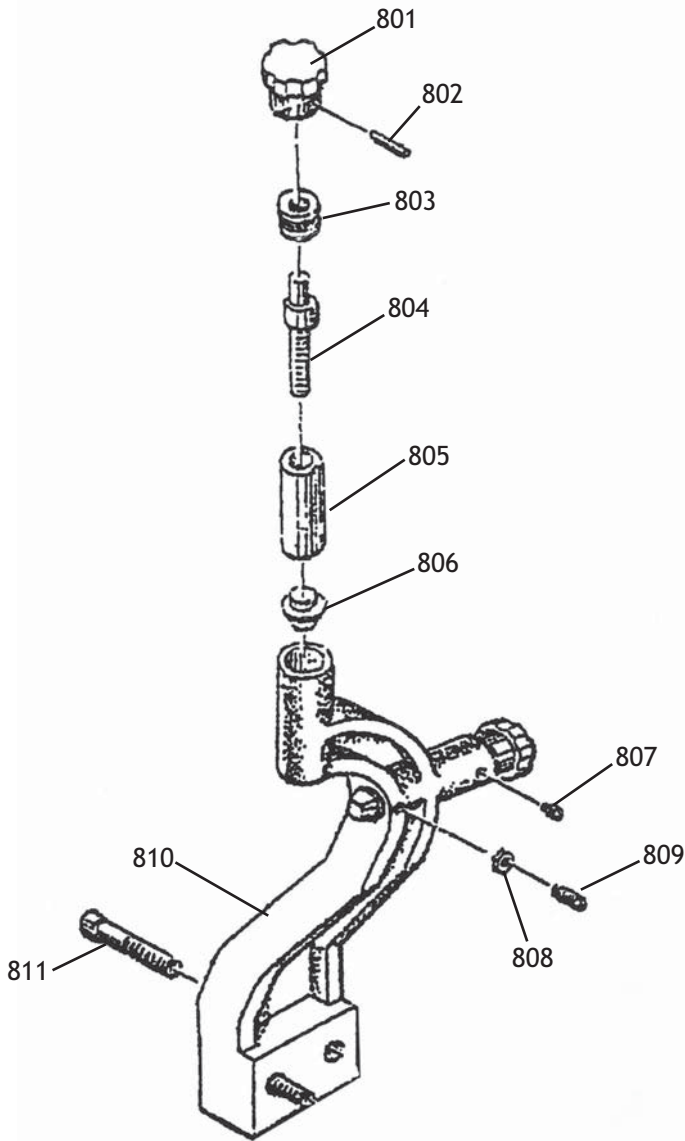

Electrical Components and Accessories

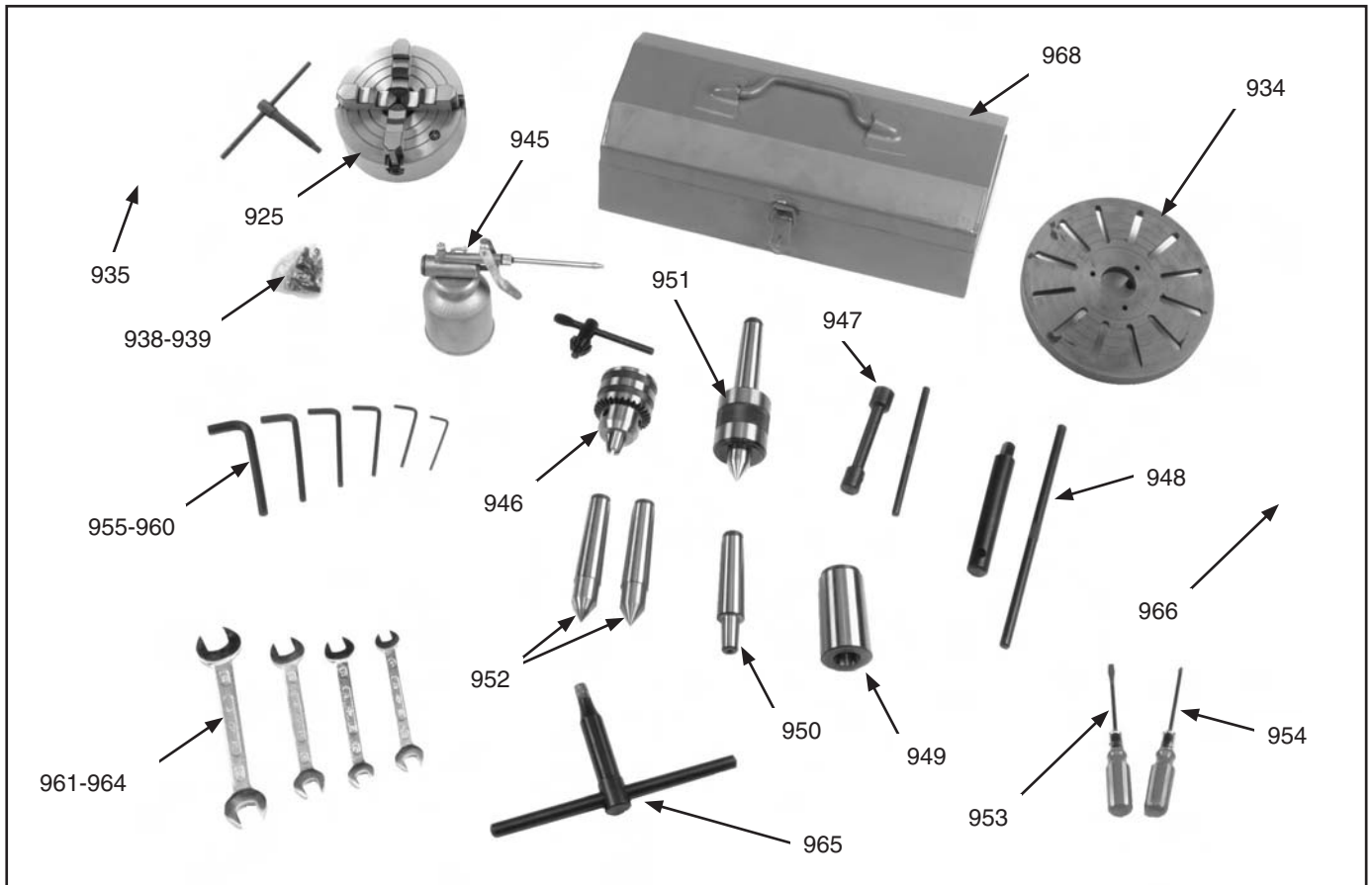

REF	PART #	DESCRIPTION
801	P4016801	KNOB-PINNED
802	PRP02M	ROLL PIN 3 X 16
803	P4016803	BUSHING
804	P4016804	SPECIAL SCREW
805	P4016805	SLEEVE
806	P4016806	BRASS FINGER
807	PSS02M	SET SCREW M6-1 X 6
808	PN01M	HEX NUT M6-1
809	PSS11M	SET SCREW M6-1 X 16
810	P4016810	BASE CASTING
811	PSB40M	CAP SCREW M8-1.25 X 35
812	P4016812	COMPLETE FOLLOW REST
900	P4016900	COMPLETE STEADY REST
901	P4016801	KNOB
902	PRP02M	ROLL PIN 3 X 16
903	P4016803	BUSHING
904	P4016804	SPECIAL SCREW
905	P4016805	SLEEVE
906	P4016806	BRASS FINGER
907	P4016807	LOCK KNOB
908	PN01M	HEX NUT M6-1
909	PSS11M	SET SCREW M6-1 X 16
910	PN01M	HEX NUT M6-1
911	PS62M	PHLP HD SCR M6-1 X 30
912	P4016912	PIVOT BOLT
913	P4016913	BASE CASTING
914	PN09M	HEX NUT M12-1.75
915	PW06M	FLAT WASHER 12MM
916	PSS02M	SET SCREW M6-1 X 6
917	P4016917	CLAMP PAD
918	P4016918	CLAMP SCREW
919	P4016919	TOP CASTING
922	P4016922	EMERGENCY STOP
923	P4016923	JOG BUTTON

REF	PART #	DESCRIPTION
924	P4016924	POWER ON LIGHT
925	P4016925	8" FOUR-JAW UNIVERSAL CHUCK WITH KEY
934	P4016934	12" FACE PLATE
935	P4016935	CHUCK 3 JAW
938	P4016938	D1-4 CHUCK STUDS
939	P4016939	SET SCREW FOR CAMLOCK STUDS
942	P4016942	TRANSFORMER JBK3-63
943	P4016943	CONTACTOR CJX2501D
944	P4016944	CONTACTOR JZC340D
945	P4016945	OILER
946	P4016946	DRILL CHUCK B16 WITH KEY
947	P4016947	WRENCH FOR TOOL POST WITH HANDLE
948	P4016948	LARGE CHUCK KEY WITH HANDLE
949	P4016949	SPINDLE SLEEVE ADAPTER
950	P4016950	DRILL CHUCK ARBOR B16 X MT3
951	P4016951	LIVE CENTER MT-3
952	P4016952	#3 MORSE TAPER DEAD CENTER
953	P4016953	FLAT HEAD SCREWDRIVER
954	P4016954	PHILLIPS SCREWDRIVER
955	PAW02.5M	HEX WRENCH 2.5MM
956	PAW03M	HEX WRENCH 3MM
957	PAW04M	HEX WRENCH 4MM
958	PAW05M	HEX WRENCH 5MM
959	PAW06M	HEX WRENCH 6MM
960	PAW06M8M	HEX WRENCH 8MM
961	PWR911	OPEN-END WRENCH 9/11MM
962	PWR1012	WRENCH 10 X 12
963	PWR1214	WRENCH 12 X 14
964	PWR1719	WRENCH 17 X 19
965	P4016965	CHUCK KEY (3-JAW & SPINDLE)
966	P4016966	BRASS DOWEL
967	P4016967	TERMINAL BAR
968	P4016968	TOOLBOX



Stand Components

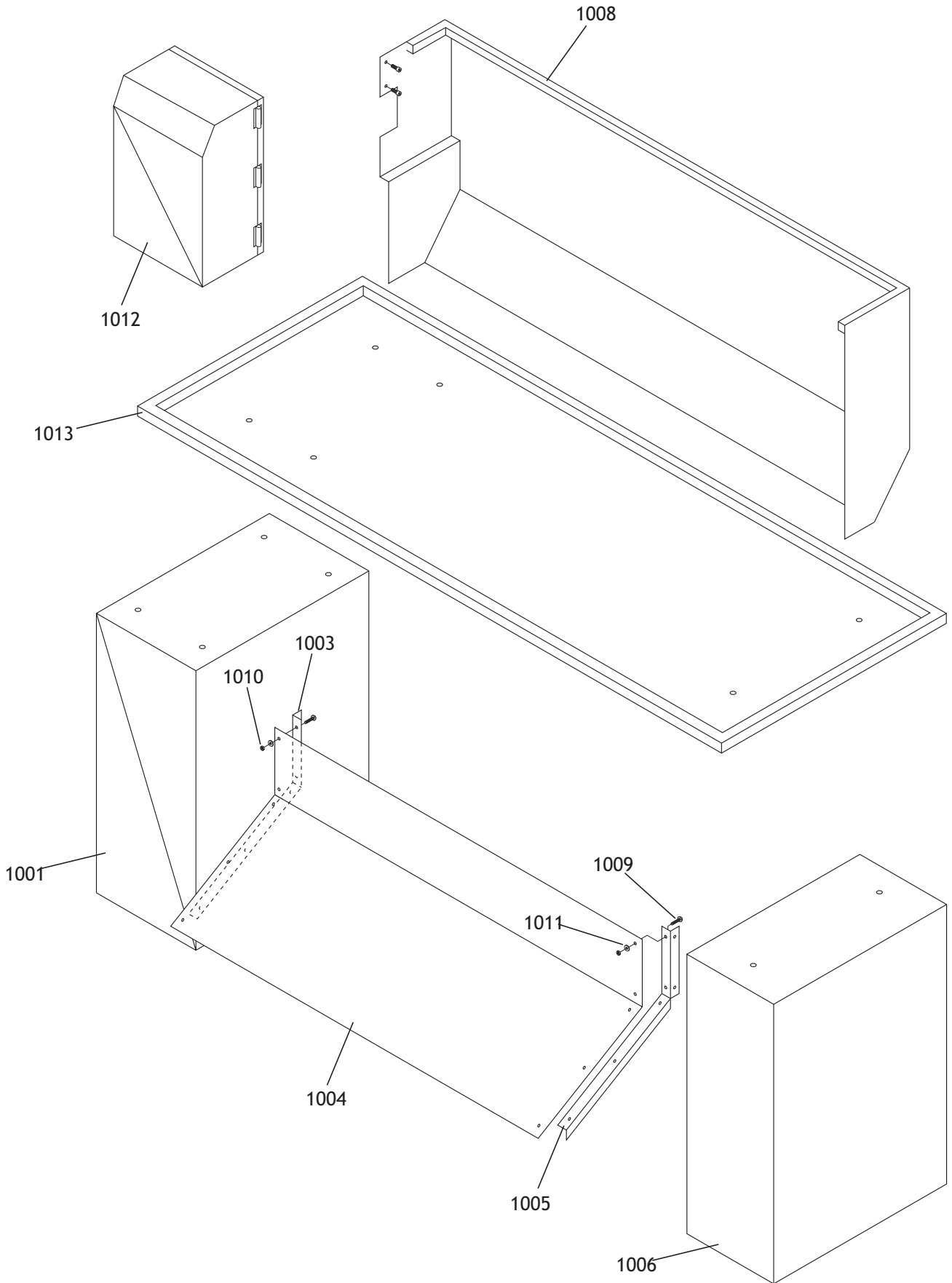

Safety Labels

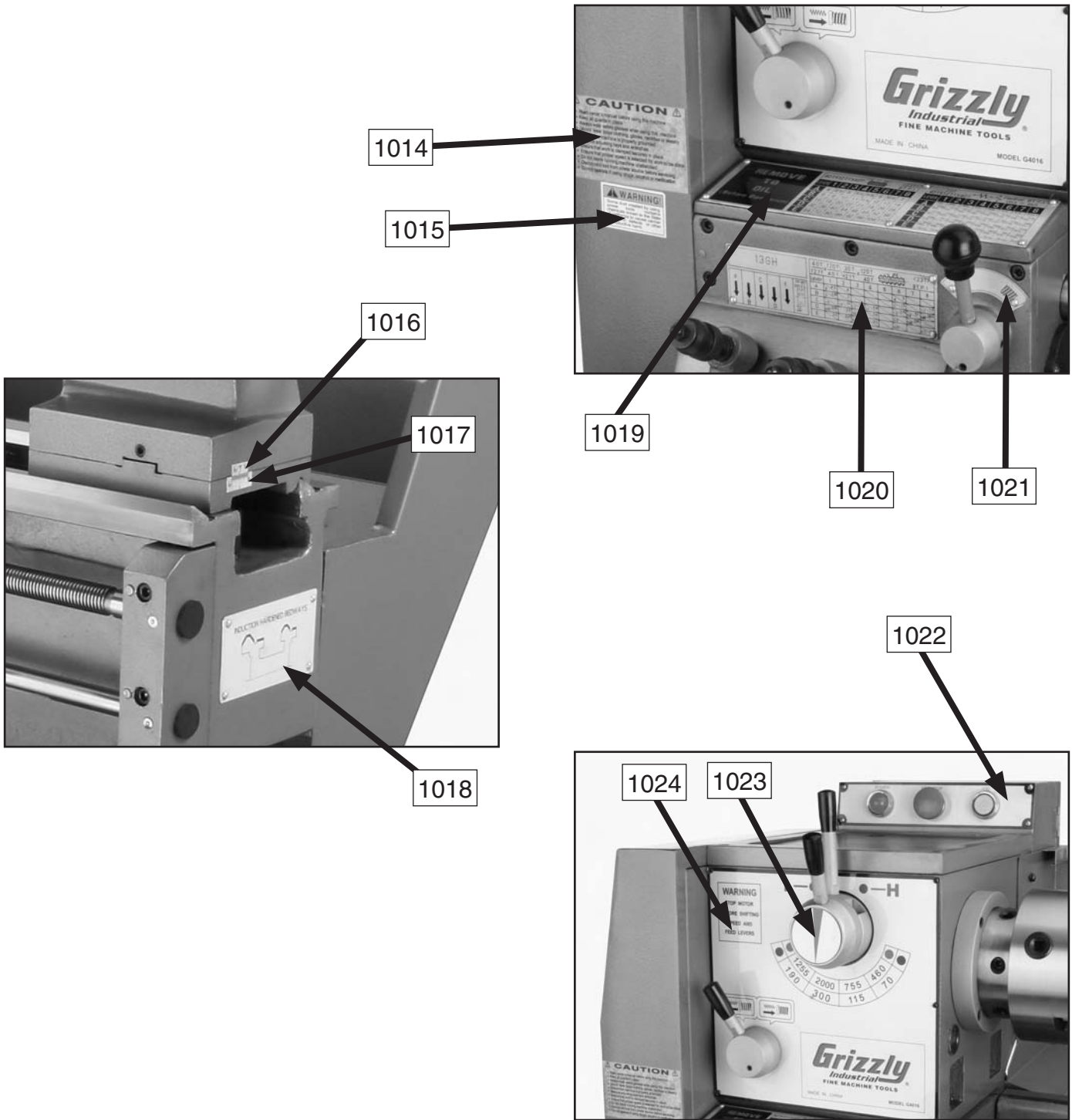

⚠️ WARNING

Safety labels warn about machine hazards and ways to prevent injury. The owner of this machine **MUST** maintain the original location and readability of the labels on the machine. If any label is removed or becomes unreadable, **REPLACE** that label before using the machine again. Contact Grizzly at (800) 523-4777 or www.grizzly.com to order new labels.



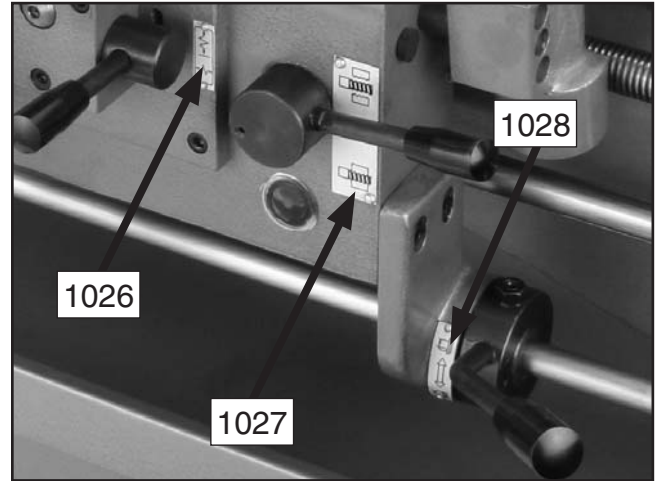
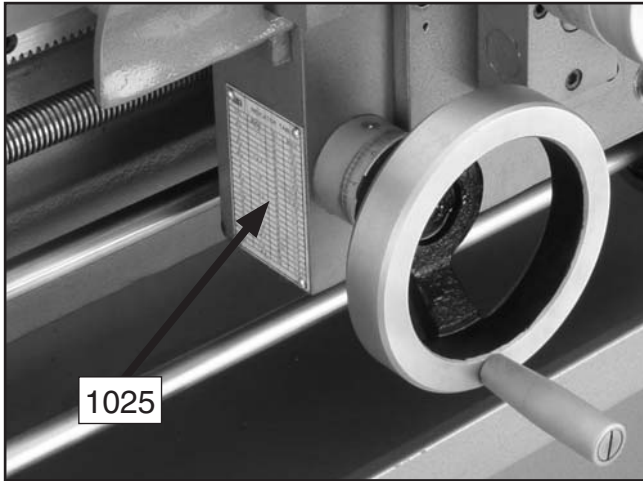

REF	PART #	DESCRIPTION
1001	P40161001	LEFT STAND
1003	P40161003	LEFT BRACE
1004	P40161004	CENTER PANEL
1005	P40161005	RIGHT BRACE
1006	P40161006	RIGHT STAND
1008	P40161008	BACKSPLASH
1009	PS68M	PHLP HD SCR M6-1 X 10
1010	PN01M	HEX NUT M6-1
1011	PLW03M	LOCK WASHER 6MM
1012	P40161012	ELECTRICAL BOX
1013	P40161013	CHIP TRAY
1014	P40161014	G4016 CAUTION LABEL
1015	P40161015	CALIFORNIA WARNING LABEL

REF	PART #	DESCRIPTION
1016	P40161016	UPPER OFFSET SCALE
1017	P40161017	LOWER OFFSET SCALE
1018	P40161018	INDUCTION HARDENED PLATE
1019	P40161019	FEED RATE CHART PLATE
1020	P40161020	METRIC THREAD CHART PLATE
1021	P40161021	LEADSCREW/FEEDROD PLATE
1022	P40161022	POWER PANEL PLATE
1023	P40161023	SPINDLE SPEED INDICATOR
1024	P40161024	HEADSTOCK LABEL PLATE
1025	P40161025	THREAD DIAL CHART PLATE
1026	P40161026	CROSS/LONGITUDINAL PLATE
1027	P40161027	HALF NUT PLATE
1028	P40161028	SPINDLE CONTROL PLATE



WARRANTY AND RETURNS

Grizzly Industrial, Inc. warrants every product it sells for a period of **1 year** to the original purchaser from the date of purchase. This warranty does not apply to defects due directly or indirectly to misuse, abuse, negligence, accidents, repairs or alterations or lack of maintenance. This is Grizzly's sole written warranty and any and all warranties that may be implied by law, including any merchantability or fitness, for any particular purpose, are hereby limited to the duration of this written warranty. We do not warrant or represent that the merchandise complies with the provisions of any law or acts unless the manufacturer so warrants. In no event shall Grizzly's liability under this warranty exceed the purchase price paid for the product and any legal actions brought against Grizzly shall be tried in the State of Washington, County of Whatcom.

We shall in no event be liable for death, injuries to persons or property or for incidental, contingent, special, or consequential damages arising from the use of our products.

To take advantage of this warranty, contact us by mail or phone and give us all the details. We will then issue you a "Return Number," which must be clearly posted on the outside as well as the inside of the carton. We will not accept any item back without this number. Proof of purchase must accompany the merchandise.

The manufacturers reserve the right to change specifications at any time because they constantly strive to achieve better quality equipment. We make every effort to ensure that our products meet high quality and durability standards and we hope you never need to use this warranty.

Please feel free to write or call us if you have any questions about the machine or the manual.

Thank you again for your business and continued support. We hope to serve you again soon.





WARRANTY CARD

Name _____
 Street _____
 City _____ State _____ Zip _____
 Phone # _____ Email _____ Invoice # _____
 Model # _____ Order # _____ Serial # _____

The following information is given on a voluntary basis. It will be used for marketing purposes to help us develop better products and services. **Of course, all information is strictly confidential.**

1. How did you learn about us?

Advertisement Friend Catalog
 Card Deck Website Other:

2. Which of the following magazines do you subscribe to?

<input type="checkbox"/> Cabinet Maker	<input type="checkbox"/> Popular Mechanics	<input type="checkbox"/> Today's Homeowner
<input type="checkbox"/> Family Handyman	<input type="checkbox"/> Popular Science	<input type="checkbox"/> Wood
<input type="checkbox"/> Hand Loader	<input type="checkbox"/> Popular Woodworking	<input type="checkbox"/> Wooden Boat
<input type="checkbox"/> Handy	<input type="checkbox"/> Practical Homeowner	<input type="checkbox"/> Woodshop News
<input type="checkbox"/> Home Shop Machinist	<input type="checkbox"/> Precision Shooter	<input type="checkbox"/> Woodsmith
<input type="checkbox"/> Journal of Light Cont.	<input type="checkbox"/> Projects in Metal	<input type="checkbox"/> Woodwork
<input type="checkbox"/> Live Steam	<input type="checkbox"/> RC Modeler	<input type="checkbox"/> Woodworker West
<input type="checkbox"/> Model Airplane News	<input type="checkbox"/> Rifle	<input type="checkbox"/> Woodworker's Journal
<input type="checkbox"/> Modeltec	<input type="checkbox"/> Shop Notes	<input type="checkbox"/> Other:
<input type="checkbox"/> Old House Journal	<input type="checkbox"/> Shotgun News	

3. What is your annual household income?

\$20,000-\$29,000 \$30,000-\$39,000 \$40,000-\$49,000
 \$50,000-\$59,000 \$60,000-\$69,000 \$70,000+

4. What is your age group?

20-29 30-39 40-49
 50-59 60-69 70+

5. How long have you been a woodworker/metalworker?

0-2 Years 2-8 Years 8-20 Years 20+ Years

6. How many of your machines or tools are Grizzly?

0-2 3-5 6-9 10+

7. Do you think your machine represents a good value?

Yes No

8. Would you recommend Grizzly Industrial to a friend?

Yes No

9. Would you allow us to use your name as a reference for Grizzly customers in your area?

Note: *We never use names more than 3 times.* Yes No

10. Comments: _____

CUT ALONG DOTTED LINE

FOLD ALONG DOTTED LINE



Place
Stamp
Here



GRIZZLY INDUSTRIAL, INC.
P.O. BOX 2069
BELLINGHAM, WA 98227-2069



FOLD ALONG DOTTED LINE

Send a Grizzly Catalog to a friend:

Name _____
Street _____
City _____ State _____ Zip _____

TAPE ALONG EDGES--PLEASE DO NOT STAPLE

grizzly.com

TOOL WEBSITE

Buy Direct and Save with Grizzly® – Trusted, Proven and a Great Value!

*Visit Our Website Today And Discover Why
Grizzly® Is The Industry Leader!*

- SECURE ORDERING
- ORDERS SHIPPED WITHIN 24 HOURS
- E-MAIL RESPONSE WITHIN ONE HOUR

-OR-

Call Today For A **FREE**
Full Color Catalog

1-800-523-4777

