

# INSTRUCTIONS FOR G2320 AND G2606 MOULDING HEAD

## ⚠️ WARNING

- Failure to follow these guidelines will result in serious personal injury.
- ALWAYS WEAR ANSI APPROVED EYE AND EAR PROTECTION when using this cutter.
- Never use on 1/2" spindle.
- Never operate with only one moulding knife installed.
- Never feed lumber with the rotation of the cutter.
- Follow the safety guidelines set forth by the manufacturer of the shaper.

# Grizzly

Industrial, Inc. ®

## ⚠️ CAUTION

The moulding cutters have sharp edges. Use care while removing them from the package. The oily film must be removed from the knives before installation to help insure secured assembly.

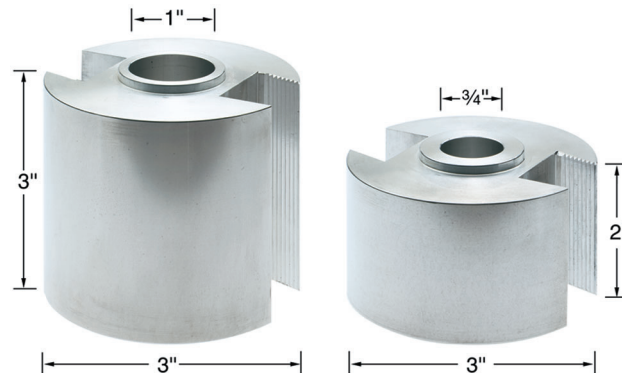

The 2-knife moulding head is designed to be used on a vertical spindle shaper. It is made of the highest quality aircraft aluminum and machined to exact tolerances. The moulding head accepts matched pairs of interchangeable corrugated backed High Speed knives (not included). The moulding head will use either 60° or 90° cut corrugations that are spaced 1/16" apart. The knives lock into position by wedge-type gibs for maximum safety.

Do not use this moulding head on any machine other than one equipped with a 3/4" spindle for the G2320 or 1" spindle for the G2606. The shaper should have at least a 1 1/2 H.P. motor. We also recommend the use of a power feeder when using this moulding head.

NOTE: These instructions and drawings are intended for explanation and clarification purposes only as they pertain to the moulding head. You must apply all safety measures as they relate to shaping operations and your specific equipment. Review and apply all safety measures before you use this moulding head.

## ⚠️ WARNING

- Unplug shaper before installing or adjusting cutter.
- Keep all guards and anti-kick-back devices in place.
- Double check cutterhead to insure it is tight and secure in spindle.
- Always inspect lumber and other wood materials for cracks, knots, or other imperfections that could cause lumber to kick or shatter while shaping.

### STEP 1 — INSTALLING THE FIRST KNIFE

1. Hold a gib in the moulding head and slide the knife into place along the corrugations. Make sure all of the corrugations in the moulding head engage the knife. **See illustration to the right.**
2. Slide the knife into the moulding head until it is centered along the body of the cutterhead.
3. While holding the position of the knife and gib in the moulding head, tighten the gib with a 3/16" Allen® wrench. **Do not over-tighten the setscrews. Use only enough force to secure the knife snugly in position.**

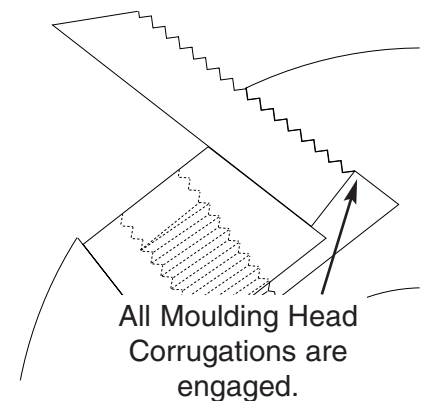

## STEP 2 —INSTALLING THE SECOND KNIFE

1. Insert the second knife in the moulding head as in **Step 1**.
2. Take care to match the number of corrugations which are engaged on the second knife so it is the same position as the first knife. This will ensure that both knives will be set to the same height.
3. Do not completely secure knife at this time. Tighten gib so the knife is held in position. Proceed to next step.

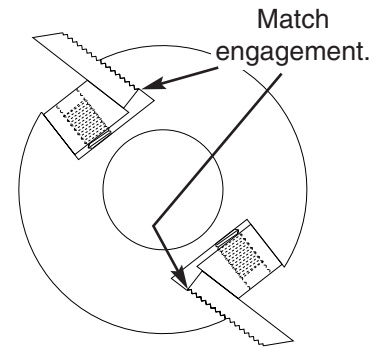

### **WARNING**

Make sure both knives are held securely in position. Recheck all adjustments and tightening sequences. Failure to do so may create a serious safety hazard.

## STEP 3 — KNIFE ADJUSTMENT

**Disconnect electrical power from shaper.** Install cutterhead onto spindle and fasten as detailed in the shaper's manual. Choose a reference point on the first knife installed and adjust spindle height until this point is even with table top. (The reference point can be the bottom corner of the knife or any feature that allows vertical alignment with the table top). Adjust the second knife up or down until the corresponding point is at the same height with respect to the table. Now snug up the second gib. At this time, tighten all the setscrews in both gibs. Tighten each setscrew a small amount, then move to the next setscrew until they all are tight. **Do not** over-tighten gib screws.

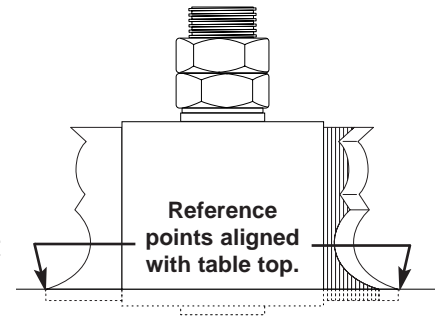

## SPINDLE MOUNTING TIPS

- Mount the moulding head as low as possible on the spindle.
- Add a spacer(s) on top of cutterhead to ensure that the spindle nut does not rest on the cutterhead shoulder.
- Secure the assembly with a locking washer and nut or two nuts locked together.
- Ensure that your shaper is in tip-top running condition and that all guards are in place.

## GENERAL PROCEDURES

The wide selection of knife profiles make the moulding head a versatile addition to your shaper. The moulding head operates on the same principle as other shaper cutters and can be used for straight edge shaping as well as irregular shaping. Since the moulding head is larger in diameter than most cutters, it must be operated at speeds ranging between 4,000 to 7,000 RPM. Please refer to your shaper's manual if you are unsure about operating speeds. **Always** feed stock against rotation. Cutterhead must come to a complete stop and the shaper must be disconnect from power supply before making inspections or adjustments.

## STRAIGHT EDGE SHAPING

Remember, when setting up for either straight edge or irregular edge shaping, the **electrical power must be disconnected**. For straight edge shaping use the fence assembly. See fence adjustment section in the shaper's manual to align fences. All guards must be in position and functioning correctly.

1. Select the appropriate knife profile and lock into moulding head (See Page 1). Secure moulding head onto spindle.
2. Check rotation. Be sure moulding head is rotating in the desired direction and that the knives are oriented correctly. **See illustration at right.**
3. Adjust spindle height.
4. Position the outfeed fence for depth of cut.
5. Use hold-downs, jigs or anti-kickback devices to secure workpiece during the shaping operation. See the shaper's manual for particular safety information regarding this shaping operation.
6. Always make a sample cut on a piece of scrap wood before shaping workpiece. Readjust if necessary.
7. Follow recommended operating procedures for shaping end of stock. See the shaper's manual for particular safety information regarding this shaping operation.

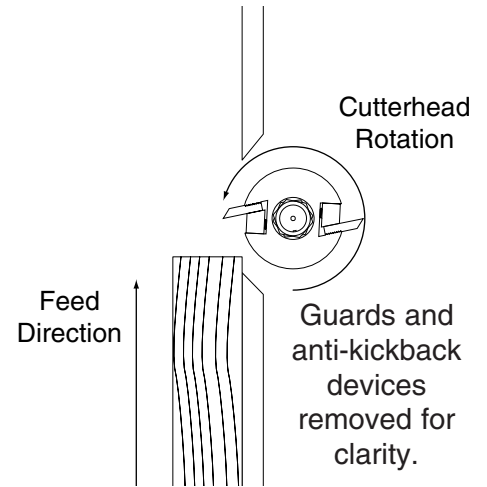

**Make sure cutterhead comes to a complete stop and the power is disconnected before making any inspections or adjustments.**

## IRREGULAR SHAPING

### **CAUTION**

Freehand work is one of the more hazardous milling operations accomplished on a shaper. Make sure you understand and follow all safety procedures for freehand work. All guards must be in position and functioning correctly.

Irregular shaping (freehand) takes a high degree of skill and manual dexterity to perform. The fence assembly is not used in irregular shaping and should be removed. Rub collars must be used. Choose the correct diameter for the appropriate depth of cut. When doing freehand work, a starting pin must be used. The purpose of the starting pin is to support the work piece. The starting pin acts as a pivot point and gives the operator more control during the beginning of the cut.

Rub collars can be positioned on top or below the moulding head, depending on the type of work. Plan ahead and determine which rub collar position will work best for your particular needs.

1. **Disconnect power to the shaper.**
2. Remove the fence assembly.
3. Choose the appropriate knives and fasten onto spindle along with the rub collar. See knife installation section.
4. Check direction of rotation.

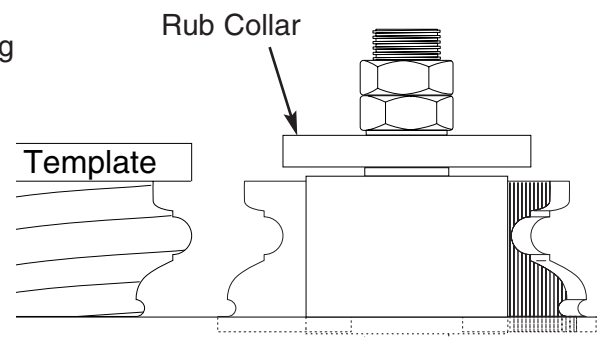

5. Lock spindle height after aligning cutter to workpiece.

6. Insert guide pin into table surface; choose appropriate hole position. See owner's manual for location. If a starting pin is not available, use a starting block.

**⚠ WARNING**

- Always use a starting pin/block and rub collar for freehand work.
- Use guards and hold-downs.
- Follow the safety guidelines set forth by the manufacturer of the shaper.

7. Inspect stock or pattern for any irregularities which may cause a miss-cut.

8. Use some type of hold-down(s), fixtures and guards when performing freehand work.

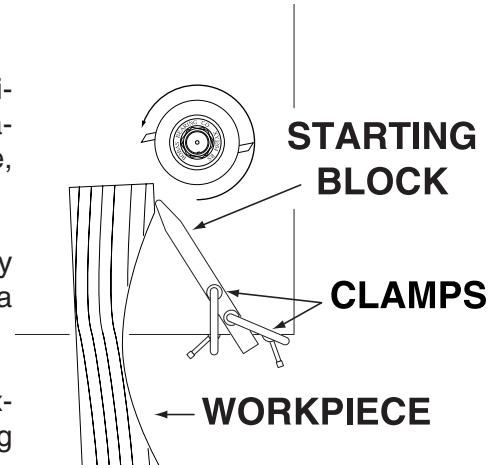

9. The workpiece should be placed in the starting position (1) using the guide pin for support, as shown below. Gradually swing the work into the cutter keeping the work piece against the starting pin (2).

10. After the workpiece is supported by the rub collar, swing the work free of the starting pin (3). Always feed against the rotation of the cutter.

11. Always make a sample cut on a piece of scrap wood. Readjust if necessary.

**Make sure cutterhead comes to a complete stop and the power is disconnected before making any inspections or adjustments.**

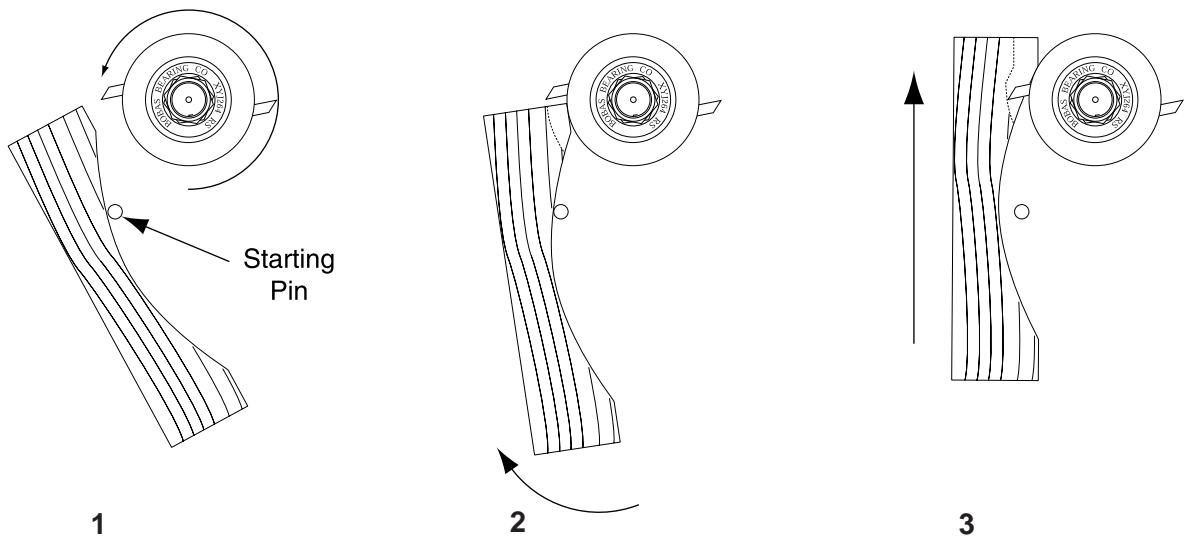

**Guards removed for illustration.**