

# *Grizzly* *Industrial, Inc.*®

## **G1023SL Series 10" LEFT-TILTING TABLE SAW OWNER'S MANUAL**

*COVERS G1023SL, G1023SLX, G1023SLW, G1023SLWX, G1023SLWX3*



COPYRIGHT © MARCH, 2006 BY GRIZZLY INDUSTRIAL, INC.  
**WARNING: NO PORTION OF THIS MANUAL MAY BE REPRODUCED IN ANY SHAPE  
OR FORM WITHOUT THE WRITTEN APPROVAL OF GRIZZLY INDUSTRIAL, INC.**

#TR8016 PRINTED IN TAIWAN

# **WARNING!**

**This manual provides critical safety instructions on the proper setup, operation, maintenance and service of this machine/equipment.**

**Failure to read, understand and follow the instructions given in this manual may result in serious personal injury, including amputation, electrocution or death.**

**The owner of this machine/equipment is solely responsible for its safe use. This responsibility includes but is not limited to proper installation in a safe environment, personnel training and usage authorization, proper inspection and maintenance, manual availability and comprehension, application of safety devices, blade/cutter integrity, and the usage of personal protective equipment.**

**The manufacturer will not be held liable for injury or property damage from negligence, improper training, machine modifications or misuse.**

# **WARNING!**

**Some dust created by power sanding, sawing, grinding, drilling, and other construction activities contains chemicals known to the State of California to cause cancer, birth defects or other reproductive harm. Some examples of these chemicals are:**

- **Lead from lead-based paints.**
- **Crystalline silica from bricks, cement and other masonry products.**
- **Arsenic and chromium from chemically-treated lumber.**

**Your risk from these exposures varies, depending on how often you do this type of work. To reduce your exposure to these chemicals: Work in a well ventilated area, and work with approved safety equipment, such as those dust masks that are specially designed to filter out microscopic particles.**

# Table of Contents

<b>INTRODUCTION</b> .....	<b>3</b>
Foreword .....	3
Contact Info.....	3
Machine Data Sheet.....	4
Identification .....	5
<b>SECTION 1: SAFETY</b> .....	<b>6</b>
Safety Instructions for Machinery.....	6
Additional Safety Instructions for Table Saws .....	8
Preventing Kickback.....	9
Protecting Yourself From Kickback.....	9
Glossary of Terms.....	10
<b>SECTION 2: CIRCUIT REQUIREMENTS</b> .....	<b>11</b>
Operation.....	11
Grounding.....	12
Extension Cords.....	12
<b>SECTION 3: SET UP</b> .....	<b>13</b>
Set Up Safety .....	13
Items Needed for Set Up .....	13
Unpacking .....	13
Hardware Recognition Chart.....	14
Machine Inventory.....	15
Fence Inventory .....	16
G1023SL, W, WX, WX3.....	16
Fence Inventory .....	16
G1023SLX.....	16
Router Table Inventory.....	17
Clean Up .....	17
Site Considerations .....	18
Motor Brace.....	18
Tables.....	19
Switch.....	20
Fence .....	20
Router Table & Legs G1023SLW, WX, WX3.....	20
Extension Table & Legs G1023SLX .....	21
Motor Cover .....	22
Dust Port .....	22
Handwheel Lock Knob & Handle .....	22
Table Insert .....	23
Saw Blade .....	23
Guard Bracket.....	24
Blade Guard/Splitter.....	24
Pre-Run Check.....	27
Test Run.....	27

<b>SECTION 4: OPERATIONS .....</b>	<b>28</b>
Basic Controls .....	28
Mounting Router.....	29
G1023SLW, WX, WX3 .....	29
Blade Selection .....	29
Non-Through and Through Cuts .....	31
Ripping .....	31
Crosscutting .....	32
Miter Cuts.....	33
Blade Tilt/Bevel Cuts.....	33
Dado Cutting .....	34
Rabbet Cutting .....	36
Resawing.....	38
<b>SECTION 5: ACCESSORIES.....</b>	<b>41</b>
<b>SECTION 6: MAINTENANCE .....</b>	<b>45</b>
Schedule .....	45
Cleaning .....	45
Lubrication.....	45
<b>SECTION 7: SERVICE .....</b>	<b>46</b>
Troubleshooting.....	46
Blade Tilt Stops .....	48
Miter Slot to Blade.....	49
Blade Alignment .....	51
Adjusting Fence .....	52
Miter Gauge .....	52
G1023SL, SLX, SLW Wiring .....	53
G1023SLWX Wiring .....	54
G1023SLWX3 Wiring .....	55
G1023SL (All) Main Parts .....	56
G1023SL (All) Main Parts .....	57
G1023SL (All) Arbor/Motor Parts .....	58
G1023SL (All) Arbor/Motor Parts .....	59
G1023SL (All) Miter Gauge & Blade Guard.....	60
G1023SL (All) Miter Gauge & Blade Guard.....	61
G1023SL (All) Fence.....	62
G1023SL, W, WX, WX3 Fence Rails.....	63
G1023SLX Fence Rails.....	64
G1023SLW, X, X3 Router Table & Legs Parts.....	65
<b>WARRANTY AND RETURNS .....</b>	<b>66</b>

# INTRODUCTION

---

---

## Foreword

---

---

We are proud to offer the G1023SL Series table saws. These machines are part of a growing Grizzly family of fine woodworking machinery. When used according to the guidelines set forth in this manual, you can expect years of trouble-free, enjoyable operation and proof of Grizzly's commitment to customer satisfaction.

We are pleased to provide this manual. It was written to guide you through assembly, review safety considerations, and cover general operating procedures. It represents our effort to produce the best documentation possible.

The specifications, drawings, and photographs illustrated in this manual represent the G1023SL Series table saws as supplied when the manual was prepared. However, owing to Grizzly's policy of continuous improvement, changes may be made at any time with no obligation on the part of Grizzly. For your convenience, we always keep current Grizzly manuals available on our website at **[www.grizzly.com](http://www.grizzly.com)**. Any updates to your machine will be reflected in these manuals as soon as they are complete. Visit our site often to check for the latest updates to this manual!

## Contact Info

---

---

If you have any comments regarding this manual, please write to us at the address below:

Grizzly Industrial, Inc.  
c/o Technical Documentation Manager  
P.O. Box 2069  
Bellingham, WA 98227-2069

We stand behind our machines. If you have any service questions or parts requests, please call or write us at the location listed below.

Grizzly Industrial, Inc.  
1203 Lycoming Mall Circle  
Muncy, PA 17756  
Phone: (570) 546-9663  
Fax: (800) 438-5901  
E-Mail: [techsupport@grizzly.com](mailto:techsupport@grizzly.com)  
Web Site: <http://www.grizzly.com>





# MACHINE DATA SHEET

Customer Service #: (570) 546-9663 • To Order Call: (800) 523-4777 • Fax #: (800) 438-5901

## MODEL G1023SL Series 10" LEFT-TILTING TABLE SAWS

Model Number	G1023SL	G1023SLX	G1023SLW	G1023SLWX	G1023SLWX3
Motor	3 HP	3 HP	3 HP	5 HP	5 HP
Voltage	220V	220V	220V	220V	220V/440V
Phase	Single-Phase	Single-Phase	Single-Phase	Single-Phase	3-Phase
Amps	18	18	18	25	15/7.5
Speed	3450 RPM	3450 RPM	3450 RPM	3450 RPM	3450 RPM
Table Size (full assembly)	40 $\frac{1}{8}$ " x 27"	84 $\frac{1}{8}$ " x 27"	48" x 27"	48" x 27"	48" x 27"
Table Height	34"	34"	34"	34"	34"
Overall Machine Size	56"L x 34"W	84"L x 34"W	56"L x 34"W	56"L x 34"W	56"L x 34"W
Footprint Size	20 $\frac{1}{2}$ "L x 20 $\frac{1}{2}$ "W	20 $\frac{1}{2}$ "L x 20 $\frac{1}{2}$ "W	20 $\frac{1}{2}$ "L x 20 $\frac{1}{2}$ "W	20 $\frac{1}{2}$ "L x 20 $\frac{1}{2}$ "W	20 $\frac{1}{2}$ "L x 20 $\frac{1}{2}$ "W
Weight	410 lbs.	500 lbs.	430 lbs.	430 lbs.	430 lbs.
Fence	Shop Fox Classic	Shop Fox Classic	Shop Fox Classic	Shop Fox Classic	Shop Fox Classic
Router Table Ext Wing	No	No	Yes	Yes	Yes
Maximum Rip Right of Blade	26"	52"	26"	26"	26"
Maximum Rip Left of Blade	8"	8"	8"	8"	8"
Maximum Depth of Cut at 90°	3"	3"	3"	3"	3"
Maximum Depth of Cut at 45°	2 $\frac{1}{8}$ "	2 $\frac{1}{8}$ "	2 $\frac{1}{8}$ "	2 $\frac{1}{8}$ "	2 $\frac{1}{8}$ "
Maximum Blade Diameter	10"	10"	10"	10"	10"
Arbor Size	$\frac{5}{8}$ "	$\frac{5}{8}$ "	$\frac{5}{8}$ "	$\frac{5}{8}$ "	$\frac{5}{8}$ "
Arbor Speed	4200 RPM	4200 RPM	4200 RPM	4200 RPM	4200 RPM
Rim Speed	11,000 FPM	11,000 FPM	11,000 FPM	11,000 FPM	11,000 FPM
Blade Tilt (Left)	0° – 45°	0° – 45°	0° – 45°	0° – 45°	0° – 45°
Maximum Dado Width	$\frac{13}{16}$ "	$\frac{13}{16}$ "	$\frac{13}{16}$ "	$\frac{13}{16}$ "	$\frac{13}{16}$ "
Miter Slot Size	$\frac{3}{4}$ "W x $\frac{3}{8}$ "H	$\frac{3}{4}$ "W x $\frac{3}{8}$ "H	$\frac{3}{4}$ "W x $\frac{3}{8}$ "H	$\frac{3}{4}$ "W x $\frac{3}{8}$ "H	$\frac{3}{4}$ "W x $\frac{3}{8}$ "H
Dust Port Size	4"	4"	4"	4"	4"
Country of Origin	Taiwan	Taiwan	Taiwan	Taiwan	Taiwan
Assembly Time (approx.)	60 Minutes	90 Minutes	75 Minutes	75 Minutes	75 Minutes
Warranty	1 Year	1 Year	1 Year	1 Year	1 Year

REVISED 2/2006



# Identification

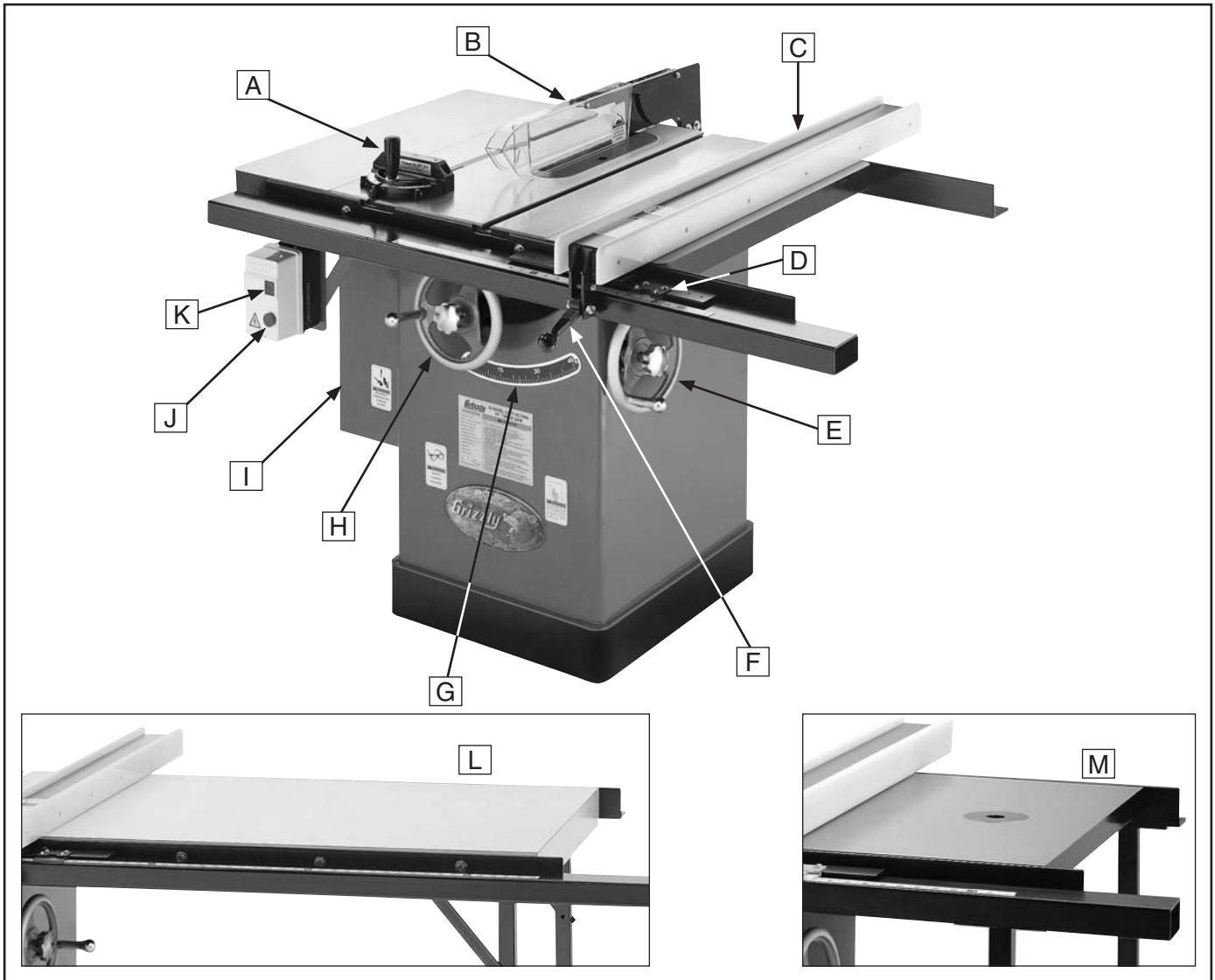

- A. Miter Gauge
- B. Blade Guard and Splitter
- C. Rip Fence (Shop Fox Classic)
- D. Fence Scale Indicator
- E. Blade Tilt Handwheel & Lock
- F. Fence Lock Handle
- G. Blade Tilt Scale
- H. Blade Height Handwheel

- I. Motor Cover
- J. STOP Button
- K. ON Button
- L. Extension Table & Rails  
(G1023SLX only)
- M. Router Table Extension Wing  
(G1023SLW models only)



# SECTION 1: SAFETY

## WARNING

### For Your Own Safety, Read Instruction Manual Before Operating this Machine

The purpose of safety symbols is to attract your attention to possible hazardous conditions. This manual uses a series of symbols and signal words which are intended to convey the level of importance of the safety messages. The progression of symbols is described below. Remember that safety messages by themselves do not eliminate danger and are not a substitute for proper accident prevention measures.

 **DANGER** Indicates an imminently hazardous situation which, if not avoided, WILL result in death or serious injury.

 **WARNING** Indicates a potentially hazardous situation which, if not avoided, COULD result in death or serious injury.

 **CAUTION** Indicates a potentially hazardous situation which, if not avoided, MAY result in minor or moderate injury. It may also be used to alert against unsafe practices.

**NOTICE** This symbol is used to alert the user to useful information about proper operation of the machine.

## WARNING

### Safety Instructions for Machinery

- 1. READ THROUGH THE ENTIRE MANUAL BEFORE STARTING MACHINERY.** Machinery presents serious injury hazards to untrained users.
- 2. ALWAYS USE ANSI APPROVED SAFETY GLASSES WHEN OPERATING MACHINERY.** Everyday eyeglasses only have impact resistant lenses—they are NOT safety glasses.
- 3. ALWAYS WEAR A NIOSH APPROVED RESPIRATOR WHEN OPERATING MACHINERY THAT PRODUCES DUST.** Wood dust is a carcinogen and can cause cancer and severe respiratory illnesses.
- 4. ALWAYS USE HEARING PROTECTION WHEN OPERATING MACHINERY.** Machinery noise can cause permanent hearing damage.
- 5. WEAR PROPER APPAREL. DO NOT** wear loose clothing, gloves, neckties, rings, or jewelry which may get caught in moving parts. Wear protective hair covering to contain long hair and wear non-slip footwear.
- 6. NEVER OPERATE MACHINERY WHEN TIRED, OR UNDER THE INFLUENCE OF DRUGS OR ALCOHOL.** Be mentally alert at all times when running machinery.



# WARNING

## Safety Instructions for Machinery

7. **ONLY ALLOW TRAINED AND PROPERLY SUPERVISED PERSONNEL TO OPERATE MACHINERY.** Make sure operation instructions are safe and clearly understood.
8. **KEEP CHILDREN AND VISITORS AWAY.** Keep all children and visitors a safe distance from the work area.
9. **MAKE WORKSHOP CHILD PROOF.** Use padlocks, master switches, and remove start switch keys.
10. **NEVER LEAVE WHEN MACHINE IS RUNNING.** Turn power **OFF** and allow all moving parts to come to a complete stop before leaving machine unattended.
11. **DO NOT USE IN DANGEROUS ENVIRONMENTS.** DO NOT use machinery in damp, wet locations, or where any flammable or noxious fumes may exist.
12. **KEEP WORK AREA CLEAN AND WELL LIT.** Clutter and dark shadows may cause accidents.
13. **USE A GROUNDED EXTENSION CORD RATED FOR THE MACHINE AMPERAGE.** Undersized cords overheat and lose power. Replace extension cords if they become damaged. DO NOT use extension cords for 220V machinery.
14. **ALWAYS DISCONNECT FROM POWER SOURCE BEFORE SERVICING MACHINERY.** Make sure switch is in OFF position before reconnecting.
15. **MAINTAIN MACHINERY WITH CARE.** Keep blades sharp and clean for best and safest performance. Follow instructions for lubricating and changing accessories.
16. **MAKE SURE GUARDS ARE IN PLACE AND WORK CORRECTLY BEFORE USING MACHINERY.**
17. **REMOVE ADJUSTING KEYS AND WRENCHES.** Make a habit of checking for keys and adjusting wrenches before turning machinery **ON**.
18. **CHECK FOR DAMAGED PARTS BEFORE USING MACHINERY.** Check for binding and alignment of parts, broken parts, part mounting, loose bolts, and any other conditions that may affect machine operation. Repair or replace damaged parts.
19. **USE RECOMMENDED ACCESSORIES.** Refer to the instruction manual for recommended accessories. The use of improper accessories may cause risk of injury.
20. **DO NOT FORCE MACHINERY.** Work at the speed for which the machine or accessory was designed.
21. **SECURE WORKPIECE.** Use clamps or a vise to hold the workpiece when practical. A secured workpiece protects your hands and frees both hands to operate the machine.
22. **DO NOT OVERREACH.** Keep proper footing and balance at all times.
23. **MANY MACHINES WILL EJECT THE WORKPIECE TOWARD THE OPERATOR.** Know and avoid conditions that cause the workpiece to "kickback."
24. **ALWAYS LOCK MOBILE BASES (IF USED) BEFORE OPERATING MACHINERY.**
25. **BE AWARE THAT CERTAIN DUST MAY BE HAZARDOUS** to the respiratory systems of people and animals, especially fine dust. Make sure you know the hazards associated with the type of dust you will be exposed to and always wear a respirator approved for that type of dust.



## **WARNING**

# Additional Safety Instructions for Table Saws

- 1. THROUGH SAWING.** Always use blade guard, splitter and anti-kickback fingers on all "through-sawing" operations. Through-sawing operations are those when the blade cuts completely through the workpiece as in ripping or crosscutting.
- 2. KICKBACK.** Kickback is a dangerous event in which a workpiece is thrown back from the saw at a high rate of speed. If you do not have a complete understanding of how kickback occurs, or how to prevent it, **DO NOT** operate this table saw.
- 3. WORKPIECE CONTROL.** Always hold the work firmly against the fence/miter gauge **AND** the table when cutting.
- 4. NARROW STOCK.** Always use a push-stick for ripping narrow stock.
- 5. FREE HAND CUTS.** Never perform any operation "free-hand" which means using only your hands to support or guide the workpiece. Always use the fence/miter gauge to support and guide the work.
- 6. DANGER ZONE.** Never stand or have any part of your body in line with the path of the saw blade.
- 7. REACHING AROUND BLADE.** Never reach behind or over the blade with either hand while the saw is running. If kickback occurs, that hand may be pulled into the spinning blade.
- 8. MITER GAUGE.** Never use the miter gauge and rip fence at the same time or you will greatly increase chance of kickback.
- 9. STALLED BLADE.** Turn the saw **OFF** before trying to free a stalled blade.
- 10. WORKPIECE SUPPORT.** Provide adequate support to the rear and sides of the saw table for wide or long workpieces.
- 11. AWKWARD OPERATIONS.** Avoid awkward operations or positions that could cause your hand to slip into the blade.
- 12. EXPERIENCING DIFFICULTIES.** If at any time you are experiencing difficulties performing the intended operation, stop using the machine! Then ask a qualified expert how the operation should be performed.
- 13. BLADE HEIGHT.** Avoid cutting with the blade more than  $\frac{1}{4}$ " higher than the thickness of the workpiece.
- 14. DAMAGED BLADE.** Damaged or dropped blades may throw a tooth or fly apart. Promptly replace blades in this condition.
- 15. DADO AND RABBET OPERATIONS.** These cuts present specific danger because they must be performed with the blade guard removed. Be especially aware of your personal safety whenever operating saw with the guard removed, and always immediately replace the blade guard after these operations are complete.

## **WARNING**

Like all power tools, there is danger associated with table saws. Accidents are frequently caused by lack of familiarity or failure to pay attention. Use this tool with respect and caution to lessen the possibility of operator injury. If normal safety precautions are overlooked or ignored, serious personal injury may occur.

## **CAUTION**

No list of safety guidelines can be complete. Operating this machinery may require additional safety precautions specific to your shop environment. Failure to use reasonable caution while operating this machine could result in serious personal injury.



## **WARNING**

Statistics show that most common accidents among table saw users can be linked to kickback. Kickback is typically defined as the high-speed expulsion of stock from the table saw toward its operator. In addition to the danger of the operator or others in the area being struck by the flying stock, it is often the case that the operator's hands are pulled into the blade during the kickback.

## **Preventing Kickback**

**Below are tips to avoid the most common causes of kickback:**

- Only cut workpieces with at least one smooth and straight edge. DO NOT cut warped, cupped or twisted wood.
- Never attempt freehand cuts. If the workpiece is not fed parallel with the blade, a kickback will likely occur. Always use the rip fence or crosscut fence to support the workpiece.
- Make sure the splitter is aligned with the blade. A misaligned splitter can cause the workpiece to catch or bind, resulting in an increased chance of kickback. If you think that your splitter is not aligned with the blade, check it immediately!
- Take the time to check and adjust the rip fence parallel with the blade; otherwise, the chances of kickback are extreme.
- Use the splitter for all "through cuts." The splitter maintains the kerf in the workpiece, reducing the chance of kickback.
- Feed cuts through to completion. Anytime you stop feeding a workpiece in the middle of a cut, the chance of binding, resulting in kickback, is greatly increased.

## **Protecting Yourself From Kickback**

**Even if you know how to prevent kickback, it may still happen. Here are some tips to protect yourself if kickback DOES occur:**

- Stand to the side of the blade during every cut. If a kickback does occur, the thrown workpiece usually travels directly in front of the blade.
- Wear safety glasses or a face shield. In the event of a kickback, your eyes and face are the most vulnerable part of your body.
- Never, for any reason, place your hand behind the blade. Should kickback occur, your hand will be pulled into the blade.
- Use a push stick to keep your hands farther away from the moving blade. If a kickback occurs, the push stick will most likely take the damage that your hand would have received.
- Use featherboards or anti-kickback devices to prevent or slow down kickback.



# Glossary of Terms

---

The following is a list of common definitions, terms and phrases used throughout this manual as they relate to this table saw and woodworking in general. Become familiar with these terms before assembling, adjusting or operating this machine. Your safety is **VERY** important to us at Grizzly!

**Arbor:** Metal shaft extending from the drive mechanism, to which saw blade is mounted.

**Bevel Edge Cut:** Tilting the arbor and saw blade to an angle between 0° and 45° to cut a beveled edge onto a workpiece.

**Blade Guard:** Metal or plastic safety device that mounts over the saw blade. Its function is to prevent the operator from coming into contact with the saw blade.

**Crosscut:** Cutting operation in which the cross-cut fence is used to cut across the grain, or across the shortest width of the workpiece.

**Dado Blade:** Blade or set of blades that are used to cut grooves and rabbets.

**Dado Cut:** Cutting operation that uses a dado blade to cut a flat bottomed groove into the face of the workpiece.

**Featherboard:** Safety device used to keep the workpiece against the rip fence and against the table surface.

**Kerf:** The resulting cut or gap in the workpiece after the saw blade passes through during a cutting operation.

**Kickback:** An event in which the workpiece is propelled back towards the operator at a high rate of speed.

**Parallel:** Being an equal distance apart at every point along two given lines or planes. I.e. the rip fence face is parallel to the face of the saw blade.

**Non-Through Cut:** A sawing operation that requires the removal of the blade guard and splitter. Dado and rabbet cuts are considered Non-Through Cuts because the blade does not protrude above the top face of the wood stock. Always remember to re-install the blade guard and splitter after performing a non-through cut.

**Perpendicular:** Lines or planes that intersect and form right angles. I.e. the blade is perpendicular to the table surface.

**Push Stick:** Safety device used to push the workpiece through a cutting operation. Used most often when rip cutting thin workpieces.

**Rabbet:** Cutting operation that creates an L-shaped channel along the edge of the workpiece.

**Splitter:** Metal plate located behind the blade. It maintains the kerf opening in the wood when performing a cutting operation.

**Straightedge:** A tool used to check the flatness, parallelism, or consistency of a surface.

**Through Cut:** A sawing operation in which the workpiece is completely sawn through.

**Rip Cut:** Cutting operation in which the rip fence is used to cut with the grain, or across the widest width of the workpiece.



# SECTION 2: CIRCUIT REQUIREMENTS

## Operation

### **!WARNING**

Serious personal injury could occur if you connect the machine to the power source before you have completed the set up process. **DO NOT** connect the machine to the power source until instructed to do so.

### Amperage Draw

The motor for your machine may draw the following amps at maximum load.

G1023SL, SLX, SLW .....	18 Amps
G1023SLWX .....	25 Amps
G1023SLWX3 @ 220V .....	15 Amps
G1023SLWX3 @ 440V* .....	7.5 Amps

### Circuit Requirements

You **MUST** connect your machine to a grounded circuit that is rated for the amperage given below. Never replace a circuit breaker on an existing circuit with one of higher amperage without consulting a qualified electrician to ensure compliance with wiring codes. **If you are unsure about the wiring codes in your area or you plan to connect your machine to a shared circuit, consult a qualified electrician.**

G1023SL, SLX, SLW .....	20 Amps
G1023SLWX .....	30 Amps
G1023SLWX3 @ 220V .....	20 Amps
G1023SLWX3 @ 440V* .....	15 Amps

*\* To run on 440V, you must rewire the motor and replace the 220V magnetic switch assembly with the 440V magnetic switch assembly (Part #P1023SLWX3087S). Refer to the wiring diagram on Page 55 for wiring details.*

### Plug Type

The cord set enclosed does not have a plug as the style of plug you require will depend upon the type of service you currently have or plan to install. We recommend using the following plugs for your machine on a dedicated circuit only (see **Figures 1–4** for examples):

G1023SL, SLX, SLW .....	L6-20
G1023SLWX .....	L6-30
G1023SLWX3 @ 220V .....	L15-20
G1023SLWX3 @ 440V ...	Power Shut-Off Switch

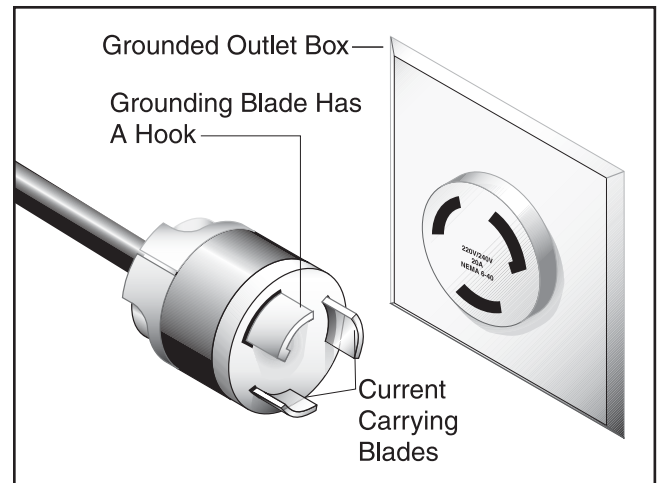

**Figure 1.** NEMA L6-20 plug and receptacle.

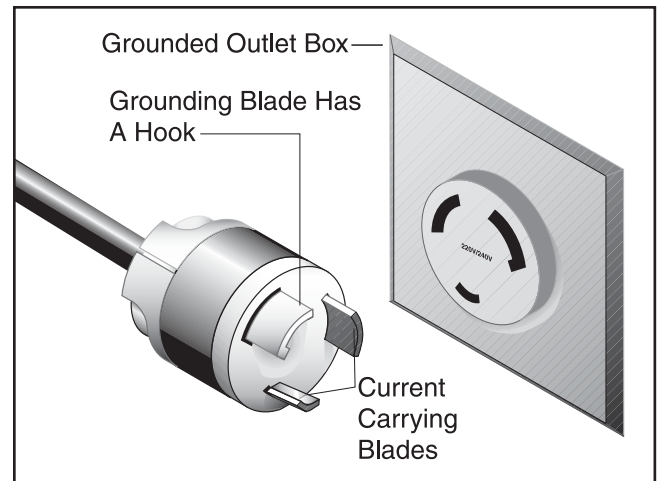

**Figure 2.** NEMA L6-30 plug and receptacle.



# Grounding

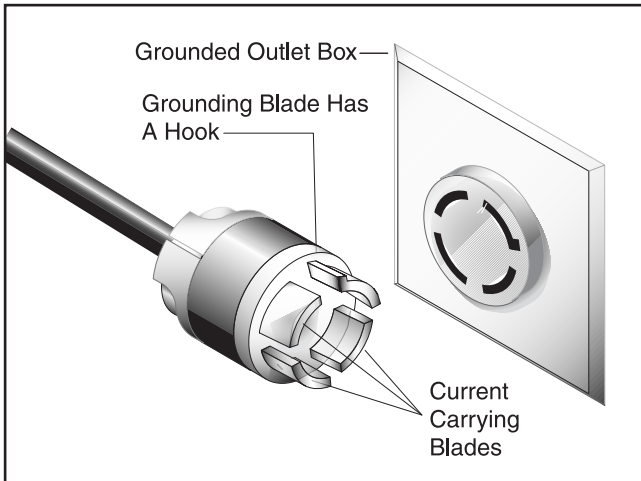

Figure 3. NEMA L15-20 plug and receptacle.

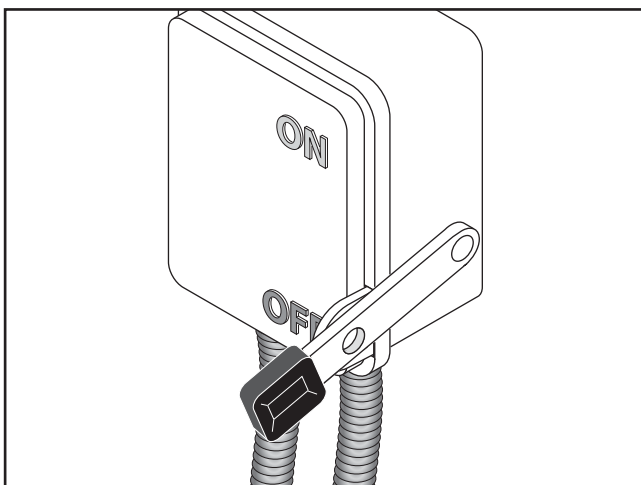
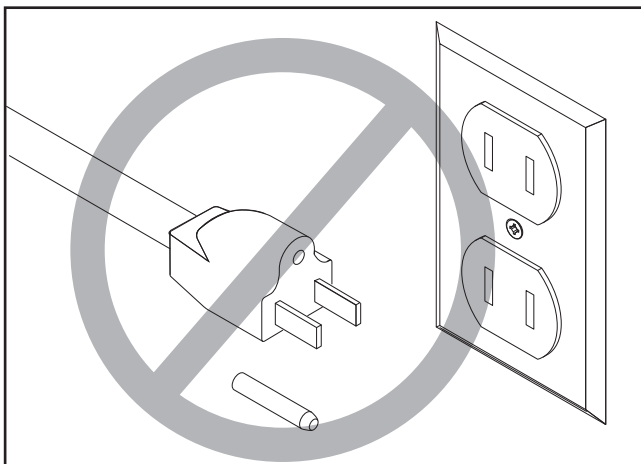

Figure 4. Power shut-off switch.



## **⚠ CAUTION**

This machine must have a ground prong in the plug to help ensure that it is grounded. **DO NOT** remove ground prong from plug to fit into a two-pronged outlet! If the plug will not fit the outlet, have the proper outlet installed by a qualified electrician.

In the event of an electrical short, grounding reduces the risk of electric shock. The grounding wire in the power cord must be properly connected to the grounding prong on the plug; likewise, the outlet must be properly installed and grounded. All electrical connections must be made in accordance with local codes and ordinances.

## Extension Cords

We do not recommend the use of extension cords. Instead, arrange the placement of your equipment and the installed wiring to eliminate the need for extension cords.

If you find it absolutely necessary to use an extension cord with your machine, the extension cord must also contain a ground wire and plug pin.

### 220V Operation

Use at least a 10 gauge cord that does not exceed 50 feet in length!

### 440V Operation

Do not use an extension cord with 440V!



# SECTION 3: SET UP

## Set Up Safety

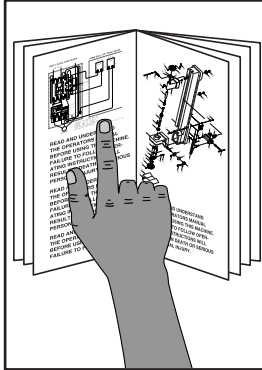

**! WARNING**  
This machine presents serious injury hazards to untrained users. Read through this entire manual to become familiar with the controls and operations before starting the machine!



**! WARNING**  
Wear safety glasses during the entire set up process!



**! WARNING**  
The G1023SL Series is a heavy machine. DO NOT over-exert yourself while unpacking or moving your machine—get assistance.

## Items Needed for Set Up

The following items are needed to complete the set up process, but are not included with your machine:

Description	Qty
• Safety Glasses (for each person) .....	1
• Degreaser or Solvent .....	Varies
• Phillips Head Screwdriver .....	1
• Wrench/Socket 8mm .....	1
• Wrench/Socket 10mm .....	1
• Wrench/Socket 12mm .....	1
• Wrench/Socket 14mm .....	1
• Wrench/Socket 9/16" .....	1
• Wrench/Socket 3/4" .....	1
• Utility Knife or Razor Blade .....	1
• Masking Tape .....	Varies
• Straightedge .....	1
• High Quality Square .....	1
• Hammer .....	1

## Unpacking

The G1023SL Series was carefully packed when it left our warehouse. If you discover the machine is damaged after you have signed for delivery, *please immediately call Customer Service at (570) 546-9663 for advice.*

Save the containers and all packing materials for possible inspection by the carrier or its agent. *Otherwise, filing a freight claim can be difficult.*

When you are completely satisfied with the condition of your shipment, you should inventory the contents.



# Hardware Recognition Chart

USE THIS CHART TO MATCH UP  
HARDWARE DURING THE ASSEMBLY  
PROCESS!

MEASURE BOLT DIAMETER BY PLACING INSIDE CIRCLE

- #10
- 1/4"
- 5/16"
- 3/8"
- 7/16"
- 1/2"

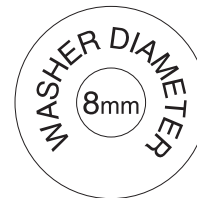
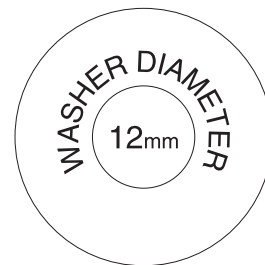
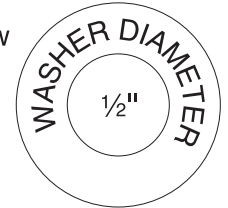
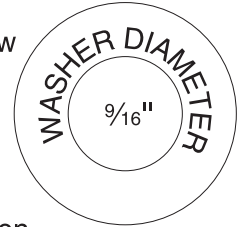
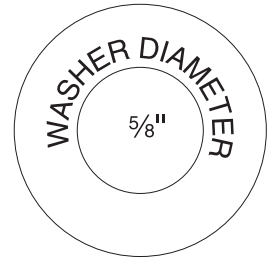
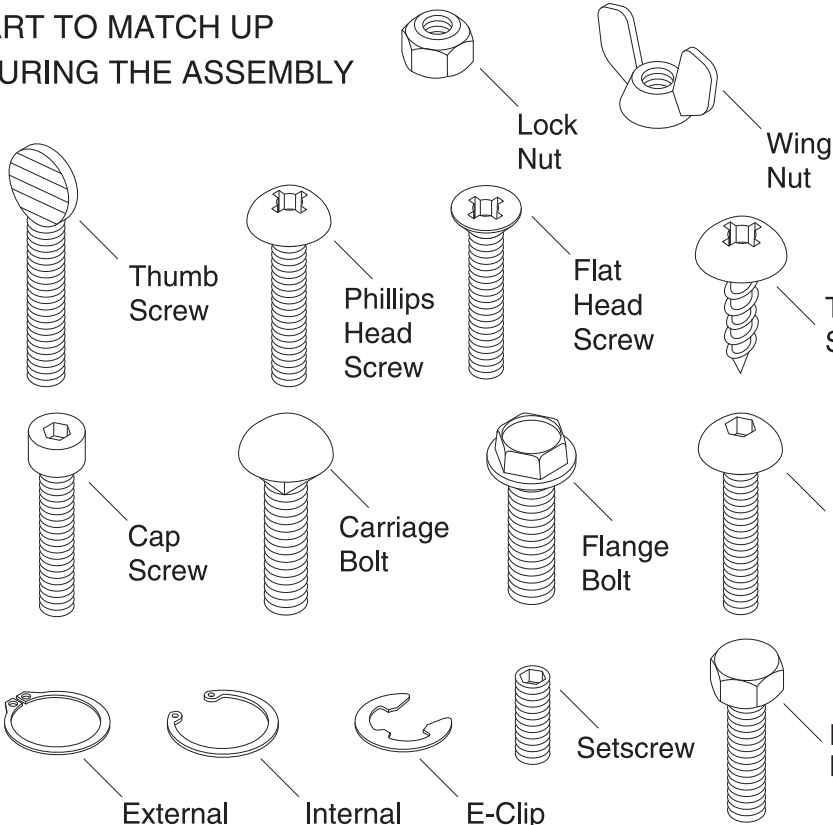

#10

LINES ARE 1MM APART

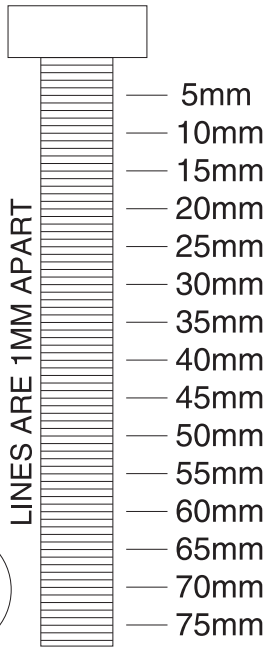

LINES ARE 1/16" INCH APART

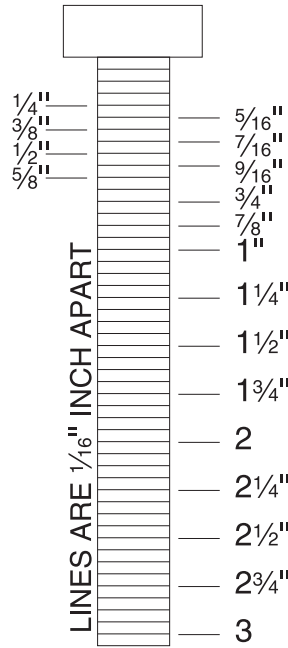

WASHERS ARE MEASURED BY THE INSIDE DIAMETER

- 4mm
- 6mm
- 8mm
- 10mm
- 12mm
- 16mm



# Machine Inventory

The following components are included with each G1023SL Series model. After all the parts have been removed from their packaging, you should have:

Box Contents (Figures 5 & 6)	Qty
A. Table Saw Unit.....	1
B. Splitter/Guard Assembly.....	1
C. Cabinet Cover .....	1
D. Extension Wing .....	1*
E. Miter Gauge.....	1
F. Arbor Wrench .....	1
G. Switch Brace .....	1
H. Dust Port .....	1
I. Support Shaft .....	1
J. Support Shaft Bracket (2 pc).....	1
K. Standard Table Insert.....	1
L. Dado Table Insert.....	1
M. Handwheel Lock Knob .....	1
N. Handwheel Handle .....	1

\* The Model G1023SL comes with two extension wings.



Figure 5. G1023SL basic table saw unit.

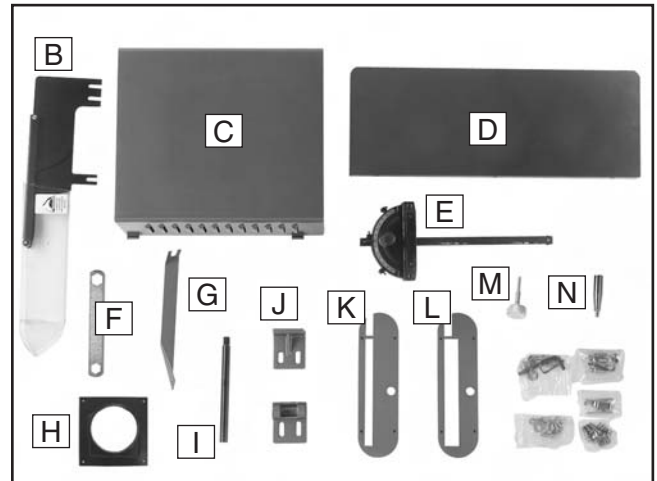

Figure 6. G1023SL component inventory.

Hardware Bags:	Qty
• Flat Head Screw 5/16"-18 x 1" (Switch).....	1
• Flat Washer 5/16" (Switch) .....	1
• Hex Nut 5/16"-18 (Switch).....	1
• Tap Screws #10 x 3/8" (Dust Port) .....	4
• Latch (Motor Cover) .....	1
• Phillips Head Screw #8-32 x 3/8" (Latch) ....	2
• Hex Nut #8-32 (Latch).....	2
• Hinge Pins (Motor Cover).....	2
• Set Screw 5/16"-18 x 3/8" (Bracket/Shaft) .....	2
• Hex Bolt 5/16"-18 x 1 1/2" (Shaft Brackets) .....	2
• Flat Washers 5/16" (Shaft Brackets).....	4
• Lock Washers 5/16" (Shaft Brackets) .....	2
• Hex Nuts 5/16"-18 (Shaft Brackets) .....	2
• Hex Bolt 5/16"-18 x 1" (Bracket/Splitter) .....	2
• Flat Washers 5/16" (Bracket/Splitter).....	2
• Hex Wrenches 3, 4, 8mm .....	1 Each
• Wrench 9/16".....	1
• Open-End Wrench 22mm .....	1

In the event that any nonproprietary parts are missing (e.g. a nut or a washer), we would be glad to replace them; or for the sake of expediency, replacements can be obtained at your local hardware store.

## NOTICE

Some hardware/fasteners on the inventory list may arrive pre-installed on the machine or related components. Check these locations before assuming that any items from the inventory list are missing.



# Fence Inventory G1023SL, W, WX, WX3

The Shop Fox Classic fence includes extra hardware for mounting it to other brands of table saws. Only the hardware needed to mount the fence to your Grizzly saw is listed in this inventory and shown in **Figure 7**. To avoid confusion, we suggest removing any items not listed here from your immediate work area.

Inventory Needed for Your Saw:	Qty
A. Fence Assembly.....	1
B. Front Rail 46½".....	1
C. Back Rail 46½".....	1
D. Front Rail Rectangular Tube 54".....	1
E. Scale.....	1

### Rail Mounting Hardware:

- Hex Bolt ¼-20 x ¾" (Rail/Tube) ..... 4
- Flat Washer ¼" (Rail/Tube)..... 4
- Hex Bolt ¾-16 x 1" (Rail/Table)..... 4
- Flat Washer ¾" (Rail/Table)..... 4

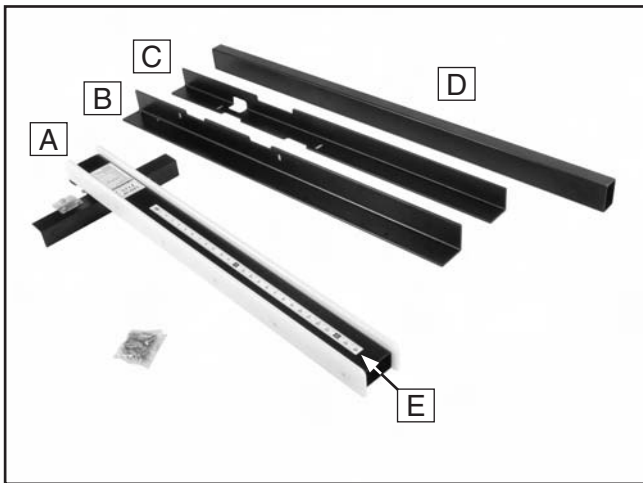

**Figure 7.** Inventory needed to install the fence on the Model G1023SL/W/WX/WX3.

# Fence Inventory G1023SLX

The Shop Fox Classic fence with 7' long rails includes extra hardware and two extra legs. Only the hardware needed to mount the fence to your Grizzly saw is listed in this inventory and shown in **Figure 8**. To avoid confusion, we suggest removing any items not listed here from your immediate work area.

Inventory Needed for Your Saw:	Qty
A. Front Rail Rectangular Tube 84".....	1
B. Extension Table.....	1
C. Legs.....	2
D. Feet.....	2
E. Front Rail 72".....	1
F. Back Rail 72".....	1
G. Fence Assembly.....	1
H. Leg Braces.....	2
I. Scale.....	1

### Rail/Table Mounting Hardware:

- Hex Bolt ¾-16 x 1" (Rail/Main Table)..... 4
- Flat Washer ¾" (Rail/Main Table) ..... 4
- Hex Bolt ¾-16 x 1¾" (Rail/Ext Table) ..... 8
- Flat Washer ¾" (Rail/Ext Table)..... 16
- Hex Nut ¾-16 (Rail/Ext Table)..... 8
- Wood Screw #8 x ⅝" (Leg/Ext Table)..... 12
- Hex Bolt ¾-16 x ¾" (Brace/Leg) ..... 2
- Flat Washer ¾" (Brace/Leg)..... 2
- Wood Screw ¼" x ¾" (Brace/Ext Table) .... 2
- Flat Washer ¼" (Brace/Ext Table) ..... 2

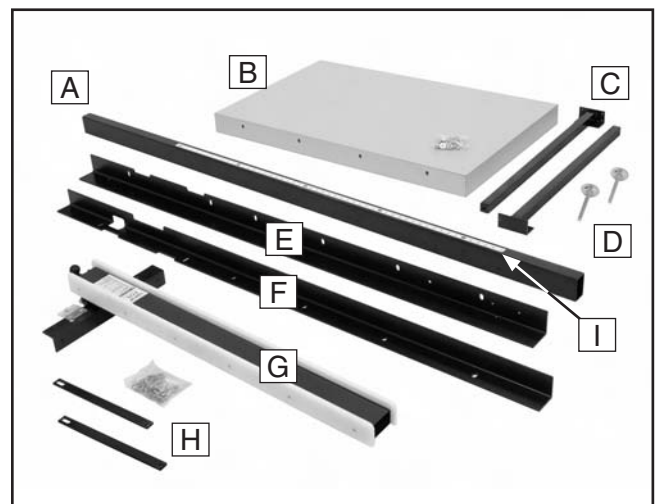

**Figure 8.** Inventory needed to install the fence on the Model G1023SLX.



# Router Table Inventory

Components:	Qty
A. Table .....	1
B. Clamp Assemblies.....	4
C. Table Insert 29mm .....	1
D. Table Insert 60mm .....	1
E. Legs.....	2
F. Feet .....	2

### Hardware:

- Hex Bolts  $\frac{3}{8}$ "-16 x  $1\frac{1}{4}$ " (Rtr/Main Table) .... 3
- Lock Washers  $\frac{3}{8}$ " (Rtr/Main Table) ..... 3
- Flat Washers  $\frac{3}{8}$ " (Rtr/Main Table)..... 3
- Hex Bolts  $\frac{3}{8}$ "-16 x  $1\frac{1}{4}$ " (Rtr Table/Rail)..... 2
- Lock Washers  $\frac{3}{8}$ " (Rtr Table/Rail)..... 2
- Flat Washers  $\frac{3}{8}$ " (Rtr Table/Rail) ..... 2
- Hex Nuts  $\frac{3}{8}$ "-16 (Rtr Table/Rail) ..... 2
- Flat Head Screws  $\frac{1}{4}$ "-20 x  $\frac{3}{4}$ " (Rail/Leg) ... 4
- Flat Washers  $\frac{1}{4}$ " (Rail/Leg) ..... 2
- Hex Nuts  $\frac{1}{4}$ "-20 (Rail/Leg) ..... 2

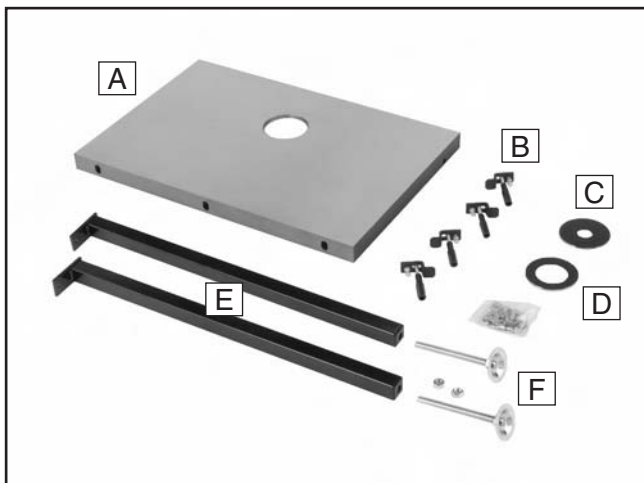



Figure 9. Router table extension wing inventory.

# Clean Up

The unpainted surfaces are coated with a waxy oil to protect them from corrosion during shipment. Remove this protective coating with a solvent cleaner or citrus-based degreaser such as Grizzly's G7895 Degreaser. To clean thoroughly, some parts may need to be removed. **For optimum performance from your machine, make sure you clean all moving parts or mating surfaces that are coated.** Avoid chlorine-based solvents, such as acetone or brake parts cleaner, as they may damage painted surfaces should they come in contact. Always follow the manufacturer's instructions when using any type of cleaning product.



**! WARNING**  
Gasoline and petroleum products have low flash points and could cause an explosion or fire if used to clean machinery. **DO NOT** use gasoline or petroleum products to clean the machinery.

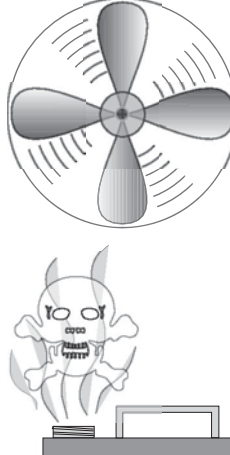

**! CAUTION**  
Many of the solvents commonly used to clean machinery can be toxic when inhaled or ingested. Lack of ventilation while using these solvents could cause serious personal health risks or fire. Take precautions from this hazard by only using cleaning solvents in a well ventilated area.



# Site Considerations

Consider existing and anticipated needs, size of material to be processed through each machine, and space for auxiliary stands, work tables or other machinery when establishing a location for your new machine.

See **Figures 10–12** for the overall size of each machine.

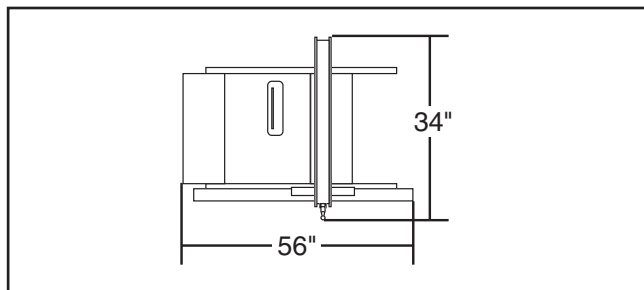

**Figure 10.** G1023SL overall size.

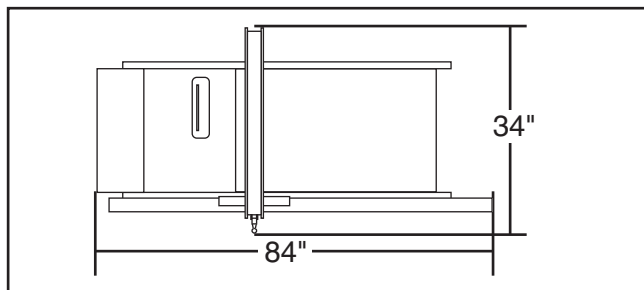

**Figure 11.** G1023SLX overall size.

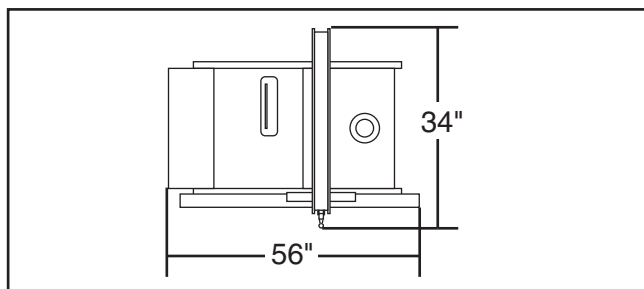

**Figure 12.** G1023SLW/WX/WX3 overall size.

# Motor Brace

The motor brace shown in **Figure 13** has been installed for shipping purposes. Please remove this brace before starting the assembly. The bolts that secure the brace should be threaded back into the locations from which they came.



**Figure 13.** Motor Brace.



# Tables

Inspect the extension wings for burrs or foreign material that may inhibit assembly. The mating edges of the wings and the table must be clean, smooth, and flat. Use a wire brush or file if necessary to clean up the edges.

**For all G1023SL Series models:** Mount a standard extension wing to the left-hand side of the table.

**For Model G1023SL:** Mount the other extension wing on the right-hand side of the table.

**For Model G1023SLW, G1023SLWX, and G1023SLWX3:** Wait until after the fence rails are installed to mount the router table extension wing to the right-hand side of the table.

**For Model G1023SLX:** Wait until after the fence rails are installed to mount the extension table on the right-hand side of the saw.



## To install an extension wing:

1. Remove the three bolts and washers from the end of the table.
2. Have another person hold the extension wing in place and mount it to the main table with the three bolts and washers you removed in **Step 1**.
3. Use a straightedge as a gauge and adjust the extension wing up/down until it is flush with the main table above each bolt, then completely tighten the bolts.

4. Place the straightedge across the extension wing and main table to make sure that the combined table surface is flat.

— If the outside end of the extension wing tilts down, use a strip of masking tape along the bottom edge of the main table to shim the extension wing up (**Figure 14**).

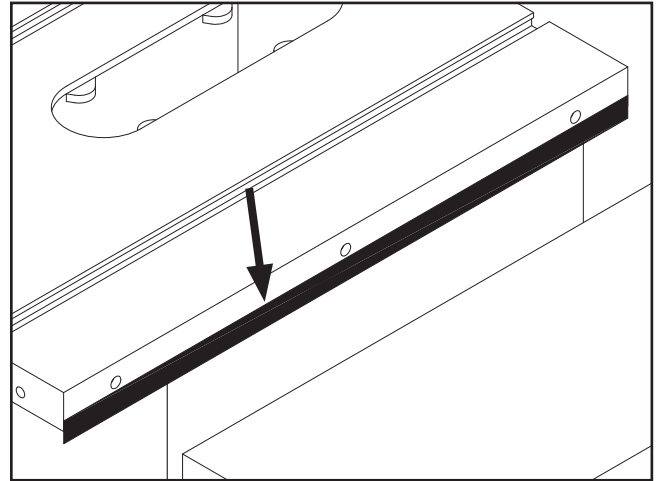

**Figure 14.** Masking tape location for tilting the extension table up.

— If the outside end of the extension wing tilts up, use a strip of masking tape along the top edge of the main table to shim the extension wing down (**Figure 15**).

**Note:** After reinstalling wings, remove all excess masking tape with a razor blade.

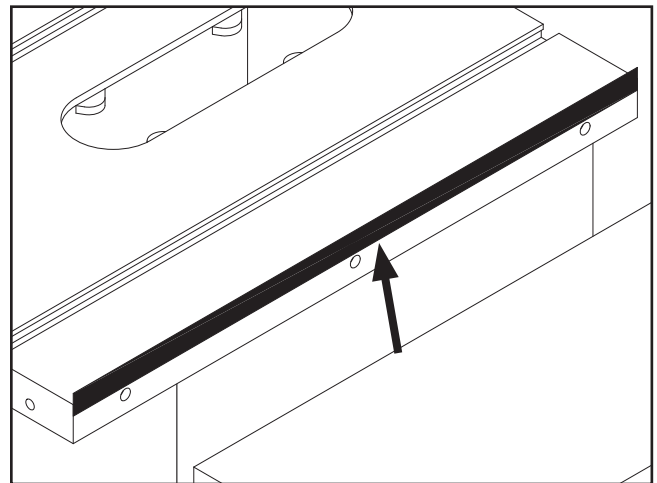

**Figure 15.** Masking tape location for adjusting the extension wing down.



# Switch

## To mount the switch:

1. Attach the switch to the extension wing with a  $\frac{5}{16}$ "-18 x 1 flat head screw in front, as shown in **Figure 16**, and a  $\frac{5}{16}$ " flat washer and  $\frac{5}{16}$ " hex nut in back.



**Figure 16.** Installing switch.

2. Mount the switch brace, as shown in **Figure 17**, using the table mounting fasteners on the top end and the switch mounting fasteners on the bottom end.

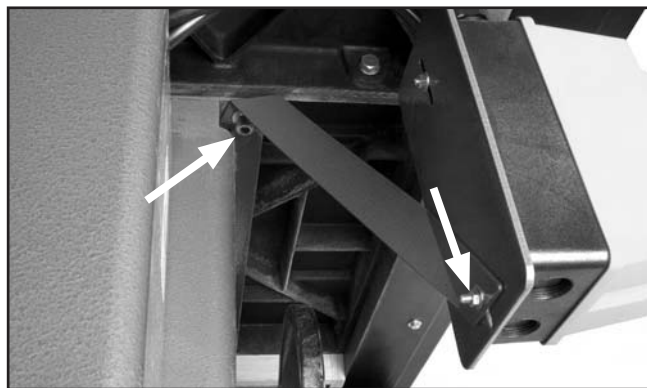

**Figure 17.** Installing switch bracket.

# Fence

Install your fence now, using the instructions provided with the fence.

# Router Table & Legs G1023SLW, WX, WX3

## To install the router table and extension legs:

1. Use (3)  $\frac{3}{8}$ "-16 x  $1\frac{1}{4}$ " hex bolts, (3)  $\frac{3}{8}$ " lock washers, and (3)  $\frac{3}{8}$ " flat washers to secure the router table to the main table, making sure the tables are flush.
2. Place a straightedge across the router table and the main table to make sure that the combined table surface is flat.  
  
—If the router table tilts up/down, shim it in the same manner as described in the **Tables** setup instructions.
3. Use (2)  $\frac{3}{8}$ "-16 x  $1\frac{1}{4}$ " hex bolts, (2)  $\frac{3}{8}$ " lock washers, (2)  $\frac{3}{8}$ "- $\frac{3}{8}$ " flat washers, and  $\frac{3}{8}$ " hex nuts to secure the router table to the front/back fence rails.
4. Thread the feet into the legs so the leg/foot assembly is shorter than the rail height.
5. Use (4)  $\frac{1}{4}$ "-20 x  $\frac{3}{4}$ " flat head screws, (4)  $\frac{1}{4}$ " flat washers, and (4)  $\frac{1}{4}$ " hex nuts to secure the legs to the fence rails.
6. Adjust the feet to the ground, then tighten the hex nut on the foot against the leg to lock the foot height in place. **Figure 18** shows the router table extension wing installed on the saw.



**Figure 18.** Router table and legs installed.



# Extension Table & Legs G1023SLX

## To install the extension table:

1. Use the (8)  $\frac{3}{8}$ "-16 x  $1\frac{3}{4}$ " hex bolts, (16)  $\frac{3}{8}$ " flat washers, and (8)  $\frac{3}{8}$ " hex nuts to secure the extension table to the rails, as shown in **Figure 19**.

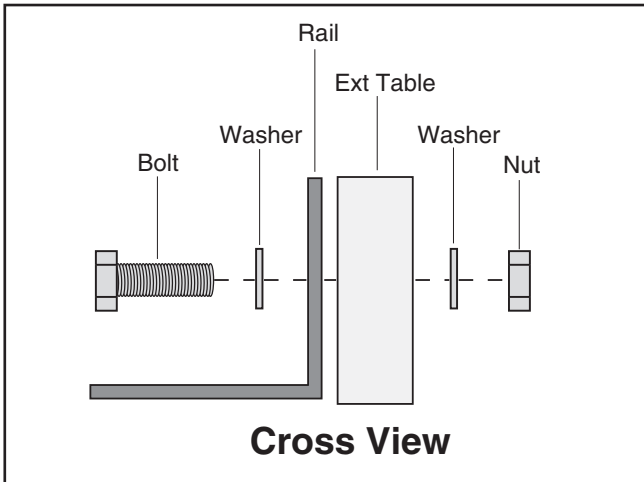

**Figure 19.** Attaching extension table to the rails.

2. Thread the feet into the legs, place the legs under the table, and thread the feet out until the top of the leg is against the underside corner of the table.
3. Use the (12) #8 x  $\frac{5}{8}$ " wood screws to fasten the legs to the underside corners of the extension table.
4. Use the (2)  $\frac{3}{8}$ "-16 x  $\frac{3}{4}$ " hex bolts and (2)  $\frac{3}{8}$ " flat washers to loosely attach the brace to the legs.

5. Use the (2)  $\frac{1}{4}$ " x  $\frac{3}{4}$ " wood screws and (2)  $\frac{1}{4}$ " flat washers to attach the brace to the extension table, as shown in **Figure 20**.



**Figure 20.** Legs and leg braces mounted to the underside of the extension table.

6. Tighten the bolts that hold the brace to the leg.
7. Adjust the extension table so it is flat (both flush and parallel) with the main table. This can be done by loosening the mounting bolts and adjusting the feet up/down as needed. **Figure 21** shows the extension table installed on the saw.
8. Tighten the extension table mounting bolts and tighten the hex nuts on the feet up against the legs so they will not move.



**Figure 21.** Extension table installed.



# Motor Cover

To install the motor cover:

1. Attach the latch to the motor cover with the (2) #8-32 x  $\frac{3}{8}$ " Phillips head screws and (2) #8-32 hex nuts.
2. Place the motor cover on the stand, line up the hinges, and tap the hinge pins into the hinges with a hammer.



Figure 22. Motor cover installed on stand.

# Dust Port

Mount the dust port onto the stand with the (4) #10 x  $\frac{3}{8}$ " tap screws, as shown in **Figure 23**.



Figure 23. Dust port installed on cabinet.

# Handwheel Lock Knob & Handle

To install, place the handwheel over the threads and screw the lock knob into the center.

Next insert the handwheel handle into the handwheel and tighten it.



Figure 24. Handle and lock knob installed on handwheel.



# Table Insert

The table insert provides access to the blade and the arbor when removed, and it provides support for the materials being cut when installed.

## To install and adjust the table insert:

1. DISCONNECT POWER TO THE SAW!
2. Ensure that all four set screws are firmly in contact with the table casting.
3. Using a 3mm hex wrench, raise or lower each of the four set screws shown in **Figure 25** until the insert is flush with the table top. Use a straightedge to make sure the table insert is flush with the top of the table.

## NOTICE

The table insert must be flush with the table top or the workpiece will hit the edge of the table insert at the beginning of the cut.

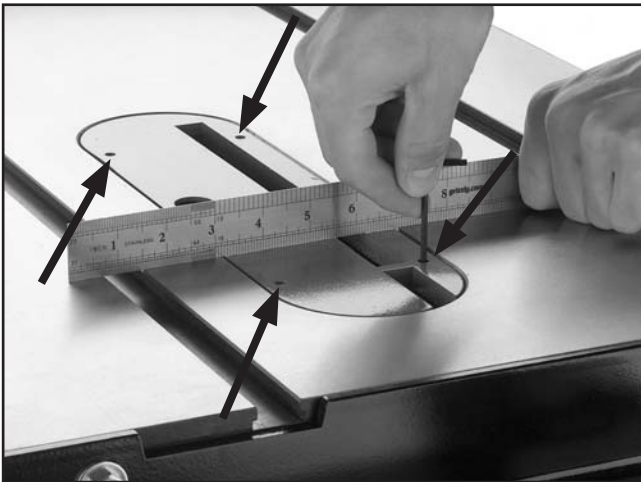
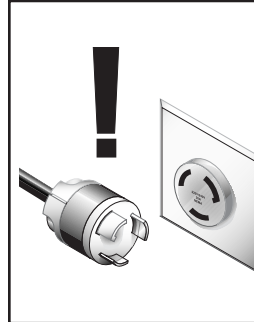

**Figure 25.** Adjusting set screws on each corner of insert.

# Saw Blade

## ! WARNING

The saw blade is extremely sharp. Use extra care when handling the blade or working near it. Serious injury is possible.



## ! WARNING

Disconnect power to the machine when performing any maintenance, assembly or adjustments. Failure to do this may result in serious personal injury.

Review this section even if your saw blade came pre-installed.

## To install the blade:

1. Remove the table insert to gain access to the arbor.
2. Remove the nut and the outer arbor flange from the arbor.
3. Place the blade on the arbor, making sure that it seats firmly against the inner arbor flange. Ensure that the top blade teeth are facing the front of the saw.
4. Replace the outer arbor flange and thread the arbor nut onto the arbor.
5. Hand tighten the nut and snug with the wrench included with the saw. DO NOT overtighten.

**IMPORTANT:** Make sure the blade is installed with the teeth facing the front of the saw.

6. Make sure the blade will not contact the table insert when raised to the maximum height and rotated by hand at 90° and 45° angles. Wear leather gloves while rotating the blade to prevent being cut.



# Guard Bracket

## To install the guard support shaft:

1. Thread the shaft into the tilt assembly through the hole in the back of the saw, and tighten it with a screwdriver shaft, as shown in **Figure 26**.



**Figure 26.** Attaching guard support shaft.

2. Slide the lower half of the bracket onto the splitter shaft and temporarily secure it with the (2)  $\frac{5}{16}$ "-18 x  $\frac{3}{8}$ " set screws.
3. Place the upper bracket half on the lower half and secure both halves with the (2)  $\frac{5}{16}$ "-18 x  $1\frac{1}{2}$ " hex bolts, (4)  $\frac{5}{16}$ " flat washers, (2)  $\frac{5}{16}$ " lock washers and (2)  $\frac{5}{16}$ " hex nuts as shown in **Figure 27**. Do not fully tighten the nuts at this moment.

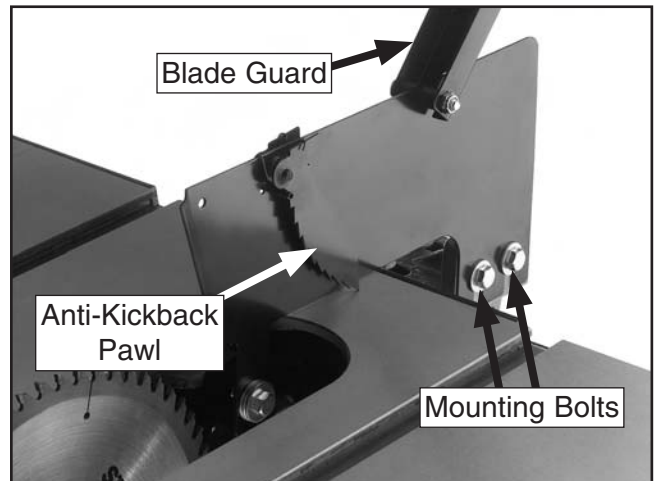

**Figure 27.** Splitter bracket installed.

# Blade Guard/Splitter

## To install the blade guard/splitter:

1. Use the (2)  $\frac{5}{16}$ "-18 x 1" hex bolts and (2)  $\frac{5}{16}$ " flat washers to secure the splitter to the mounting bracket assembly, as shown in **Figure 28**.



**Figure 28.** Blade guard and splitter in place.

2. Set a machinist's square against the face of the blade splitter. Slightly rotate the rear bracket to adjust the face of the blade splitter perpendicular to the table top, as shown in **Figure 29**.

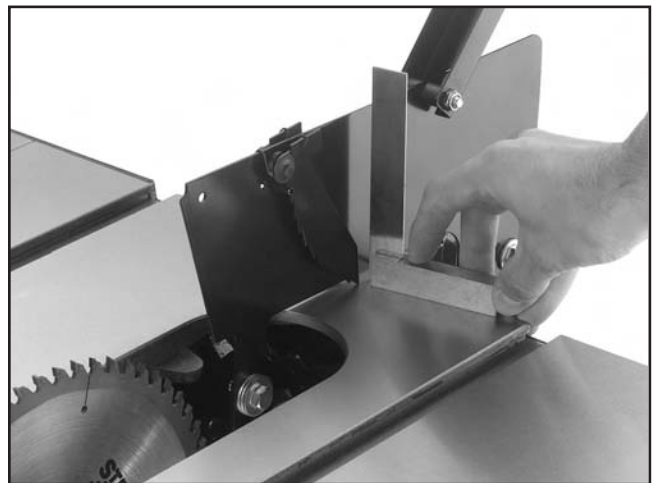

**Figure 29.** Blade splitter square to table.



# ⚠️ WARNING

The saw blade is extremely sharp. Use extra care when handling the blade or working near it. Serious injury is possible.

3. Next, set a straightedge against the face of the saw blade and the blade splitter as shown in **Figure 30**.

—If the blade splitter is properly aligned, then no further adjustments are necessary; otherwise, continue with the next step.

—If the blade splitter is to the right of the blade as shown in **Figure 31**, add washers between the splitter and the front mounting bracket, and adjust the rear splitter support as shown in **Figure 32**.

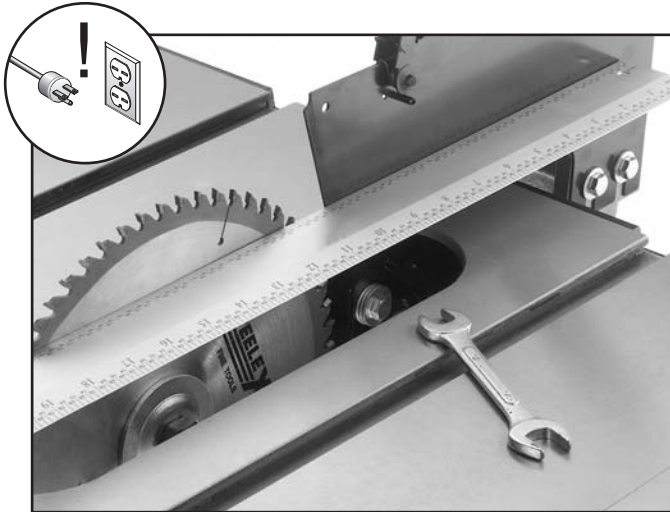

**Figure 30.** Guard in line with blade.

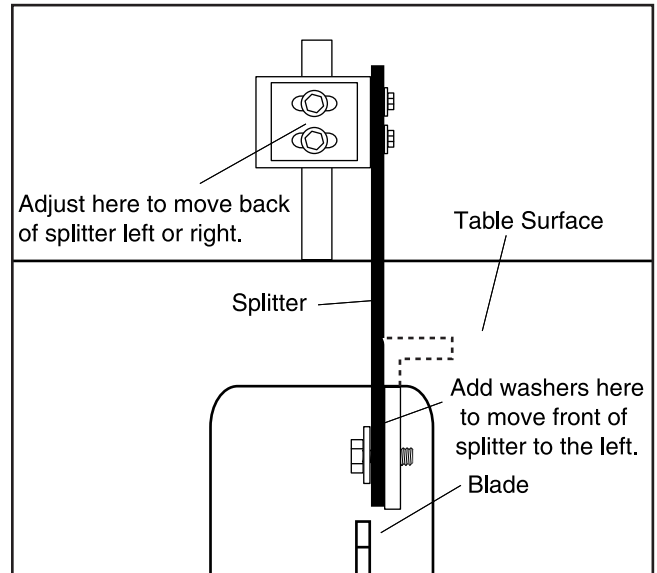

**Figure 31.** Improper splitter/blade alignment.

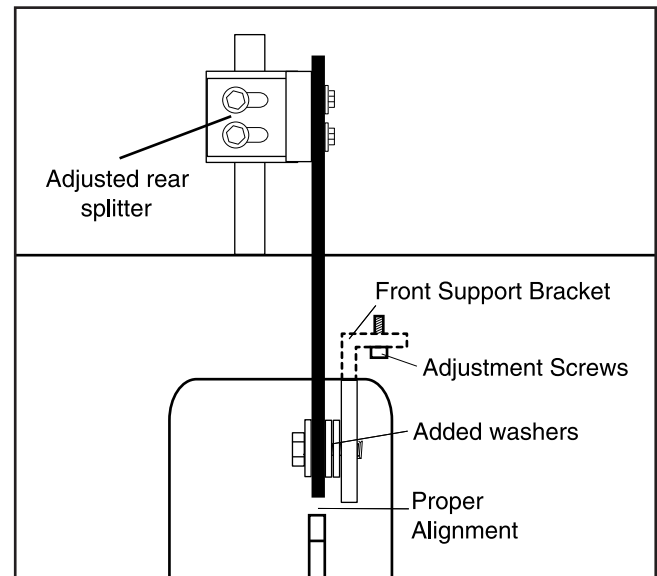

**Figure 32.** Proper splitter/blade alignment.



5. Recheck the splitter alignment to the blade and to the table top. Adjust as necessary and tighten all the bolts before use.

—If the blade guard is properly aligned, skip ahead to **Step 10**; otherwise, continue with the next step.

—If the splitter is positioned to the left of the blade, alignment cannot be achieved by washer placement. Adjustment of the front support bracket is required. See **Figure 32** for adjustment details. Loosen the (2) adjustment screws and move left or right.

—If this adjustment does not allow enough movement of the splitter, remove the table and wings, and set them to one side.



6. The arbor bracket and motor pulley needs adjusting. Loosen the adjustment bolt shown in **Figure 33**, and slowly slide the arbor bracket towards the end of the shaft.

**Note:** Only move the arbor bracket a distance equal to the amount of misalignment between the blade and the splitter, or a little more. You can always adjust the splitter back to the left with washers. Tighten the adjustment bolt securely.

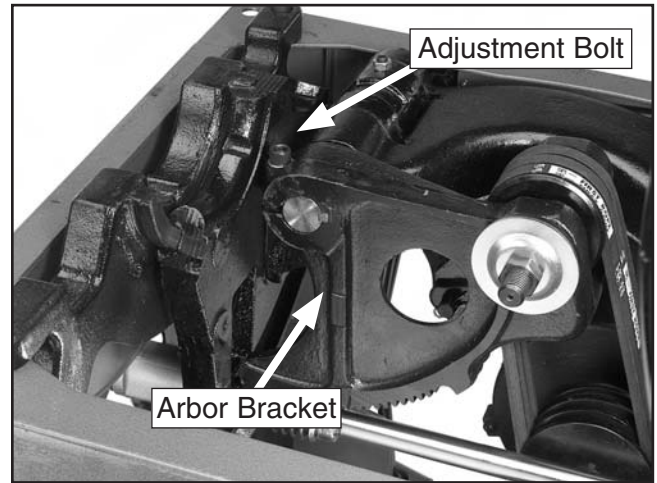

**Figure 33.** Arbor bracket adjustment locations.

7. Moving the arbor bracket moves the V-belts and pulleys out of alignment, so adjustment of the motor pulley is required. Simply loosen the set screw in the middle groove of the pulley, and slowly slide the pulley toward the end of the motor shaft. Once the V-belts are back in alignment, tighten the set screw securely.
8. Recheck the guard alignment to the blade and to the table top. Adjust as necessary and tighten down all the bolts before use. If the blade guard is properly aligned, re-attach the table, making sure there is adequate blade clearance through all blade adjustments.
9. Adjust the blade to 45°. Raise and lower it through the full range. Re-adjust the blade to 90°, then raise and lower it through the full range. There should be no contact between the blade, the base, the table insert, or any other part of the saw. If there is contact, repeat **Steps 7-9**.



# Pre-Run Check

---

---

Before you do the Test Run, review the following questions to reduce your risk of an injury or accident:

1. Have you read all the warnings and directions regarding the operation of this machine?
2. Are all the fasteners tight?
3. Is the blade mounted correctly?
4. Is the cabinet stable?
5. Is the fence parallel with the blade?
6. Is your electrical system properly configured and wired correctly?
7. Are the V-belts properly tensioned and the pulleys properly aligned?
8. Is the guard assembly installed, aligned with the blade, and functional?
9. Have you checked the saw blade clearance when it is adjusted to varying angles and depths?
10. Have you checked your workpiece for obvious defects?

# Test Run

---

---

1. Connect the table saw to the power source.
2. Face the table saw and stand to the left of the blade path.
3. With one finger on the START button and one finger on the STOP button, turn the saw on. Be ready to turn the saw off in case of a mishap.
4. Watch and listen to the saw. Note whether there are any unusual sounds or excessive vibrations.
5. If anything appears abnormal, immediately turn off the saw, unplug it, and fix the problem. If a problem exists that is beyond the scope of this manual, call our service department.
6. If the saw is behaving normally, turn it off and prepare to make a cut according to the instructions outlined in **SECTION 4: OPERATIONS**.



# SECTION 4: OPERATIONS

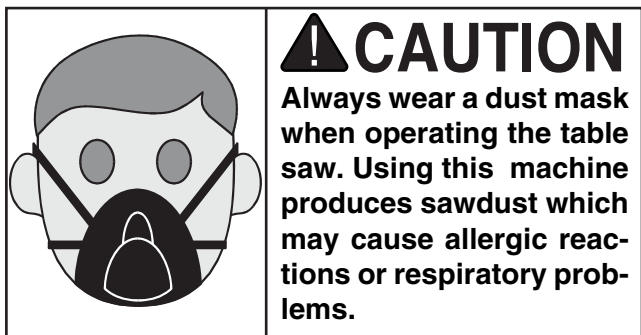
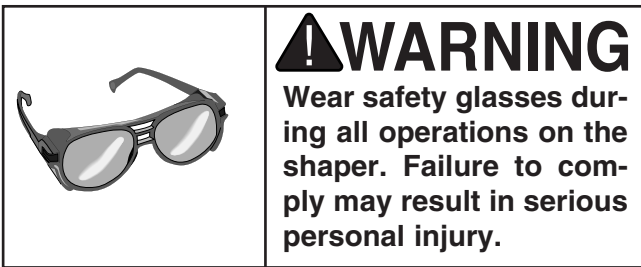

## NOTICE

The following section was designed to give instructions on the basic operations of this table saw. However, it is in no way comprehensive of every table saw application. There are many different jigs that can be built to increase safety, accuracy, and types of cuts. **WE STRONGLY RECOMMEND** that you read books, trade magazines, or get formal training, especially if using the router table extension wing!

## Basic Controls

The basic controls for the table saw are shown in **Figure 34**. Setting up for a typical operation consists of the following three steps:

1. Make sure the blade tilt is correct. If it needs to be adjusted, use the blade tilt handwheel and always tighten the blade tilt lock after adjustments have been made.
2. Set the blade height approximately  $\frac{1}{4}$ " higher than the workpiece thickness by turning the blade height handwheel, then lock the blade height in place by tightening the blade height lock.
3. Adjust the fence to the desired width of cut, then lock it in place by firmly pushing the fence lock down until it stops.

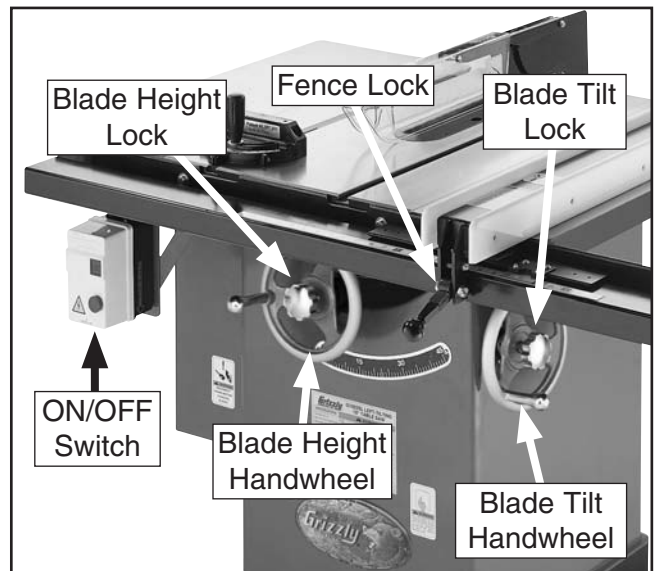

**Figure 34.** Basic table saw controls.



# Mounting Router G1023SLW, WX, WX3

## To mount a router to the router table:

1. Slide the router clamps into the T-slots on the underside of the table (**Figure 35**).

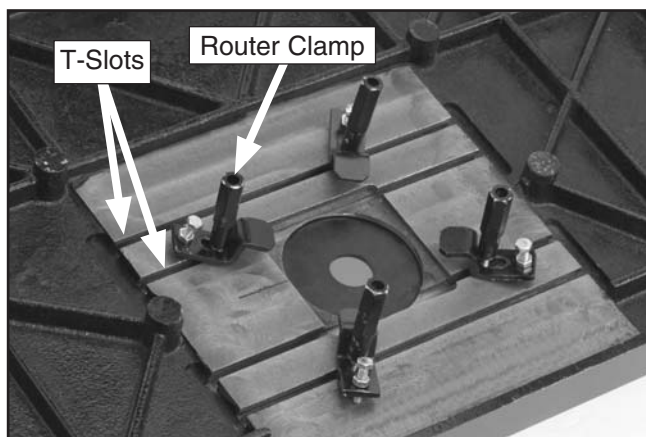

**Figure 35.** Installing the router clamps

2. Loosen the router clamps, and install the router so the base presses flat against the underside of the table (**Figure 36**).

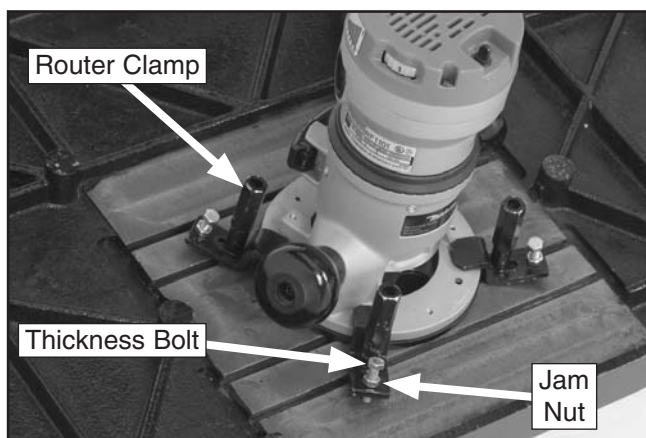

**Figure 36.** Router mounted under wing.

3. Adjust the thickness bolts and the jam nuts on each of the router clamps to pinch the router base against the table. (The thickness bolt should press against the bottom of the table—not inside the T-slot.)
4. Tighten the router clamps to secure the router base into position.
5. Set the table insert into the table recess.



# Blade Selection

## Ripping blade features:

- Best for cutting with the grain of the workpiece.
- 20-40 teeth.
- Flat-top ground tooth profile.
- Large gullets for large chip removal.

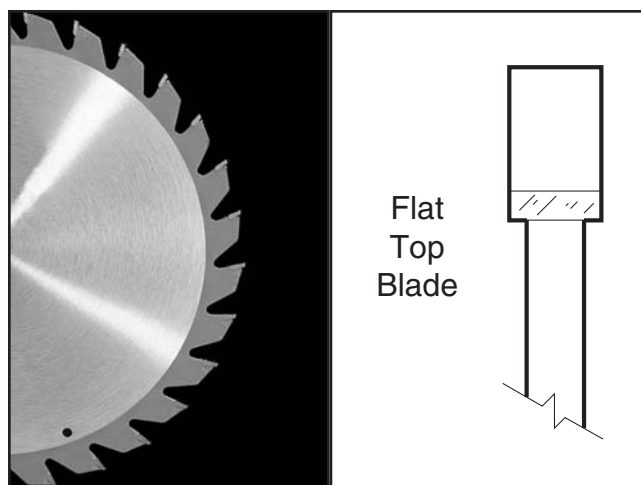

**Figure 37.** Ripping blade.

## Crosscut blade features:

- Best for cutting across the grain of the workpiece.
- 60-80 teeth.
- Alternate top bevel tooth profile.
- Small hook angle and a shallow gullet.

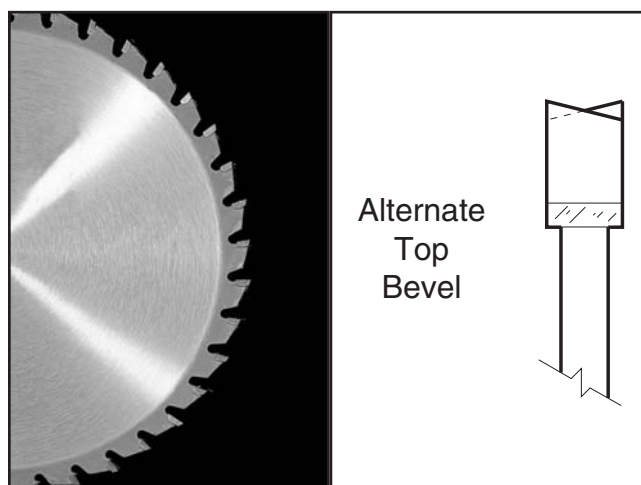

**Figure 38.** Crosscutting blade.

### Combination blade features:

- Adequate for cutting both with and across the grain.
- 40-50 teeth.
- Alternate top bevel and flat, or alternate top bevel and raker tooth profile.
- Teeth are arranged in groups of five.
- Gullets are small and shallow within the groups of five teeth, similar to a cross-cut blade; then large and deep between each group of five, like a ripping blade.

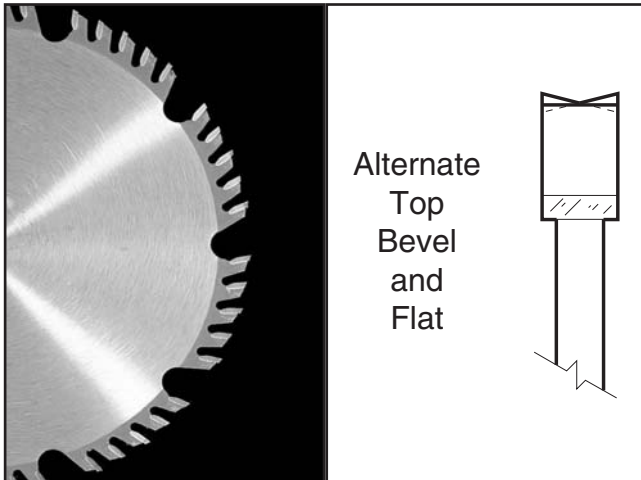

Figure 39. Combination blade.

### Laminate blade features:

- Best for cutting plywood or veneer.
- 40-80 teeth.
- Triple chip tooth profile.
- Very shallow gullet.

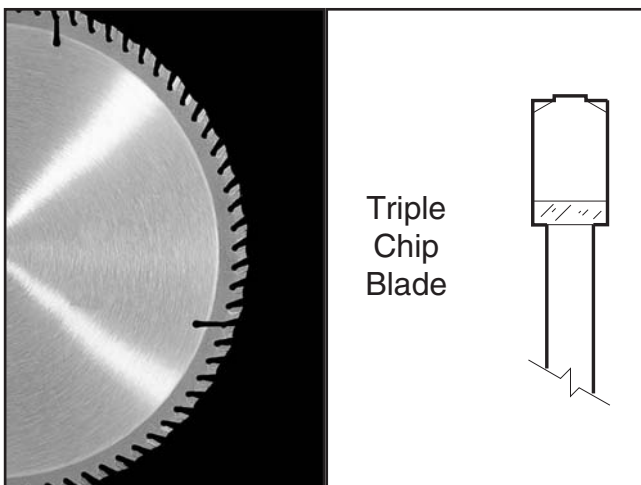

Figure 40. Laminate blade.

### Dado Blades:

There are two types of dado blades: stacked and wobble.

- **Stacked Dado Blade:** These dedicated dado cutting blade sets consist of up to 8 individual blades. Multiple cutters are "stacked" between two outside blades. The width of the dado is determined by the combination of cutters that are "stacked" together. The dado is cut in a single pass leaving a smooth and square channel in the face of the workpiece. Stacked dado blades are the most expensive option, but are worth considering if your projects require a lot of visible dado cuts. A stacked dado blade is shown in **Figure 41**.

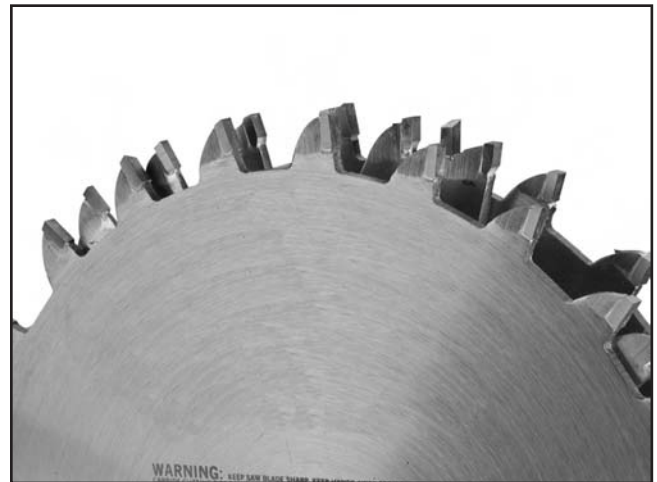

Figure 41. Stacked dado blade.

- **Wobble Dado Blade:** Also a dedicated dado blade, a wobble blade usually consists of a single blade that is tilted on the arbor shaft while it is spinning. The channel is cut in the face of the workpiece as the blade passes through its pre-adjusted width of travel. Wobble blades are an inexpensive option when visibly pleasing channels are not a concern.

**Note:** This section on blade selection is by no means comprehensive. Always follow the saw blade manufacturer's recommendations to ensure safe and efficient operation of your table saw.



# Non-Through and Through Cuts

---

## Non-Through Cuts

A non-through cut is a sawing operation where the blade does not protrude above the top face of the wood stock. Non-through cuts require the removal of the blade guard and splitter. Dado cuts, rabbet cuts, and resawing are the only non-through cuts that can be performed with this table saw.

## Through Cuts

A through cut is a sawing operation in which the workpiece is completely sawn through. Ripping, crosscutting, miter cuts, and angled cuts are all through cutting operations.

Both through and non-through cuts have a risk of kickback. Kickback is an event in which the workpiece is propelled back towards the operator at a high rate of speed. Non-through cuts have a higher risk of injury from kickback because the splitter and blade guard must be removed. Always remember to re-install the blade guard and splitter after performing a non-through cut.

Read, understand, and follow the instructions and safety precautions for each type of cut to reduce the risk of injury.

**Safety precautions and instructions for each type of cut are located on the following pages:**

**Ripping: On this page.**

**Crosscutting: Page 32**

**Miter Cuts: Page 33**

**Blade Tilt/Bevel Cuts: Page 33**

**Dado Cutting: Page 34**

**Rabbet Cutting: Page 36**

**Resawing: Page 38**

# Ripping

---

Ripping means cutting with the grain of the workpiece. In other materials such as MDF or plywood, ripping simply means cutting lengthwise.

## WARNING

**Serious injury can be caused by kickback. Kickback is a high-speed expulsion of stock from the tablesaw toward an operator. The operator or bystanders may be struck by flying stock, or the operator's hands can be pulled into the blade during the kickback.**

### To make a rip cut:

1. Review **Preventing Kickback** on **Page 9** and take the necessary precautions to prevent kickback.
2. Joint one long edge of the workpiece on a jointer.
3. **DISCONNECT THE SAW FROM POWER!**
4. Set the fence to the desired width of cut on the scale.
5. Adjust the blade height so the highest saw tooth protrudes approximately  $\frac{1}{4}$ " above the workpiece.
6. Set up safety devices such as featherboards or other anti-kickback devices.
7. Rotate the blade to make sure it does not come into contact with any of the safety devices.

*Continued on next page* 



8. Plug the saw into the power source, turn it **ON**, and allow it to reach full speed.
9. The jointed edge of the workpiece must slide against the fence during the cutting operation.
10. Using a push stick, feed the workpiece through the saw blade, as shown in **Figure 42**, until the workpiece is completely past the saw blade.



**Figure 42.** Ripping operation.

## **!WARNING**

Turn **OFF** the saw and allow the blade to come to a complete stop before removing the cut-off piece. Failure to follow this warning could result in serious personal injury.

# Crosscutting

Crosscutting is cutting across the grain of the workpiece. In MDF or particleboard, crosscutting is cutting across the width of the workpiece.

### To make a crosscut using the miter gauge:

1. DISCONNECT THE SAW FROM POWER!
2. Remove the rip fence and position the miter gauge, adjusted to 90°, in a miter slot.
3. Adjust the blade height so the teeth protrude approximately 1/4" above the workpiece.
4. Slide the miter gauge near the blade and adjust the workpiece so the blade will cut on the waste side of the line.
5. Plug in the tablesaw, turn it **ON**, and allow it to reach full speed.
6. Hold the workpiece firmly against the face of the miter gauge and ease it into the blade as shown in **Figure 43**.

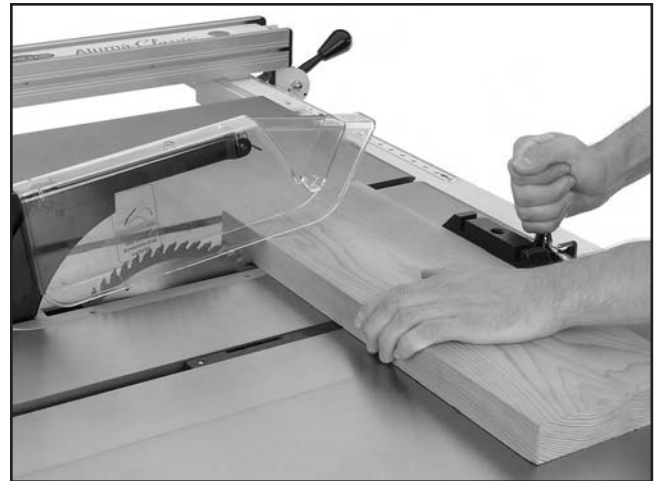

**Figure 43.** Crosscutting operation.

## **!WARNING**

Turn **OFF** the saw and allow the blade to come to a complete stop before removing the cut-off piece. Failure to follow this warning could result in serious personal injury



# Miter Cuts

A miter is an angled crosscut. Miters are usually cut in the same manner as crosscuts, using the miter gauge and a predetermined mark on the workpiece.

## To perform a miter cut:

1. DISCONNECT THE SAW FROM POWER!
2. Determine the angle of your cut. If the angle needs to be very precise, use a protractor to set the miter gauge to the blade.
3. Place the face of the miter gauge against the edge of the workpiece and place the bar across the face of the workpiece. Use the bar as a guide to mark your cut as shown in **Figure 44**.



**Figure 44.** Marking miter line.

4. Place the miter gauge back into the slot and hold the workpiece firm against the miter gauge body. Slide the miter gauge near the blade and adjust the workpiece so the blade will cut on the waste side of the line.
5. Proceed to make the cut in the same manner as described in the **Crosscutting** instructions.

# Blade Tilt/Bevel Cuts

When the positive stops are properly adjusted, the blade tilt handwheel allows the operator to tilt the blade to the left, anywhere between 0° and 45°. This is used most often when cutting bevels, compound miters or chamfers. **Figure 45** shows an example of the blade when tilted to 45°.



**Figure 45.** Blade tilted to 45° for bevel cutting on a typical table saw.



# Dado Cutting

Commonly used in furniture joinery, a dado is a straight channel cut in the face of the workpiece. Dadoes can be cut using either a dedicated dado blade or a standard saw blade.

The table saw motor is pushed to its limits when making a dado cut. If the motor starts to bog down, slow down your feed rate.

## **!WARNING**

Dado operations require proper procedures to avoid serious injury. Extra care must be taken to prevent kickback when using dado blades. Any movement of the workpiece away from the fence will cause kickback. Be certain that stock is flat and straight. Failure to follow these warnings could result in serious personal injury.

## **!WARNING**

DO NOT make a through-cut with a dado blade. Dado blades are not designed for through cuts. Failure to follow this warning could result in serious personal injury.

### To use a stacked or wobble dado blade:

1. DISCONNECT THE SAW FROM POWER!
2. Remove the table insert, the blade guard, and the saw blade.
3. Attach and adjust the dado blade system according to the dado blade manufacturer's instructions, then install the dado insert.

4. Raise the dado blade up to the desired depth of cut (depth of dado channel desired). When cutting deep dadoes, take more than one pass to reduce the risk of kickback.

## **!WARNING**

The danger of kickback increases relative to the depth and width of a cut. Reduce the risk of kickback by making multiple passes to achieve the desired depth of cut. Failure to follow these warnings could result in serious personal injury.

5. Adjust the distance between the fence and the inside edge of the blade as shown in **Figure 46** to dado the length of a workpiece.

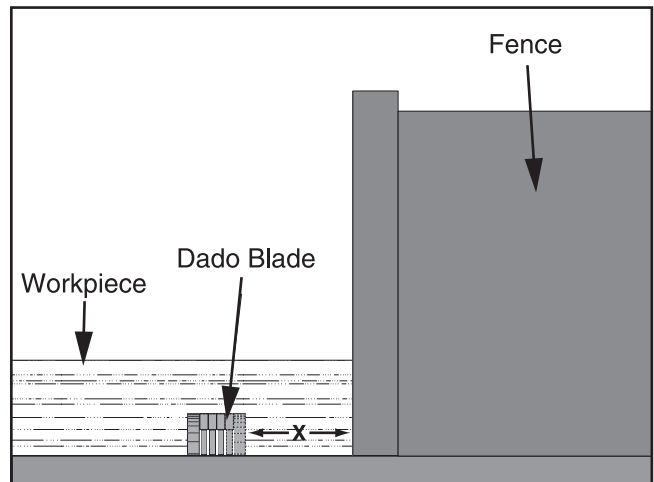

**Figure 46.** Stacked or wobble dado cut.

6. If dadoing across the workpiece, use the miter gauge and carefully line up the desired cut with the dado blade. DO NOT use the fence in combination with the miter gauge.
7. Reconnect the saw to the power source.



8. Turn the saw **ON** and keep one finger ready to push the STOP button. The blade should run smooth with no vibrations.
9. When the blade has reached full speed, perform a test cut with a scrap piece of wood.
10. If the cut is satisfactory, repeat the cut with the actual workpiece.

**To use a standard saw blade to cut dados:**

**Note:** Reduce motor overloading and blade wear by using a ripping blade. Ripping blades are designed to clear the sawdust quickly. See **Page 29** for more details.

1. DISCONNECT THE SAW FROM POWER!
2. Mark the width of the dado cut on the workpiece. Include marks on the edge of the workpiece so the cut path can be aligned when the workpiece is lying on the table.
3. Raise the blade up to the desired depth of cut (depth of dado channel desired). When cutting deep dados, take more than one pass to reduce the risk of kickback.

## **!WARNING**

The danger of kickback increases relative to the depth and width of a cut. Reduce the risk of kickback by making multiple passes to achieve the desired depth of cut. Failure to follow these warnings could result in serious personal injury.

4. If dadoing across the workpiece, use the miter gauge to support the workpiece, and align the blade to cut one of the dado sides. DO NOT use the fence in combination with the miter gauge.

5. If dadoing the length of a workpiece, align the blade to cut one of the dado sides as shown in **Figure 47**.

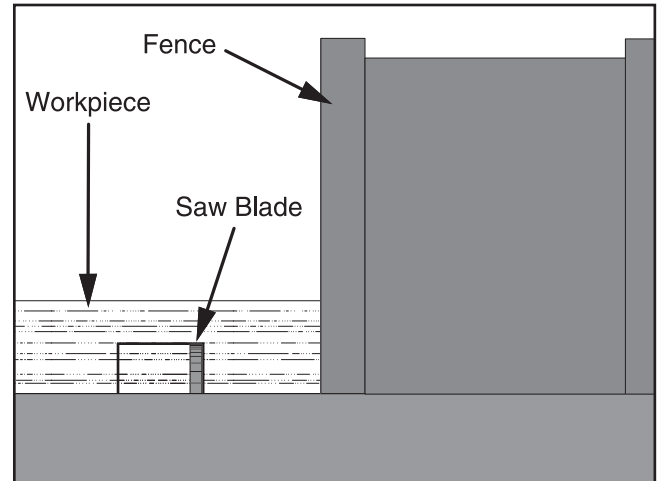

**Figure 47.** Single-blade dado first cut.

6. Reconnect the saw to the power source and turn the saw **ON**. Allow the blade to reach full speed.
7. Perform the cutting operation.
8. Re-adjust the fence so the blade is aligned with the other edge of the intended dado channel (**Figure 48**).

**Note:** Be sure to keep the cuts within your marks; otherwise, the dado will be too big.

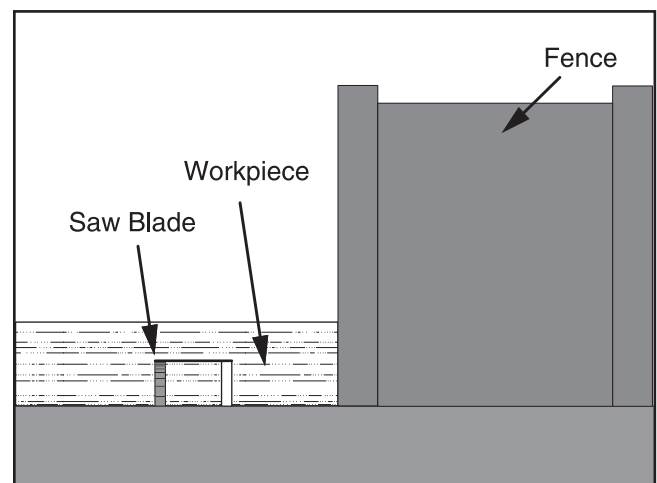

**Figure 48.** Single-blade dado second cut.

9. Continue making cuts toward the center of the dado until the dado is complete.



# Rabbet Cutting

## ⚠ CAUTION

You may experience kickback during this procedure. Stand to the side of the blade and wear safety glasses or a face shield to prevent injury when cutting rabbets.

Commonly used in furniture joinery, a rabbet is an L-shaped groove cut in the edge of the workpiece. Rabbets can be cut with either a dado blade or a standard saw blade.

### To attach a sacrificial fence:

Rabbet cutting on the edge of the workpiece requires a sacrificial fence attachment (**Figure 49**). Make the sacrificial fence the same length as the fence and  $\frac{3}{4}$ " thick. Attach it to the fence with screws or clamps, making sure they are all secure and tight. Raise the blade into the sacrificial fence to the height needed.

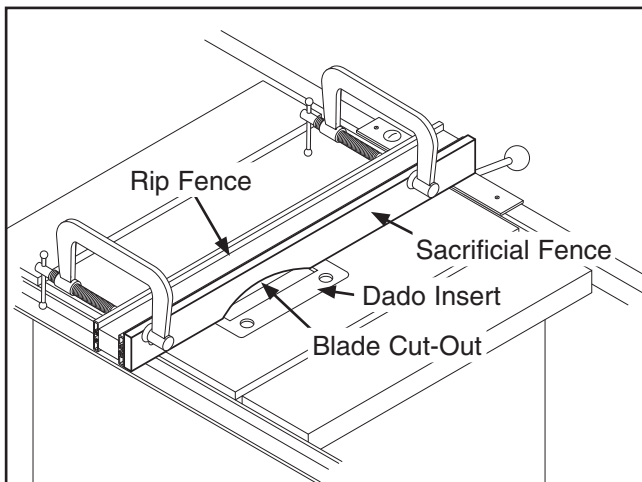

Figure 49. Sacrificial fence.

## ⚠ CAUTION

Always use push sticks, featherboards, push paddles and other safety accessories whenever possible to increase safety and control during operations which require that the blade guard and splitter must be removed from the saw. ALWAYS replace the blade guard after dadoing is complete.

### To cut rabbets with the dado blade:

1. DISCONNECT THE SAW FROM POWER!
2. Adjust the dado blade to the height needed for the rabbeting operation. When cutting deep rabbets, take more than one pass to reduce the risk of kickback.

## ⚠ WARNING

The danger of kickback increases relative to the depth and width of a cut. Reduce the risk of kickback by making multiple passes to achieve the desired depth of cut. Failure to follow these warnings could result in serious personal injury.

3. Adjust the fence and align the workpiece to perform the cutting operation as shown in **Figure 50**.

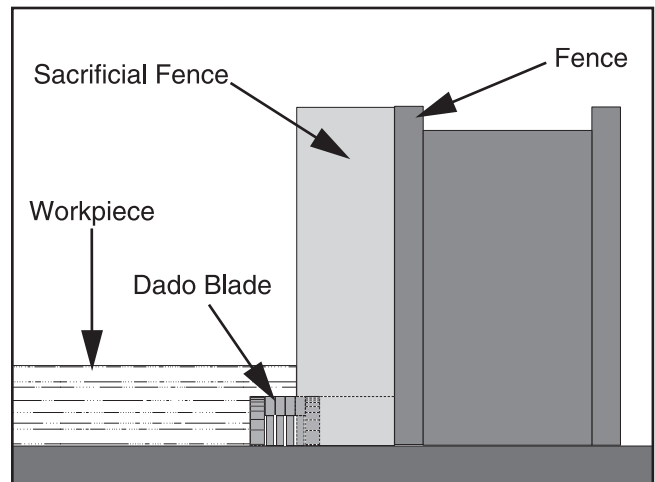

Figure 50. Rabbet cutting.

4. Reconnect the saw to the power source and turn the saw **ON**.
5. When the blade has reached full speed, perform a test cut with a scrap piece of wood.
6. If the cut is satisfactory, repeat the cut with the final workpiece.



**To cut rabbets with the standard blade:**

**Note:** *Cutting rabbets with a standard saw blade DOES NOT require the use of a sacrificial fence.*

**Note:** *Reduce motor overloading and blade wear by using a ripping blade. Ripping blades are designed to clear the sawdust quickly.*

1. DISCONNECT THE SAW FROM POWER!
2. Clearly mark the width of the rabbet cut on the workpiece.

**Note:** *Include marks on the edge of the workpiece to clearly identify the intended cut while it is laying flat on the saw table.*

3. Raise the blade up to the desired depth of cut (depth of rabbet channel desired). When cutting deep rabbets, take more than one pass to reduce the risk of kickback.

**! WARNING**

The danger of kickback increases relative to the depth of a cut. Reduce the risk of kickback by making multiple passes to achieve the desired depth of cut. Failure to follow these warnings could result in serious personal injury.

4. Adjust the fence so the blade is aligned with the inside of your rabbet channel as shown in **Figure 51**.

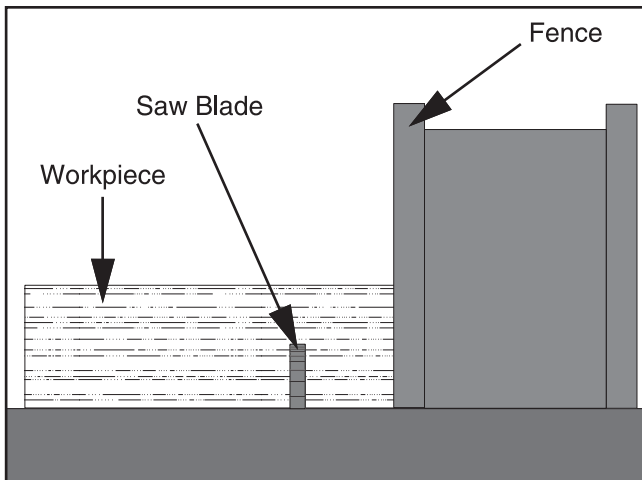

**Figure 51.** Rabbet cutting with a standard blade.

5. Reconnect the saw to the power source and turn the saw **ON**.
6. When the blade has reached full speed, perform a test cut with a scrap piece of wood.
7. If the cut is satisfactory, repeat the cut with the final workpiece.
8. Stand the workpiece on edge as shown in **Figure 52**.

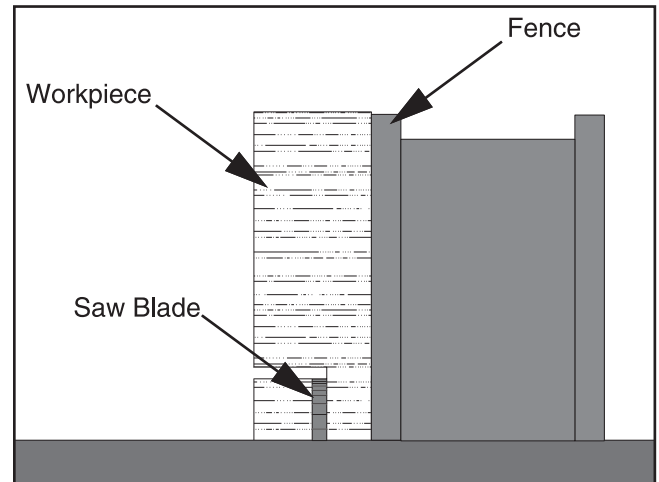

**Figure 52.** Second cut to create a rabbet.

9. Adjust the saw blade height to intersect with the first cut.
10. Perform the second cut to complete the rabbet.



# Resawing

## ⚠️ WARNING

Resawing on a table saw increases the chances of kickback. Serious injury can be caused by kickback. Kickback is a high-speed expulsion of stock from the tablesaw toward an operator. The operator or bystanders may be struck by flying stock, or the operator's hands can be pulled into the blade during the kickback.

## ⚠️ WARNING

Resawing operations require proper procedures to avoid serious injury. Extra care must be taken to prevent kickback when resawing. Any tilting or movement of the workpiece away from the fence will cause kickback. Be certain that stock is flat and straight. Failure to follow these warnings could result in serious personal injury.

Resawing is the process of cutting a thick piece of stock into one or more thinner pieces. **Bandsaws are ideal for resawing and the process is fairly easy and safe. A table saw is not intended for resawing and the process is difficult and extremely dangerous.** Resawing on the table saw often binds the blade, causing kickback. The risk of kickback increases relative to the depth of a cut. Kickback is more dangerous when resawing on a table saw because the anti-kickback devices and blade guard must be removed, leaving no protection between your hands and the saw blade. Kickback can pull the operator's hands into the blade, or the operator or bystanders may be hit by flying stock. **DO NOT** resaw on a table saw without using a resaw barrier. **DO NOT** resaw on a table saw without wearing a full face shield.

The following instructions describe how to build a resaw barrier, add an auxiliary fence to your standard fence, and safely perform resawing operations.

**Note:** This table saw can only resaw wood that is less than 6" tall.

## Resaw Barrier

The resaw barrier shown in **Figure 53** holds the workpiece vertical, keeps the workpiece aligned with the fence, and keeps your hands away from the blade.

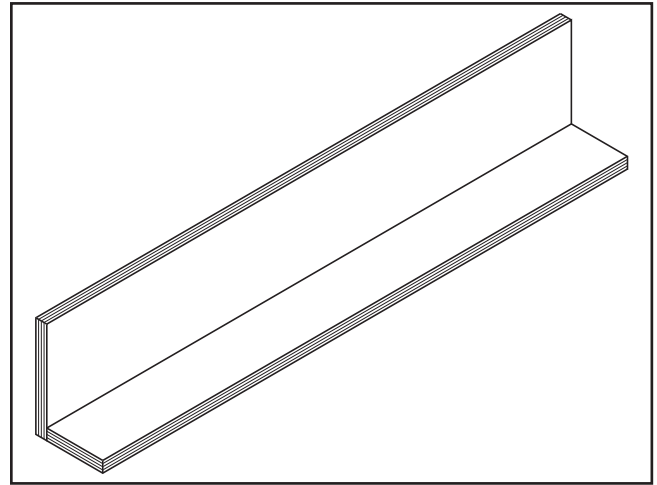

Figure 53. Resawing barrier.

### Components Needed for the Resaw Barrier:

Hardwood or Plywood $\frac{3}{4}$ " x $5\frac{1}{2}$ " x 27"	..... 1
Hardwood or Plywood $\frac{3}{4}$ " x 3" x 27"	..... 1
Wood Screws 2"	..... 8
Wood Glue	..... As Needed

### Tools Needed for the Resaw Barrier:

Table Saw	..... 1
Jointer and Planer	..... Recommended
Clamps	..... 2 Minimum
Drill and Drill Bits	..... 1

### To build the resaw barrier:

1. Cut two boards to  $\frac{3}{4}$ " x  $5\frac{1}{2}$ " x 27" and  $\frac{3}{4}$ " x 3" x 27". If you are using hardwood, cut the boards oversize, then joint and plane the boards to the correct size to make sure the boards are square and flat.

**Note:** Only use furniture grade plywood or kiln dried hardwood to prevent warping.

2. Pre-drill and countersink 8 holes approximately  $\frac{3}{8}$ " from the bottom of the  $5\frac{1}{2}$ " tall board.



3. Glue the end of the 3" board, then clamp the boards at a 90° angle with the larger board in the vertical position as shown in **Figure 54**.

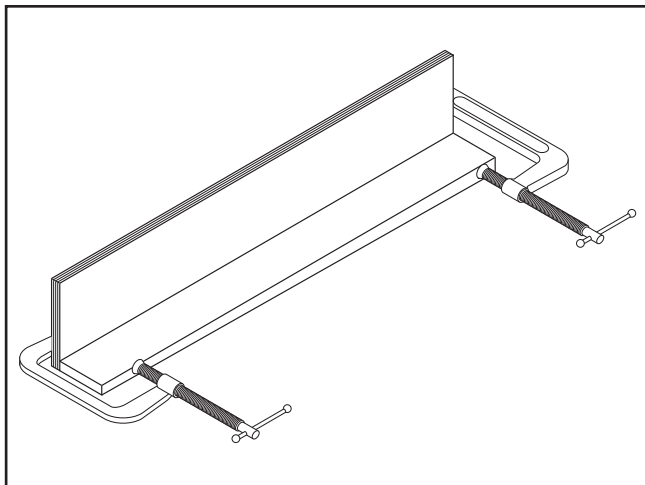

**Figure 54.** Clamping the resawing barrier.

4. Secure the joint with the wood screws.

### Auxiliary Fence

The auxiliary fence is necessary if you are resawing wood that is more than 3" tall. It should be no less than 1/2" shorter than the board to be resawn.

#### Components Needed for the Auxiliary Fence:

Hardwood or Plywood 3/4" x (Height) x 27" .....	1
Flat Head Screws 1/4-20" x 1" .....	8
Hex Nuts 1/4-20" .....	8

#### Tools Needed for the Resaw Barrier:

Table Saw .....	1
Jointer and Planer .....	Recommended
Clamps .....	2 Minimum
Drill and Drill Bits .....	1

#### To build the auxiliary fence:

1. Cut a 3/4" thick board 27" long, and cut a height no less than 1/2" shorter than the board to be resawn. If you are using hardwood, cut the board oversize, then joint and plane the board to the correct size to make sure the board is square and flat.

**Note:** Only use furniture grade plywood or kiln dried hardwood to prevent warping.

2. Pre-drill and countersink 8 holes 1 1/4" from the bottom of the board.

3. Pull an end cap off of the standard fence, then slide the hex nuts into the T-slot and replace the end cap.
4. Thread the flat head screws through the auxiliary fence and into the hex nuts in the standard fence, and tighten securely as shown in **Figure 55**.

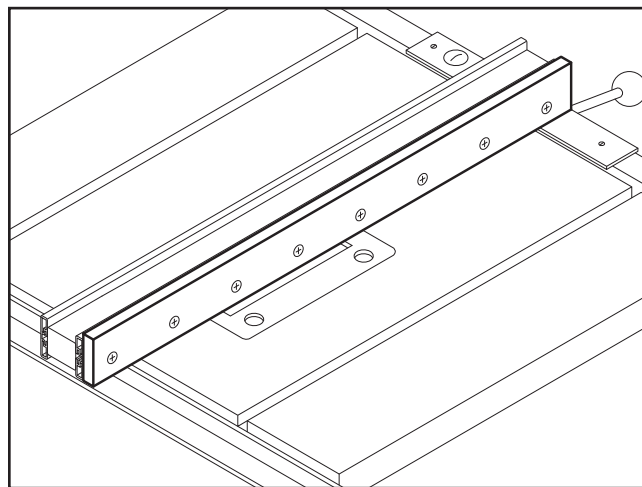

**Figure 55.** Auxiliary fence.

### Resawing Operations

The table saw motor is pushed to its limits when resawing. If the motor starts to bog down, slow down your feed rate. Motor overloading and blade wear can be reduced by using a ripping blade. Ripping blades are designed to clear the sawdust quickly.

#### Components Needed for Resawing:

Zero Clearance Insert.....	1
Ripping Blade 10".....	1
Clamps .....	2
Shop Made Auxiliary Fence .....	1
Shop Made Resaw Barrier .....	1

## **!WARNING**

**You may experience kickback during this procedure. Stand to the side of the blade and wear a full face shield to prevent injury when resawing.**



### To perform resawing operations:

1. DISCONNECT THE SAW FROM POWER!
2. Remove the standard table insert and the blade guard/splitter. Install a ripping blade and a zero clearance table insert. Then lower the blade below the table surface.
3. Attach the auxiliary fence to the standard fence and set it to the desired width.  
  
**Note:** Account for blade kerf, the rough cut made by the blade, and the inaccuracy of the fence scale when the auxiliary fence is installed when figuring out the correct width.
4. Place the workpiece against the fence and slide the resaw barrier against the workpiece. Now clamp the resaw barrier to the top of the table saw (see **Figure 56**).
5. Slide the workpiece over the blade to make sure it moves smoothly.
6. Raise the blade approximately an inch, or close to half the height of the workpiece (**Figure 56**), whichever is less.

## **!WARNING**

The danger of kickback increases relative to the depth of a cut. Reduce the risk of kickback by making multiple passes to achieve the desired depth of cut. Failure to follow these warnings could result in serious personal injury.

## **!CAUTION**

Always use push sticks or push paddles to increase safety and control during operations which require that the blade guard and splitter must be removed from the saw. **ALWAYS** replace the blade guard after resawing is complete.

7. Plug in the table saw, turn it **ON**, and use a push stick to feed the workpiece through the blade using a slow, steady feed rate.
8. Flip the workpiece end for end, keeping the same side against the fence, and run the workpiece through the blade.
9. Repeat **Steps 6–8** until the blade is close to half of the height of the board to be resawn. The ideal completed resaw cut will leave an  $\frac{1}{8}$ " connection when the resawing is complete as shown in **Figure 56**. Leaving an  $\frac{1}{8}$ " connection will reduce the risk of kickback.

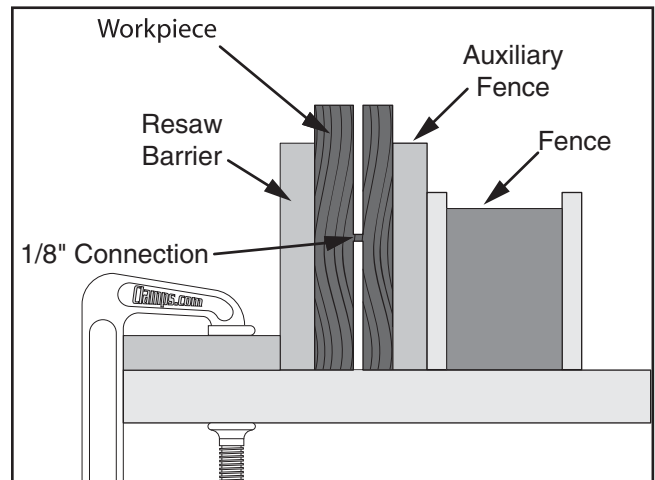

**Figure 56.** Ideal completed resaw cut.

10. Turn **OFF** the table saw, then separate the parts of the workpiece and hand plane the remaining ridge.
11. When finished resawing, remove the resaw barrier and re-install the blade guard/splitter.



# SECTION 5: ACCESSORIES

## G7895—Citrus Degreaser

This citrus based degreaser is perfect for cleaning cosmoline off of new equipment. It also works for cleaning auto parts, tools, concrete, and porcelain surfaces. Natural, safe for the environment, and contains no CFC's.



Figure 57. G7895 Citrus Degreaser.

## G7314—Heavy-Duty SHOP FOX® Mobile Base G8684—Mobile Base Ext. Kit for G1023SLX

Make your machine mobile with this popular patented mobile base. The unique outrigger type supports increase stability and lower machine height. This heavy duty mobile base is rated for up to a 600 lb. capacity.

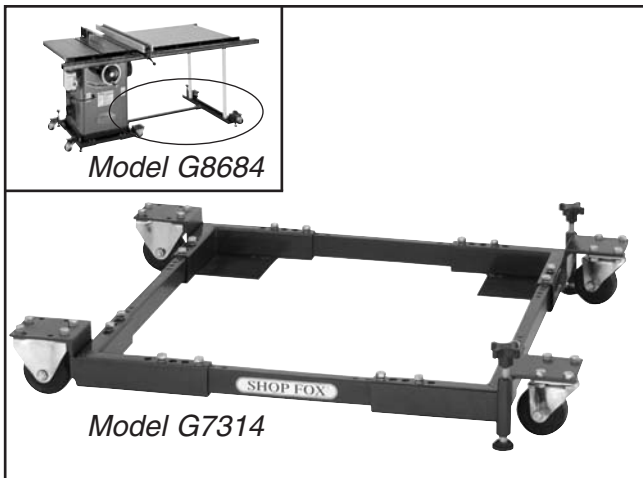

Figure 58. G7314 SHOP FOX® Mobile Base.

## H1234—Table Saw Bench Guide

Like having a master woodworker by your side. Inside this book you'll find great ideas for dozens of shop-made accessories and jigs, in-depth maintenance procedures, loads of safety tips and tricks, and picture-laden walkthroughs for nearly every cut imaginable. Also includes a blade section that covers selection, sharpening, care, troubleshooting, etc. A must have! 160 pages.

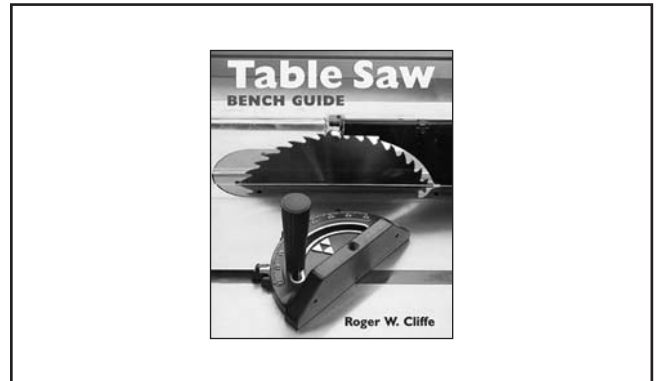

Figure 59. H1234 Table Saw Bench Guide.

## G1316—15" Wide Outfeed Roller System G1317—37" Wide Outfeed Roller System

These unique roller systems fold down easily without tools and snap up in place quickly when needed. Both units have a double level system which lets you set the rollers either in line with the table or slightly below it.



Figure 60. Outfeed roller system.

Call 1-800-523-4777 To Order



- G7984—Face Shield**
- H1298—Dust Sealed Safety Glasses**
- H1300—UV Blocking, Clear Safety Glasses**
- H2347—Uvex® Spitfire Safety Glasses**
- H0736—Shop Fox® Safety Glasses**

Safety Glasses are essential to every shop. If you already have a pair, buy extras for visitors or employees. You can't be too careful when it comes to shop safety!



**Figure 61.** Our most popular safety glasses.

- H2499—Small Half-Mask Respirator**
- H3631—Medium Half-Mask Respirator**
- H3632—Large Half-Mask Respirator**
- H3635—Disposable Cartridge Filter Pair P100**

Wood dust is now considered a known carcinogen and has been linked to nasal cancer and severe respiratory illnesses. If you work around dust everyday, a half-mask respirator can be a lifesaver. Also compatible with safety glasses!



**Figure 62.** Half-mask respirator and disposable cartridge filters.

**Call 1-800-523-4777 To Order**

- Carbide-Tipped Saw Blades (ATB)**
- G4803—10" General Purpose, 30T**
- G4804—10" General Purpose, 40T**
- G4805—10" Fine Finishing/Cabinet Work, 60T**
- G4806—10" Cabinet Work/Trimming, 80T**
- G4807—10" Super Fine Work/Trimming, 100T**

These ATB blades are manufactured to close tolerances and are fully balanced before leaving the factory. All the carbide-tipped teeth are precisely ground to give a smooth cut every time. The pattern of the teeth is alternate top bevel and the saw kerf is approx. 1/8". These blades have proven themselves in thousands of cabinet shops around the country. Manufactured for heavy-duty use.



**Figure 63.** Carbide-tipped saw blades.

**H7777—Grizzly 8" Stack Dado Set**

Finally, a stack dado set that everyone can afford! The set includes two 1/8" wide 30 tooth blades, four 1/8" wide chip cutters, one 3/32" wide chip cutter, one 1/16" wide chip cutter and two each copper shims in .005", .010", .015" and .020" thicknesses. Bore is 5/8". Can cut dados from 1/8" to 3/4".



**Figure 64.** H7777 Grizzly stack dado set.



- G5562—SLIPIT® 1 Qt. Gel
- G5563—SLIPIT® 12 oz Spray
- G2871—Boeshield® T-9 12 oz Spray
- G2870—Boeshield® T-9 4 oz Spray
- H3788—G96® Gun Treatment 12 oz Spray
- H3789—G96® Gun Treatment 4.5 oz Spray



Figure 65. Recommended products for protecting your cast iron table top.

**G3445—Precision Saw Tool**

This high impact plastic Saw Aid™ quickly measures blade height and angle and can also serve as a solid push stick. Includes a graduated ruler guide and center finder.

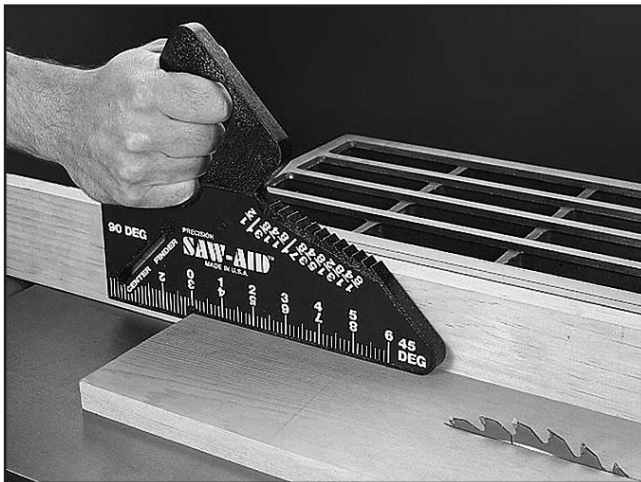

Figure 66. G3445 Precision Saw Tool.

**H7583—Grizzly Tenoning Jig**

Our fully adjustable tenoning jig handles stock up to 3¼" thick and features an adjustable bevel angle with a 90° to 75° range. The two large grip handles, adjustable guide bar, multi-position control levers, and extra large clamping handwheel will ensure accurate and repeatable results. A top seller!

**H3309—SHOP FOX® Featherboard**

Designed to lock into a standard 3/8" x 3/4" miter slot, this featherboard is fully adjustable to accommodate a wide range of workpieces. Reduce the likelihood of kickback with this convenient accessory.



Figure 67. H3309 SHOP FOX® Featherboard.

**G2370—SHOP FOX® Board Buddies**

These unique hold downs only turn in one direction to prevent kickback. Adjustable height, spring loaded wheels are designed to hold your workpiece tight against the table and rip fence and are made of a special composition that will not mark your work.



Figure 68. G2370 SHOP FOX® Board Buddies.

**Call 1-800-523-4777 To Order**



### H3308—SHOP FOX® Push Stick

Measuring 13½" overall, this push stick allows the operator to keep their hands at a safe distance away from the blade or cutter.

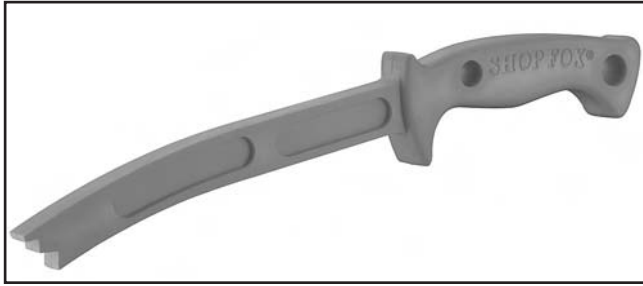

Figure 69. H3308 SHOP FOX® Push Stick.

### H4231—Zero-Clearance Table Insert

Made from special phenolic material, these inserts reduce the risk of kickback and increase dust collection efficiency.

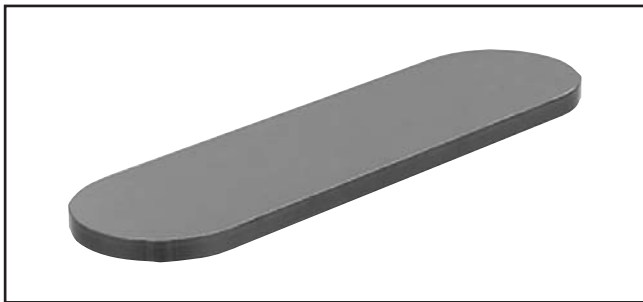

Figure 70. H4231 Zero-Clearance Table Insert.

### H4332—T4 Silencer for Saw Blades

Woodworkers across the country swear by these blade silencers. For a fraction of the price of a new saw blade, the T4 Silencer eliminates vibration, dampens noise and stabilizes any blade, allowing it to cut more accurately, smoothly and quietly. A great companion for any blade!



Figure 71. T4 saw blade silencer.

### H3771—Blade Loc®

This simple tool secures the blade during blade changes, keeping your hands and your expensive blade from being damaged.



Figure 72. H3771 Blade Loc®.

### G7581—Superbar™

### G7582—Master Plate

The miter slot mounted Superbar™ will align, tune and calibrate your tablesaw to within ±.001 in just minutes. Replace your tablesaw blade when calibrating the double disk ground Master Plate for a precision measurement, with no runout!

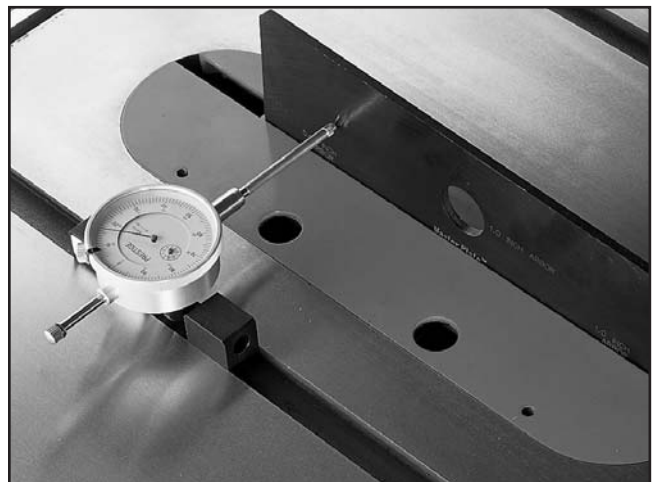

Figure 73. Superbar™ and Master Plate.

### G3639—Power Twist Link V-Belts

Replace the standard V-belts with these and enjoy a smoother, quieter machine with less vibration. These V-belts are easily customizable by adding or removing links, and they will greatly outlast standard V-belts. Sold in 48" lengths. Requires two lengths to replace the three standard V-belts on your table saw. You'll be so impressed that you'll want these on every machine in your shop!

Call 1-800-523-4777 To Order



# SECTION 6: MAINTENANCE

---

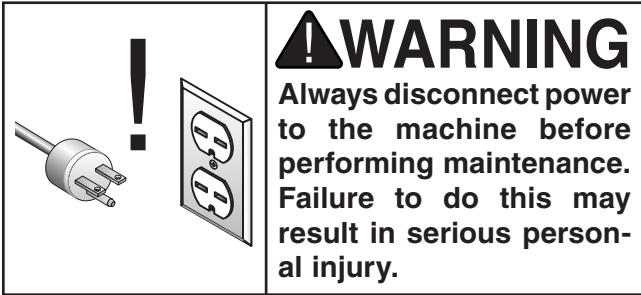

## Schedule

---

For optimum performance from your machine, follow this maintenance schedule and refer to any specific instructions given in this section.

### Daily

- Check guard alignment and operation.
- Inspect blades for damage or wear.
- Check for loose mounting bolts/arbor nut.
- Check cords, plugs, and switch for damage.
- Any other condition that could hamper the safe operation of this machine.
- Vacuum dust buildup from inside the cabinet and off of the motor after use.
- Wipe the table clean after every use—this ensures moisture from wood dust does not remain on bare metal surfaces.

### Weekly

- Wipe down the table surface and grooves with a lubricant and rust preventive such as SLIPIT®.
- Clean the pitch and resin from the saw blade with a cleaner like OxiSolv® Blade & Bit Cleaner.

### Monthly

- Check the V-belt for damage or wear.

## Cleaning

---

Cleaning the table saw is relatively easy. Vacuum excess wood chips and sawdust, and wipe off the remaining dust with a dry cloth. If any resin has built up, use a resin dissolving cleaner to remove it. Treat all unpainted cast iron and steel with a non-staining lubricant after cleaning.

Occasionally it will become necessary to clean the internal parts with more than a vacuum. To do this, remove the table top and clean the internal parts with citrus cleaner or mineral spirits and a stiff wire brush or steel wool. **DO NOT USE WATER—WATER WILL CAUSE CAST IRON TO RUST.** Make sure the internal workings are dry before using the saw again, so that wood dust will not accumulate. If any essential lubrication is removed during cleaning, re-lubricate those areas.

## Lubrication

---

Lubricate the areas indicated below every 6–12 months, depending on frequency of use.

1. **Blade angling trunnions.** These should be lubricated with 6 or 7 drops of light machine oil.
2. **Blade height trunnion.** This should also be lubricated with 6 or 7 drops of light machine oil.
3. **The 2 worm gears** should be lubricated with an automotive wheel bearing grease.

These points can be reached through the motor cover opening or the blade opening. Check all adjustments after lubricating.



# SECTION 7: SERVICE

This section is provided for your convenience—it is not a substitute for the Grizzly Service Department. If you need help troubleshooting, you need replacement parts, or you are unsure of how to perform the procedures in this section, then feel free to call our Technical Support at (570) 546-9663.

## Troubleshooting

### Motor & Electrical

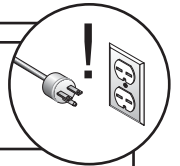

SYMPTOM	POSSIBLE CAUSE	CORRECTIVE ACTION
Machine does not start or a breaker trips.	<ol style="list-style-type: none"> <li>1. Plug or receptacle is at fault or wired incorrectly.</li> <li>2. Cable or wiring is open or has high resistance.</li> <li>3. The thermal overload relay below the motor contactor is tripped.</li> <li>4. Wall fuse or circuit breaker is blown or tripped.</li> <li>5. Motor connection is wired incorrectly.</li> <li>6. Power supply is faulty, or is switched <b>OFF</b>.</li> <li>7. Start capacitor is faulty.</li> <li>8. Motor ON button.</li> <li>9. Centrifugal switch is at fault.</li> <li>10. Contactor not getting energized or has burnt contacts.</li> <li>11. Motor is damaged.</li> </ol>	<ol style="list-style-type: none"> <li>1. Test power plug and receptacle for good contact and correct wiring.</li> <li>2. Troubleshoot wires for internal or external breaks, and disconnected or corroded connections; repair or replace wiring.</li> <li>3. Reset overload relay. If it continues to trip, turn up the dial to a higher shut-off amperage.</li> <li>4. Make sure circuit breaker/fuse is sized correctly for machine load (refer to <b>Page 11</b>), or replace weak breaker.</li> <li>5. Correct motor wiring.</li> <li>6. Make sure all hot lines and grounds are operational and have correct voltage.</li> <li>7. Replace start capacitor.</li> <li>8. Replace faulty ON button.</li> <li>9. Adjust or repair centrifugal switch.</li> <li>10. Replace contactor.</li> <li>11. Repair or replace motor.</li> </ol>
Machine stalls or is underpowered.	<ol style="list-style-type: none"> <li>1. Applying too much pressure to workpiece.</li> <li>2. Low power supply voltage.</li> <li>3. Belt is slipping.</li> <li>4. Plug or receptacle is at fault.</li> <li>5. Motor connection is wired incorrectly.</li> <li>6. Pulley or sprocket is slipping on shaft.</li> <li>7. Motor has overheated.</li> <li>8. Motor bearings are at fault.</li> <li>9. Run capacitor is faulty.</li> <li>10. Contactor not getting energized or has poor contacts.</li> <li>11. Motor is at fault.</li> <li>12. Centrifugal switch is at fault.</li> </ol>	<ol style="list-style-type: none"> <li>1. Use sharp blade, and reduce the feed rate.</li> <li>2. Make sure all hot lines and grounds are operational and have correct voltage.</li> <li>3. Replace belt and/or re-tension.</li> <li>4. Test power plug and receptacle for good contact and correct wiring.</li> <li>5. Correct motor wiring.</li> <li>6. Replace loose pulley and shaft.</li> <li>7. Let motor cool, clean motor fan cover, and reduce workload on machine.</li> <li>8. Rotate motor shaft for noisy or burnt bearings, replace as required.</li> <li>9. Replace run capacitor.</li> <li>10. Replace contactor.</li> <li>11. Repair or replace motor.</li> <li>12. Repair or replace centrifugal switch.</li> </ol>



<b>SYMPTOM</b>	<b>POSSIBLE CAUSE</b>	<b>CORRECTIVE ACTION</b>
Machine has vibration or noisy operation.	<ol style="list-style-type: none"> <li>1. Loose arbor nut.</li> <li>2. Blade is damaged.</li> <li>3. Blade is too thin.</li> <li>4. Machine is sitting on an uneven floor.</li> <li>5. Belt is worn or is loose.</li> <li>6. Pulley is loose.</li> <li>7. Wrong workpiece material (wood).</li> <li>8. Cast iron motor mount is damaged.</li> <li>9. Arbor bearings are damaged.</li> <li>10. Motor bearings are damaged.</li> </ol>	<ol style="list-style-type: none"> <li>1. Tighten the arbor nut.</li> <li>2. Replace warped/ bent/ or twisted blade;.</li> <li>3. Use blade stabilizers.</li> <li>4. Relocate machine or shim feet.</li> <li>5. Inspect belt, replace or re-tension.</li> <li>6. Remove pulley; replace shaft, pulley, and set screw as required, and re-align.</li> <li>7. Only cut wood with correct moisture content, with no pitch, glues, or resins.</li> <li>8. Carefully using leverage and a small pry bar, carefully look for loose/broken mounts and replace if necessary.</li> <li>9. Replace arbor housing bearings.</li> <li>10. Replace motor bearings.</li> </ol>

## Table Saw Operations

<b>SYMPTOM</b>	<b>POSSIBLE CAUSE</b>	<b>CORRECTIVE ACTION</b>
Blade is not aligned with miter slot or fence.	<ol style="list-style-type: none"> <li>1. Blade is warped.</li> <li>2. Blade is not parallel to table top.</li> <li>3. Fence is not parallel to blade.</li> </ol>	<ol style="list-style-type: none"> <li>1. Replace blade.</li> <li>2. Make blade parallel to table.</li> <li>3. Make fence parallel to blade.</li> </ol>
Fence hits table top when sliding.	<ol style="list-style-type: none"> <li>1. Front rail is bolted too low on table.</li> <li>2. Rear rail is bolted too low on the table.</li> </ol>	<ol style="list-style-type: none"> <li>1. Raise front rail.</li> <li>2. Raise rear rail.</li> </ol>
Blade does not reach 90°.	<ol style="list-style-type: none"> <li>1. 90° stop bolt is out of adjustment.</li> <li>2. Pointer bracket is hitting before the blade reaches 90°.</li> <li>3. Sawdust loaded up on positive stop.</li> </ol>	<ol style="list-style-type: none"> <li>1. Adjust 90° stop bolt.</li> <li>2. File down the right side of the pointer bracket until the blade can reach 90°.</li> <li>3. Clean sawdust off positive stop.</li> </ol>
Blade hits insert at 45°.	<ol style="list-style-type: none"> <li>1. Hole in insert is inadequate.</li> <li>2. Table out of alignment.</li> <li>3. Blade position is incorrect.</li> </ol>	<ol style="list-style-type: none"> <li>1. File or mill the hole in the insert.</li> <li>2. Align blade to the table.</li> <li>3. Adjust blade position.</li> </ol>
Blade will not go beneath table surface.	<ol style="list-style-type: none"> <li>1. Table top too low.</li> </ol>	<ol style="list-style-type: none"> <li>1. Lower the blade trunnion w/washers.</li> </ol>
Board binds or burns when feeding through tablesaw.	<ol style="list-style-type: none"> <li>1. Dull blade.</li> <li>2. Blade is warped.</li> <li>3. Splitter out of alignment.</li> <li>4. Fence is not parallel to blade.</li> <li>5. Table top is not parallel to blade.</li> </ol>	<ol style="list-style-type: none"> <li>1. Replace blade.</li> <li>2. Replace blade.</li> <li>3. Align the splitter with the blade.</li> <li>4. Make fence parallel to blade.</li> <li>5. Make table parallel to blade.</li> </ol>



# Blade Tilt Stops

The table saw trunnion features 45° and 90° stop bolts on the geared trunnion that, when adjusted correctly, stop the blade exactly at 45° and 90° during blade adjustments.

## To set the stop bolts on the trunnion:

1. DISCONNECT SAW FROM POWER!
2. Position the blade tilt to zero (see indicator on the front of the saw), and raise the blade several inches above the table.
3. Place a machinist's square flat on the table and slide it alongside the blade. The square should contact the blade evenly from bottom to top. Make sure that a blade tooth does not obstruct the movement of the square.

4. Adjust the handwheel until the square is flush with the blade. Loosen the tilt indicator arrow, set to zero, and retighten. Loosen and adjust the stop bolt on the left side of the front trunnion to allow a 90° stop point. See **Figure 74** for details.

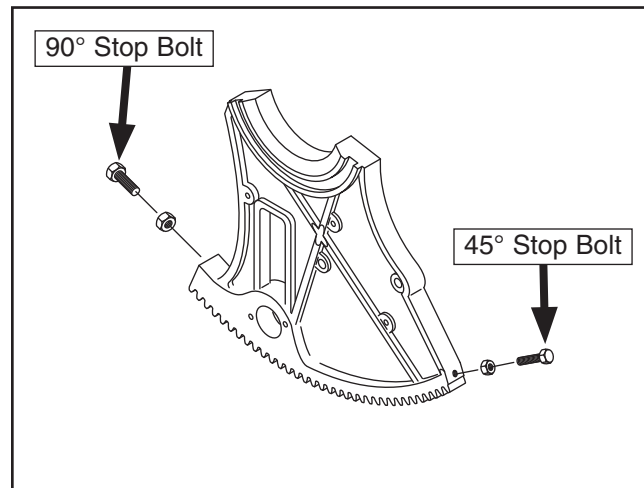

**Figure 74.** Geared trunnion.

5. Turn the blade angle handwheel until the angle indicator points at the desired angle.
6. Tighten the handwheel locking knob.
7. Repeat **Steps 1-6** for setting the blade to 45° and adjust the 45° stop bolt on the right side of the front trunnion. Use the 45° side of a combo square or a bevel gauge set at 45°.



# Miter Slot to Blade

Your table saw will give the best results if the miter slot and the rip fence are adjusted parallel to the blade. If either of these are not exactly parallel, your cuts and your finished work will be lower in quality, but more important, this condition increases the risk of kickback. Take the time to adjust your table saw properly. A few minutes now will be time well spent.

**Note:** For safest and most accurate adjustments, use a Superbar and Master plate (see **Figure 73** on **Page 44**).

1. DISCONNECT SAW FROM POWER!
2. Use an adjustable square to measure the distance from the miter slot to a carbide tip on the blade as shown in **Figure 75**. Make sure that the face of the adjustable square is even along the miter slot.

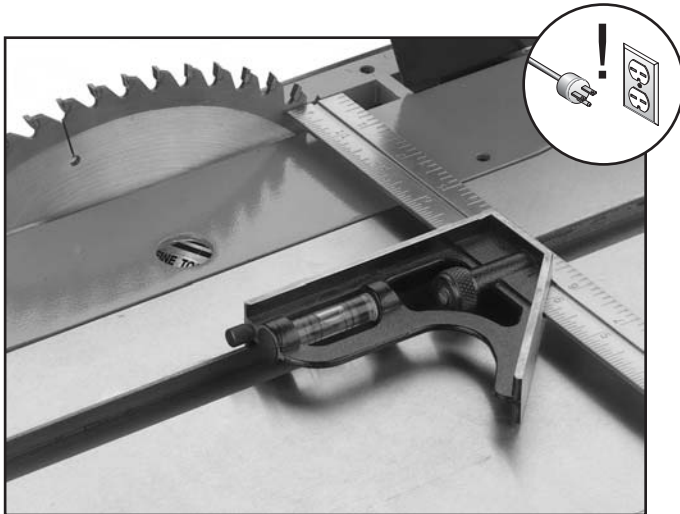

**Figure 75.** Adjusting blade to miter slot.

3. With the end of the adjustable square just touching the tip, lock the square in place. Now, mark the carbide tip with a magic marker where you made this measurement.
4. Rotate that tip to the other end of the table insert.
5. Slide the adjustable square down to the other end of the table insert, and compare the distance from the marked blade tip to the end of the adjustable square.

6. If the blade tip does not touch the end of the adjustable square similar to the first measurement, then the table will need to be adjusted.
7. To adjust the table, loosen the four bolts in the table mounting locations (see **Figure 76**) and slightly tap the table. Repeat **Steps 2-6** until satisfactory. Do not forget to tighten the table mounting bolts when finished.

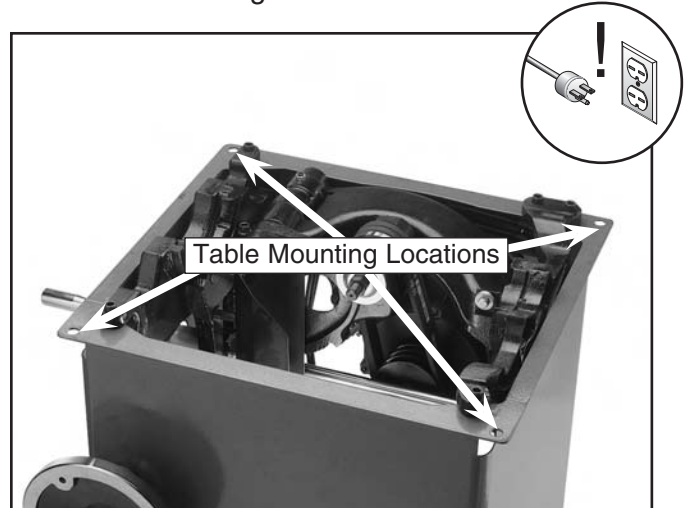

**Figure 76.** Table mounting bolt holes.

8. Now check to see if the blade remains parallel to the miter slot when tilted to 45°.
9. Tilt the blade to 45° and repeat **Steps 2-6**. If the blade is still parallel to the miter slot, continue on to the **Miter Gauge** instructions. Otherwise, continue with the next step.
10. If the blade was parallel to the miter slot at 90° but not at 45°, the table will need to be shimmed with metal shim stock. The shims are placed under the table over each of the four table mounting bolts.

## **!**WARNING

The saw blade is dangerously sharp. Use extra care when handling the blade or working near it. Serious injury is possible.



11. Refer to **Figures 77 and 78**, for shim placement. If the distance of A is shorter than B, shim(s) will need to be placed under corners #1 and #2. If the distance of B is shorter than A, shim(s) will need to be placed under corners #3 and #4. Very thin shim stock works well—just make sure they are all the same thickness, and you put an equal number under each of the two corners.
12. Tighten down one bolt a small amount and then move on to each of the others, tightening each down the same amount. Continue to rotate through the bolts, tightening them a little each time until they are all secure.
13. Now recheck the blade to miter slot at 90° and 45° by repeating **Steps 2-6**. If the distance of A and B are equal, continue to the **Miter Gauge** instructions. If the distances are still off, repeat **Steps 10-13**.
14. Once you feel you have the miter slot adjusted to the blade, recheck all measurements and be sure the table mounting bolts are secure. Repeat **Step 10** in **Blade Guard/Splitter**. Also, if you ever remove the table in the future, be sure to make note of shim placements and reassemble exactly how it came apart.

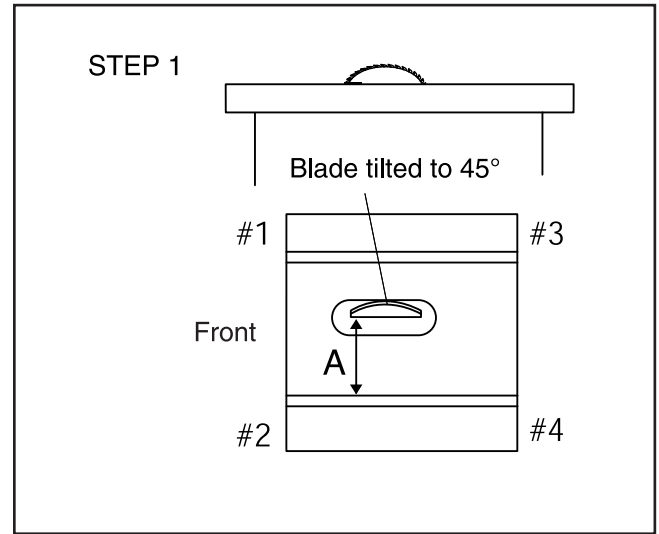

**Figure 77.** Shim procedure diagram A.

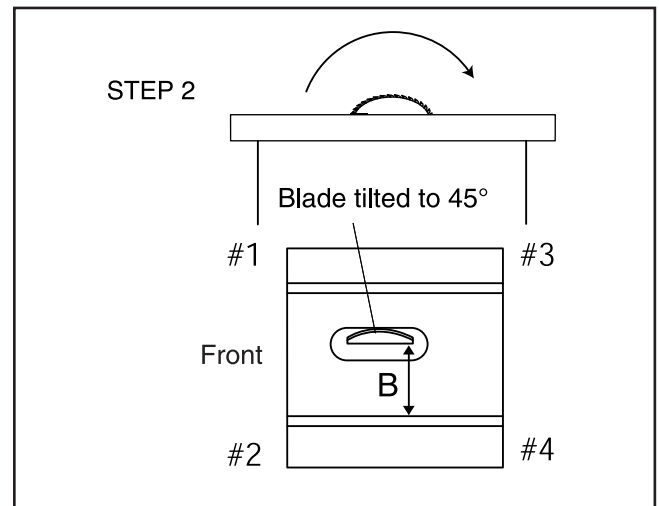

**Figure 78.** Shim procedure diagram B.



# Blade Alignment

The blade position can be adjusted slightly in case it contacts the table insert when raised or tilted. This adjustment can be made either by moving the whole trunnion assembly, or by just moving the arbor bracket. Try adjusting by moving the whole trunnion first, this is the easier of the two ways.

## To adjust the blade position by moving the trunnion:

1. DISCONNECT THE SAW FROM POWER!
2. Remove the table and wings and set them to one side.
3. Loosen the four trunnion mounting bolts as shown in **Figure 79**, and nudge the trunnion to either the left or the right depending on where the blade is hitting the saw.

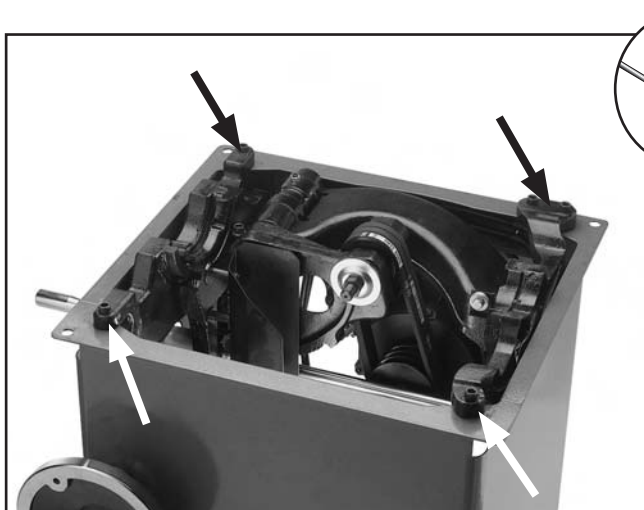

Figure 79. Trunnion mounting bolts.

4. Reattach the table, making sure there is adequate blade clearance through all blade adjustments. Recheck guard alignment to the blade and to the table top. Adjust as necessary and tighten down all the bolts before use.
5. If the blade is still contacting the insert, repeat **Steps 2-4**. Check all other adjustments.
6. Recheck the blade to miter slot adjustments, and adjust as necessary.

## To adjust the blade position by moving the arbor bracket:

1. DISCONNECT THE SAW FROM POWER!
2. Remove the table and wings and set them to one side.
3. Loosen the adjustment bolt shown in **Figure 80**.

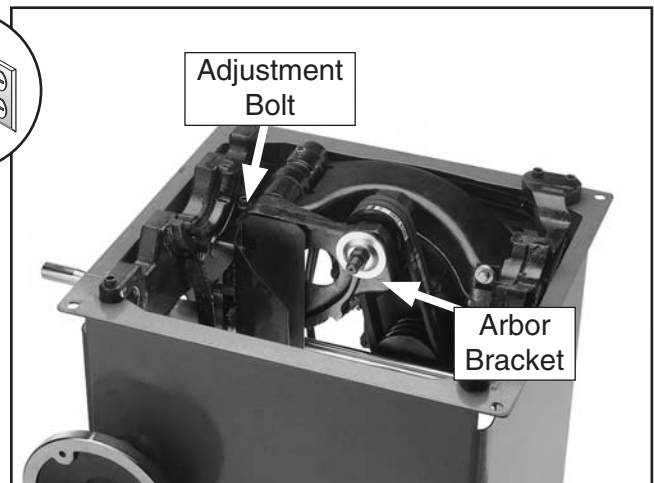

Figure 80. Adjusting arbor bracket.

4. To adjust the arbor bracket, loosen the adjustment bolt. Slowly slide the arbor bracket towards the end of the shaft.

	<p><b>⚠ WARNING</b> The table and wings are very heavy. DO NOT over-exert yourself while lifting or moving the table and wings – get assistance.</p>
---	--

<p><b>NOTICE</b> If you make the adjustment described in this section, check and adjust the blade splitter to make sure it aligns with the blade.</p>
---



5. Moving the arbor bracket moves the V-belts and pulleys out of alignment, so adjustment of the motor pulley is required. Simply loosen the set screw in the middle motor groove pulley and slowly slide the pulley towards the end of the motor shaft. Once the V-belts are back in alignment, tighten the set screw securely.
6. Reattach the table, making sure there is adequate blade clearance through all blade adjustments. Recheck guard alignment to the blade and to the table top. Adjust as necessary and tighten down all the bolts before use.
7. If the blade is still contacting the insert, repeat **Steps 2-6**. Check all other adjustments.
8. Recheck the blade to miter slot adjustments, and adjust as necessary.

## Adjusting Fence

The rip fence included with your G1023SL Series Table Saw is designed to provide excellent ripping accuracy when properly adjusted. For complete adjustment procedures, refer to the manual that is included with the fence.

## Miter Gauge

**To adjust the miter gauge so it is perpendicular to the saw blade:**

1. Loosen the lock knob on the miter gauge and place a square against the face of the miter body and the blade.
2. Adjust the miter body until there is no space between the square and the blade. Tighten the lock knob.
3. With the stop link in the up position, loosen the jam nut and adjust the stop screw until it is seated against the stop link (see **Figure 81** for part locations).
4. Now loosen the set screw on the left front side of the miter bar, adjust the pointer to 90° and tighten the set screw.
5. To adjust to 45°, follow **Steps 1-4** using an adjustable square set to 45°.
6. After rotating the miter body from 45° to 90° and back a few times, double-check your adjustments at both angles to assure that you have accurately set your miter gauge.

The miter bar can be adjusted so that it fits tighter in the miter slot. To do this, turn the adjustment set screw shown in **Figure 81** clockwise in small increments and test fit between adjustments until it fits your expectations.

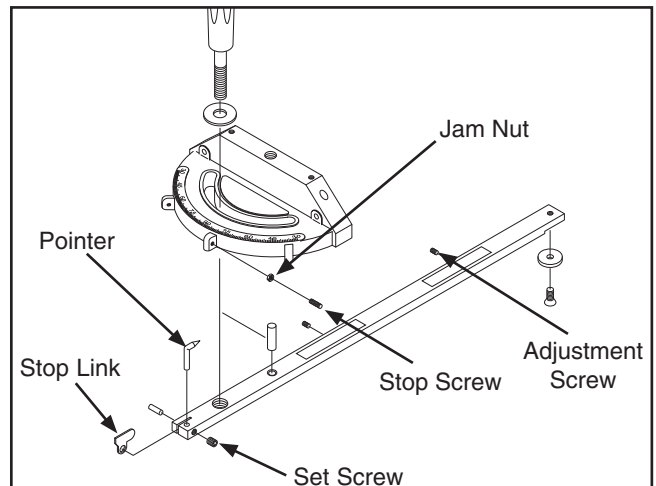

**Figure 81.** Miter gauge diagram.



# G1023SL, SLX, SLW Wiring



## G1023SL G1023SLX G1023SLW

COLOR KEY	
BLACK	— Bk —
GREEN	— Gn —
RED	— Rd —
BLUE	— Bl —

**⚠ DANGER**  
Disconnect power before performing any electrical service. Electricity presents serious shock hazards that will result in severe personal injury and even death!

**1-PHASE  
220 VAC**



**L6-20 PLUG  
(as recommended)**



**MAGNETIC  
SWITCH  
ASSEMBLY**

← Contactor →

← Thermal  
Overload  
Relay →

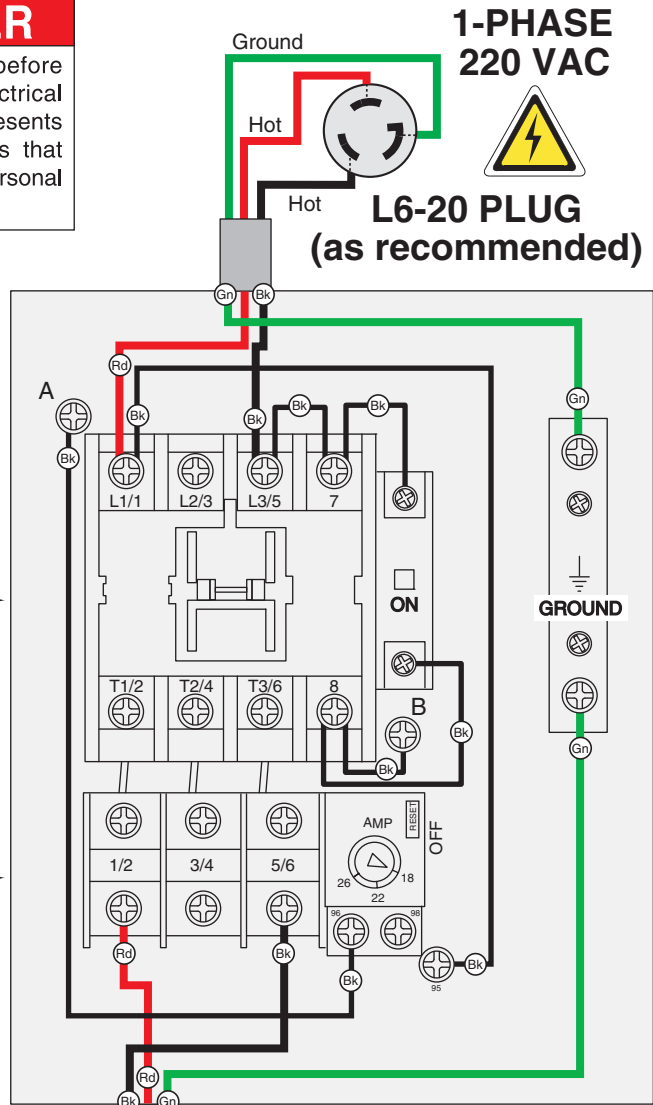

**3HP  
1-PHASE  
220V  
MOTOR**

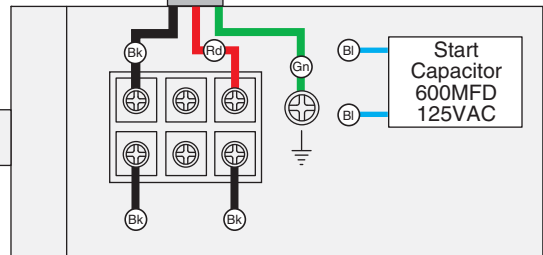

# G1023SLWX Wiring



## G1023SLWX

COLOR KEY	
BLACK	
GREEN	
RED	

**⚠ DANGER**  
 Disconnect power before performing any electrical service. Electricity presents serious shock hazards that will result in severe personal injury and even death!

**1-PHASE  
 220 VAC**

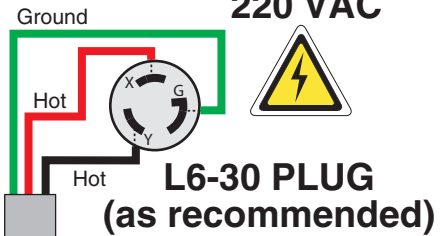

**MAGNETIC SWITCH ASSEMBLY**

← Contactor →

← Thermal Overload Relay →

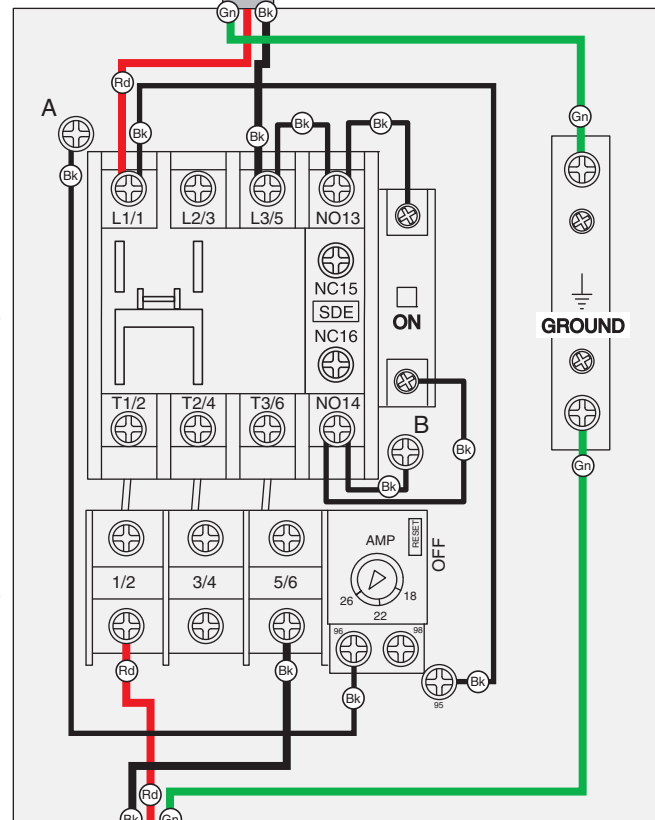

**5HP  
 1-PHASE  
 220V  
 MOTOR**

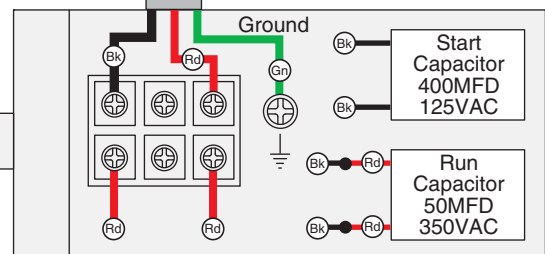

# G1023SLWX3 Wiring



## G1023SLWX3

COLOR KEY	
BLACK	Bk
GREEN	Gn
RED	Rd
WHITE	Wt
BLUE	Bl

**⚠ DANGER**

Disconnect power before performing any electrical service. Electricity presents serious shock hazards that will result in severe personal injury and even death!

**3-PHASE  
440 VAC**

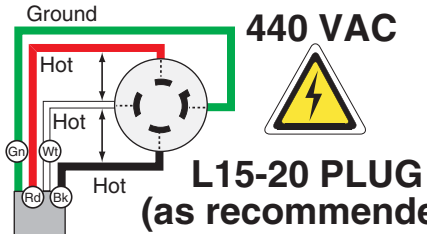

**NOTICE**

If motor rotates in the opposite direction, swap the black or red wires at the power source.

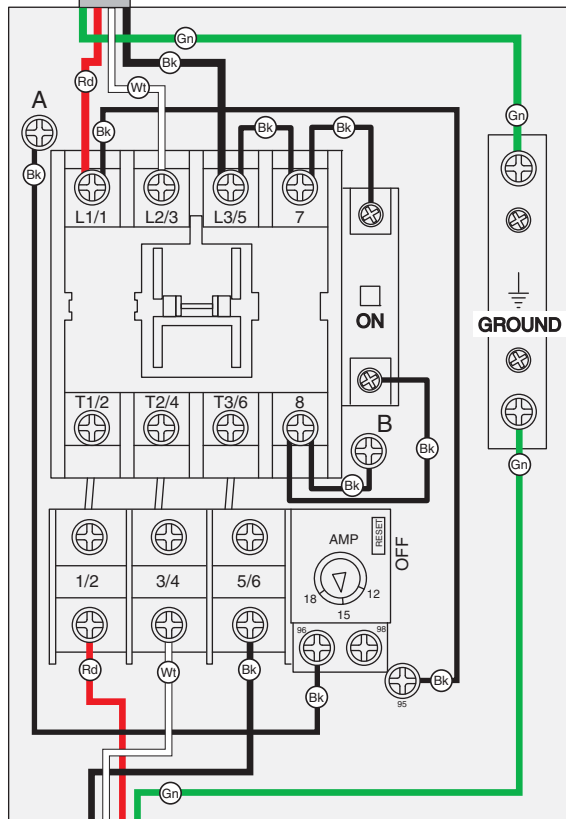

**220V  
MAGNETIC  
SWITCH  
ASSEMBLY**

**440V  
MAGNETIC  
SWITCH  
ASSEMBLY**

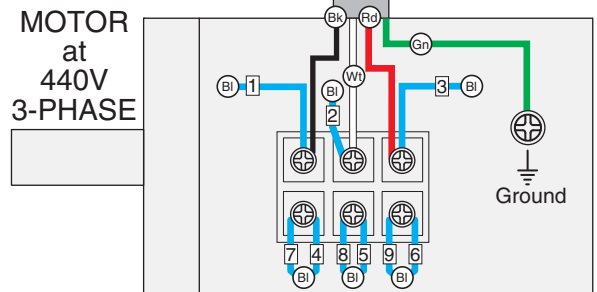
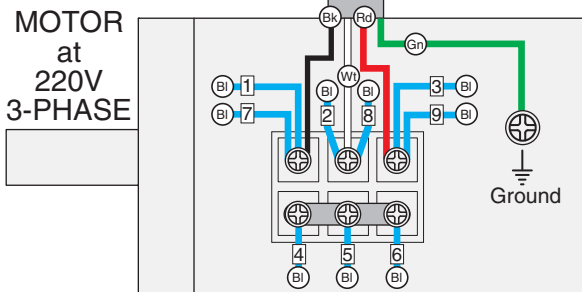
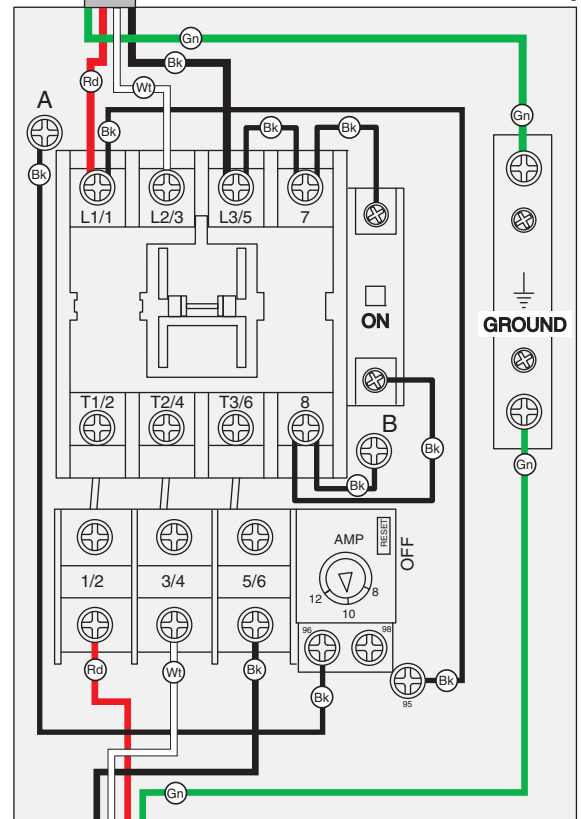

# G1023SL (All) Main Parts

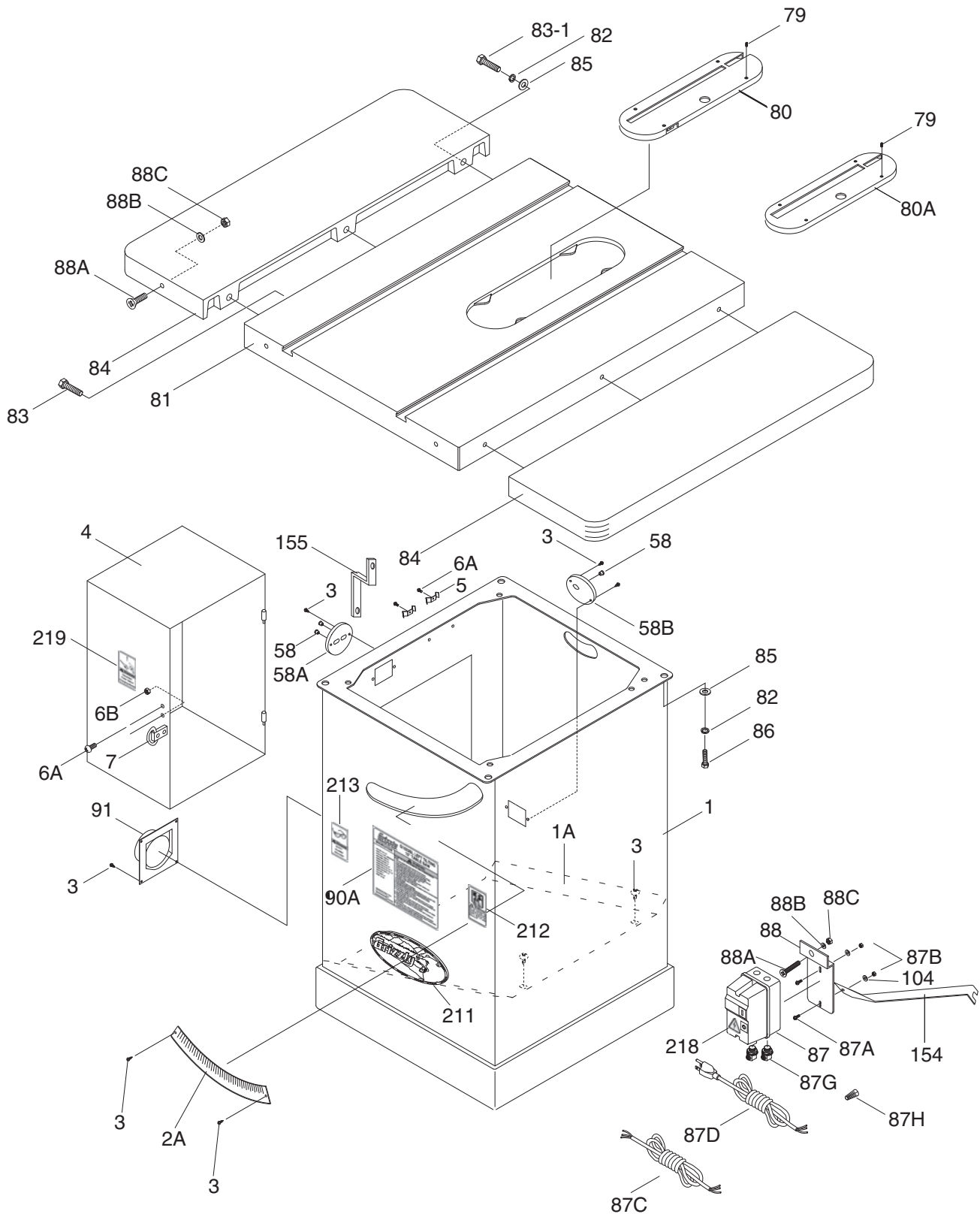

# G1023SL (All) Main Parts

REF	PART #	DESCRIPTION
1	P1023SL001	CABINET
1A	P1023SL001A	LOWER PANEL
2A	P1023SL002A	SCALE
3	PHTEK4	TAP SCREW #10 X 3/8
4	P1023SL004	MOTOR COVER
5	P1023SL005	CORD CLAMP
6A	PS24	PHLP HD SCR #8-32 X 3/8
6B	PN14	HEX NUT #8-32
7	P1023SL007	LATCH
58	P1023SL058	CORD CLAMP
58A	P1023SL058A	CORD CLAMP PLATE
58B	P1023SL058B	CORD CLAMP PLATE
79	PSS07	SET SCREW 1/4-20 X 1/2
80	P1023SL080	STANDARD TABLE INSERT
80A	P1023SL080A	DADO TABLE INSERT
81	P1023SL081	TABLE
82	PLW04	LOCK WASHER 3/8
83	PB24	HEX BOLT 3/8-16 X 1-1/4
83-1	PB18	HEX BOLT 3/8-16 X 1"
84L	P1023SL084L	LEFT EXTENSION WING
84R	P1023SL084R	RIGHT EXTENSION WING
85	PW02	FLAT WASHER 3/8
86	PSB16	CAP SCREW 3/8-16 X 3/4
87	P1023SL087	MAG SWITCH (3HP, 1-PH)
87	P1023SLWX087	MAG SWITCH (5HP, 1-PH)
87	P1023SLWX3087	MAG SWITCH (5HP, 220V, 3-PH)
87S	P1023SLWX3087S	MAG SWITCH (5HP, 440V, 3-PH)
87A	PS31	PHLP HD SCR 10-24 X 1-3/4

REF	PART #	DESCRIPTION
87B	PN07	HEX NUT 10-24
87C	P1023SL087C	MOTOR CORD (G1023SL/X/W)
87C	P1023SLWX087C	MOTOR CORD (G1023SLWX)
87C	P1023SLWX3087C	MOTOR CORD (G1023SLWX3)
87D	P1023SL087D	POWER CORD (G1023SL/X/W)
87D	P1023SLWX087D	POWER CORD (G1023SLWX)
87D	P1023SLWX3087D	POWER CORD (G1023SLWX3)
87G	P1023SL087G	GROMMET
87H	P1023SL087H	WIRE NUT
88	P1023SL088	SWITCH PLATE
88A	PFH25	FLAT HD SCR 5/16-18 X 1"
88B	PW07	FLAT WASHER 5/16
88C	PN02	HEX NUT 5/16-18
90A	P1023SL090A	G1023SL MACHINE ID LABEL
90A	P1023SLX090A	G1023SLX MACHINE ID LABEL
90A	P1023SLW090A	G1023SLW MACHINE ID LABEL
90A	P1023SLWX090A	G1023SLWX MACHINE ID LABEL
90A	P1023SLWX3090A	G1023SLWX3 MACHINE ID LABEL
91	P1023SL091	DUST HOSE ADAPTER
104	PW03	FLAT WASHER #10
154	P1023SL154	SWITCH PLATE BRACE
155	P1023SL155	MOTOR BRACE
211	G8588	LOGO PLATE
212	PLABEL-12A	READ MANUAL LABEL
213	PLABEL-11	SAFETY GLASSES LABEL
218	PLABEL-14	ELECTRICITY LABEL
219	PLABEL-33	UNPLUG TABLE SAW LABEL

## WARNING

Safety labels warn about machine hazards and ways to prevent injury. The owner of this machine **MUST** maintain the original location and readability of the labels on the machine. If any label is removed or becomes unreadable, **REPLACE** that label before using the machine again. Contact Grizzly at (800) 523-4777 or [www.grizzly.com](http://www.grizzly.com) to order new labels.





# G1023SL (All) Arbor/Motor Parts

REF PART #	DESCRIPTION	
8A	P1023SL008A	LOCK KNOB
9B	P1023SL009B	HANDLE
10A	P1023SL010A	HANDWHEEL
11	PSS03	SET SCREW 1/4-20 X 3/8
12	PSB65	CAP SCREW 10-24 X 2"
12A	PLW03	LOCK WASHER #10
13	P1023SL013	POINTER BRACKET
14A	PW07	FLAT WASHER 5/16
14B	PS35	PHLP HD SCR 5/16-18 X 3/8
15A	P1023SL015A	POINTER ADAPTER
15B	PS23	PHLP HD SCR 8-32 x 1/4
15C	P1023SL015C	POINTER
16	P1023SL016	FRNT TRUNNION BRACKET
16A	P1023SL016A	GUIDE BLOCK
16B	PSB05	CAP SCREW 1/4-20 X 3/4
16C	PW06	FLAT WASHER 1/4
17	P1023SL017	SHIELD PLATE
18	PS35	PHLP HD SCR 5/16-18 X 3/4
19	PSB26	CAP SCREW 3/8-16 X 1 1/2
20	PLW04	LOCK WASHER 3/8
21	PN08	HEX NUT 3/8-16
22	PSS03	SET SCREW 1/4-20 X 3/8
23	P1023SL023	WORM GEAR
24	P1023SL024	COLLAR
25	PSS05	SET SCREW 5/16-18 X 1/4
26	P1023SL026	TILT SHAFT
26A	P1023SL026A	BRASS WASHER 3/4
27	P1023SL027	PIN
27A	P1023SL027A	BEARING LOAD SPRING
28	PK02M	KEY 5 X 5 X 40
29A	P1023SL029A	GEARED TRUNNION
29B	P1023SL029B	BUSHING
30	PN02	HEX NUT 5/16-18
30A	PSB08	CAP SCREW 5/16-18 X 1-1/2
30B	P1023SL030B	SPACER
31	PB03	HEX BOLT 5/16-18 X 1
32	P1023SL032	FLANGE
33	P1023SL033	SHAFT
35A	P1023SL035A	GEAR BEARING HOUSING
35B	P1023SL035B	HOUSING CAP
35C	PS06	PHLP HD SCR 10-24 X 3/8
35D	PLW03	LOCK WASHER #10
36	PSB26	CAP SCREW 3/8-16 X 1-1/2
37A	PLW04	LOCK WASHER 3/8
37B	PK03	KEY 1/4 X 1/4 X 45
38	P1023SL038	BEARING 6203-2RS
40	P1023RL138	THIN LOCK NUT 5/8-18 LH
41	P1023SL041	COLLAR
42	P1023SL042	ARBOR PULLEY
43	PSS10	SET SCREW 1/4-20 X 5/8
43A	PSS06	SET SCREW 1/4-20 X 3/4

REF PART #	DESCRIPTION	
44	PK02M	KEY 5 X 5 X 40L
45	P1023SL045	BLADE ARBOR
47	P1023SL047	ARBOR FLANGE
48	P1023SL048	ARBOR NUT
50	P1023SL050	MOTOR FRAME SUPPORT
51	P1023SL051	CLIP
52	P1023SL052	PIVOT PIN
53	PSB14	CAP SCREW 3/8-16 X 1"
54	P1023SL054	(3) V-BELTS M-25 3L250 MATCHED
55	P1023SL055	MOTOR PULLEY
56	P1023SL056	MOTOR 3HP, 220V, 1-PH
56	P1023SLWX056	MOTOR 5 HP, 220V, 1-PH
56	P1023SLWX3056	MOTOR 5 HP, 220V/440V, 3-PH
56A	P1023SL056A	MOTOR PLATE
56-1	P1023SL056-1	MOTOR FAN (3HP, 1-PH)
56-1	P1023SLWX056-1	MOTOR FAN (5HP, 1-PH)
56-1	P1023SLWX3056-1	MOTOR FAN (5HP, 3-PH)
56-2	P1023SL056-2	MOTOR FAN COVER
56-2	P1023SLWX056-2	MOTOR FAN COVER (5HP, 1-PH)
56-2	P1023SLWX3056-2	MOTOR FAN COVER (5HP, 3-PH)
56-3	P1023SL056-3	CAPACITOR COVER (3HP, 1-PH)
56-3	P1023SLWX056-3	CAPACITOR COVER (5HP, 1-PH)
56-5	PC600	START CAP 600MF 125V (3HP, 1-PH)
56-5	P1023SLWX056-5	START CAP 400MF 125V (5HP, 1-PH)
56-6	P1023SL056-6	WIRING BOX (3HP, 1-PH)
56-6	P1023SLWX056-6	WIRING BOX (5HP, 1-PH)
56-6	P1023SLWX3056-6	WIRING BOX (5HP, 3-PH)
56-7	P1023SLWX056-7	CAPACITOR COVER
56-8	P1023SLWX056-8	RUN CAP 50UF 350V (5HP, 1-PH)
61	PW07	FLAT WASHER 5/16
63A	P1023SL063A	REAR TRUNNION
63B	P1023SL063B	BUSHING
64	PRP07	ROLL PIN 5/16 X 1
65	PSB14	CAP SCREW 3/8-16 X 1"
66	PLW04	LOCK WASHER 3/8
68	P1023SL068	SHAFT
69	PLN05	LOCK NUT 3/4-16
70	P1023SL070	REAR TRUNNION BRACKET
89	PK02M	KEY 5 X 5 X 40MM
92	PW07	LOCK WASHER 5/16
94	P1023SL094	DUST DEFLECTOR
95	P1023SL095	SPECIAL SCREW 5/16-18 X 1-1/4
95A	PSS08	SET SCREW 5/16-18 X 1/2
95B	PN02	HEX NUT 5/16-18
99	PB32	HEX BOLT 5/16-18 X 5/8
85	PW02	FLAT WASHER 3/8
216	PAW08M	HEX WRENCH 8MM
217	P1023SL217	ARBOR WRENCH
220	PAW03M	HEX WRENCH 3MM
221	PAW04M	HEX WRENCH 4MM
222	P1023SL222	FLAT WRENCH 22MM



# G1023SL (All) Miter Gauge & Blade Guard

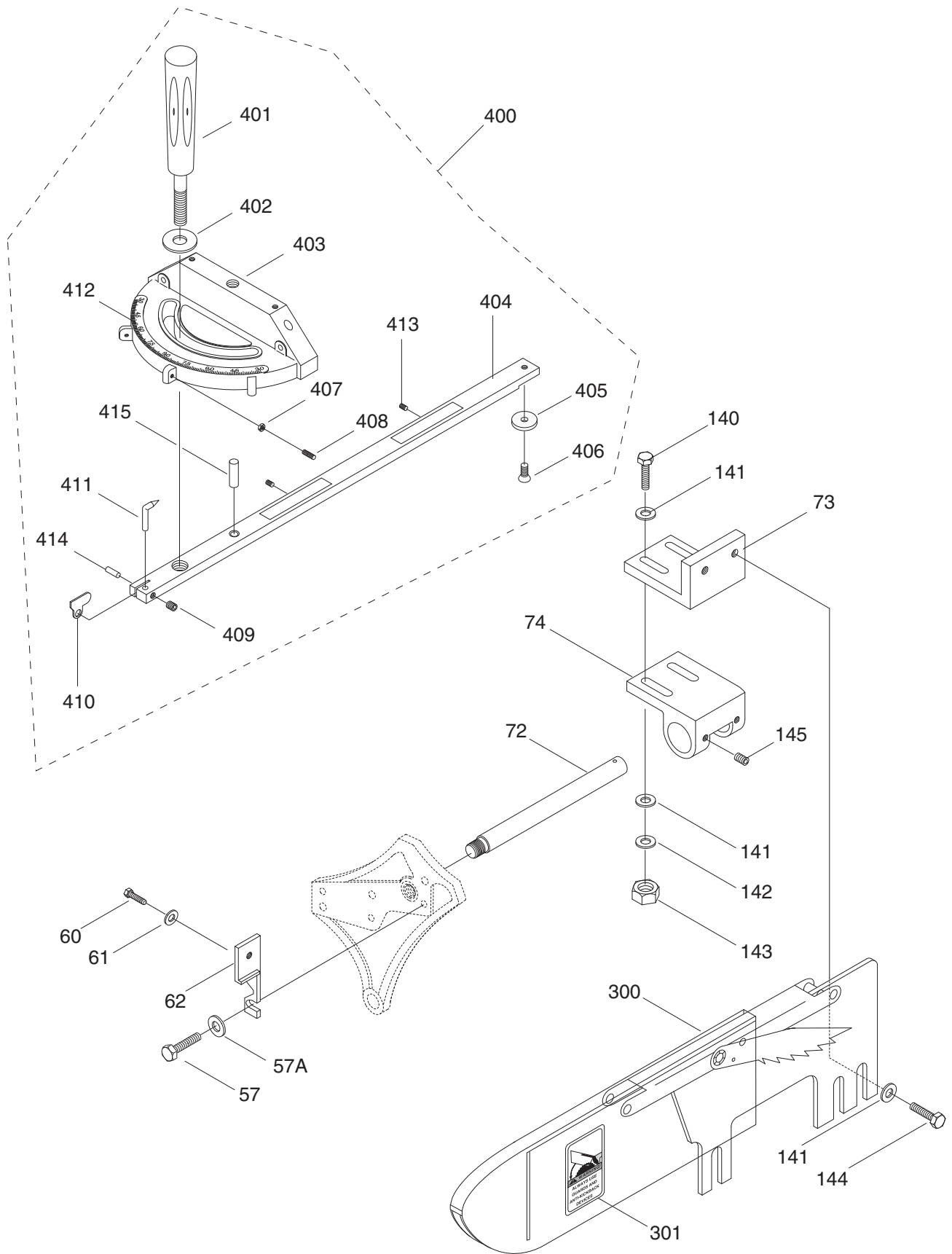

# G1023SL (All) Miter Gauge & Blade Guard

REF	PART #	DESCRIPTION
57	PB15	HEX BOLT 5/16-18 X 3/8
57A	PW07	FLAT WASHER 5/16
60	PB07	HEX BOLT 5/16-18 X 3/4
61	PW07	FLAT WASHER 5/16
62	P1023SL062	BRACKET
72	P1023SL072	SHAFT
73	P1023SL073	UPPER GUARD BRACKET
74	P1023SL074	LOWER GUARD BRACKET
140	PB11	HEX BOLT 5/16-18 X 1-1/2
141	PW07	FLAT WASHER 5/16
142	PLW01	LOCK WASHER 5/16
143	PN02	HEX NUT 5/16-18
144	PB03	HEX BOLT 5/16-18 X 1"
145	PSS02	SET SCREW 5/16-18 X 3/8
300	P1023SL300	BLADE GUARD ASSEMBLY
301	P1023SL301	USE GUARD LABEL

REF	PART #	DESCRIPTION
400	P1023400	COMPLETE MITER GAUGE
401	P1023401A	HANDLE 5/16-18 X 1-1/4
402	PW07	FLAT WASHER 5/16
403	P1023403	MITER GAUGE BODY
404	P1023404A	MITER BAR
405	P1023405	SPECIAL WASHER
406	PFH09	FLAT HD SCR 1/4-20 X 5/16
407	PN07	HEX NUT 10-24
408	PSS32	SET SCREW 10-24 X 3/4
409	PSS34	SET SCREW 10-24 X 1/2
410	P1023410	STOP
411	P1023411	POINTER
412	P1023412	SCALE
413	PSS31	SET SCREW 10-24 X 5/8
414	PRP50M	ROLL PIN 1.5 X 13
415	P1023SL415	MITER HINGE PIN

## WARNING

Safety labels warn about machine hazards and ways to prevent injury. The owner of this machine **MUST** maintain the original location and readability of the labels on the machine. If any label is removed or becomes unreadable, **REPLACE** that label before using the machine again. Contact Grizzly at (800) 523-4777 or [www.grizzly.com](http://www.grizzly.com) to order new labels.



# G1023SL (All) Fence

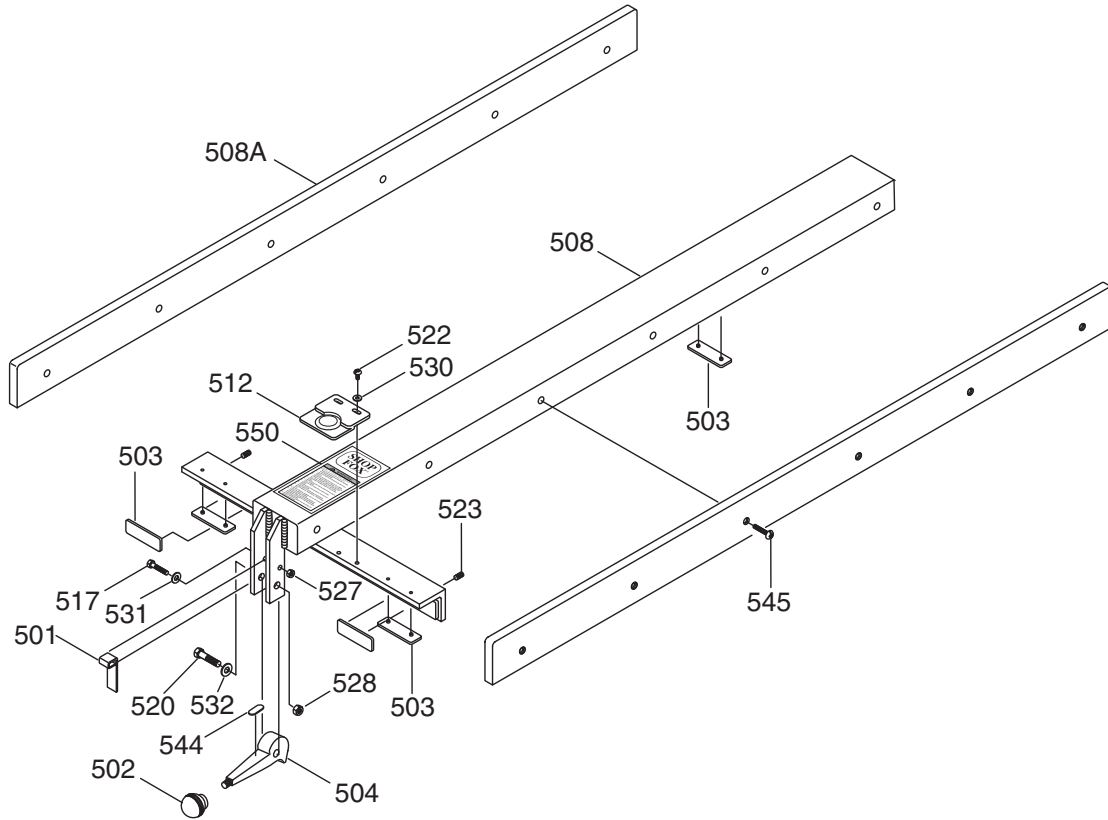

REF	PART #	DESCRIPTION
501	P1023SL501	FENCE LOCKING TAB
502	P1023SL502	KNOB
503	P1023SL503	BEARING PAD
504	P1023SL504	LOCKING LEVER
508	P1023SL508	FENCE BODY
508A	P1023SL508A	FENCE FACING
512	P1023SL512	MAGNIFIED CURSOR
517	PB88	HEX BOLT 1/4 - 20 X 1-3/4
520	PB25	HEX BOLT 3/8-16 X 1-3/4
522	PS06	PHLP HD SCR 10-24 X 3/8

REF	PART #	DESCRIPTION
523	PSS48	SET SCREW 3/8-16 X 5/16
527	PLN02	LOCK NUT 1/4-20
528	PLN01	LOCK NUT 3/8-16
530	PW03	FLAT WASHER #10
531	PW06	FLAT WASHER 1/4
532	PW02	FLAT WASHER 3/8
544	P1023SL544	MAGNET
545	PS43	PHLP HD SCR 10-24 x 1/2
550	P1023SL550	FENCE WARNING LABEL

## WARNING

Safety labels warn about machine hazards and ways to prevent injury. The owner of this machine **MUST** maintain the original location and readability of the labels on the machine. If any label is removed or becomes unreadable, **REPLACE** that label before using the machine again. Contact Grizzly at (800) 523-4777 or [www.grizzly.com](http://www.grizzly.com) to order new labels.



# G1023SL, W, WX, WX3 Fence Rails

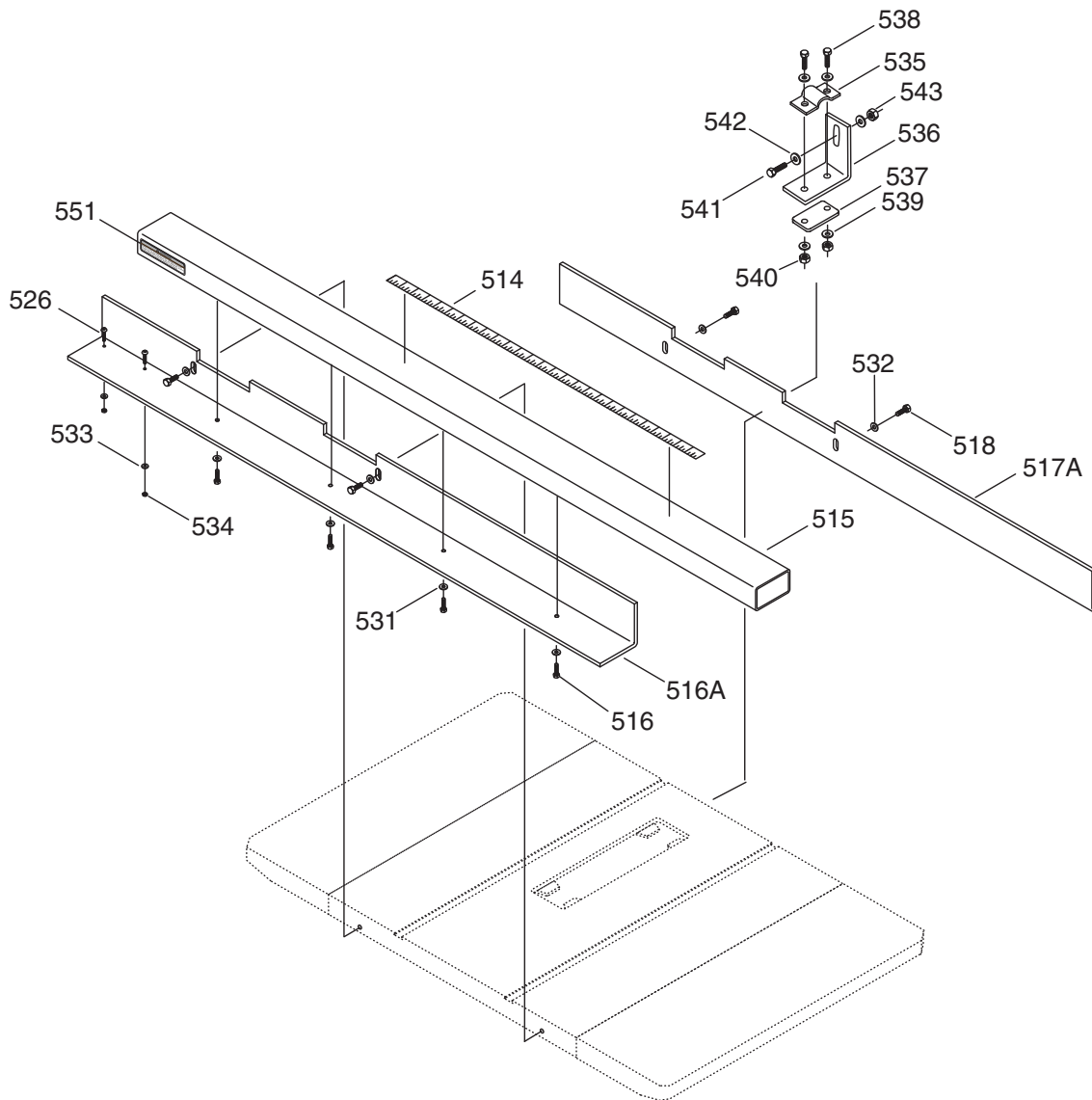

REF	PART #	DESCRIPTION
514	P1023SL514	SCALE
515	P1023SL515	FRONT RAIL TUBE
516	PB05	HEX BOLT 1/4-20 X 3/4
516A	P1023SL516A	FRONT RAIL SUPPORT
517A	P1023SL517A	REAR RAIL
518	PB18	HEX BOLT 3/8-16 X 1
526	PFH21	FLAT HD SCR 10-24 X 3/4
531	PW06	FLAT WASHER 1/4
532	PW02	FLAT WASHER 3/8
533	PW06	FLAT WASHER 1/4

REF	PART #	DESCRIPTION
536	P1023SL536	L-BRACKET
537	P1023SL537	LOCKING PLATE
538	PB26	HEX BOLT 1/4-20 X 1-1/2
539	PW06	FLAT WASHER 1/4
540	PN05	HEX NUT 1/4-20
541	PB07	HEX BOLT 5/16-18 X 3/4
542	PW07	FLAT WASHER 5/16
543	PN02	HEX NUT 5/16-18
551	P1023SL551	RAIL WARNING LABEL



# G1023SLX Fence Rails

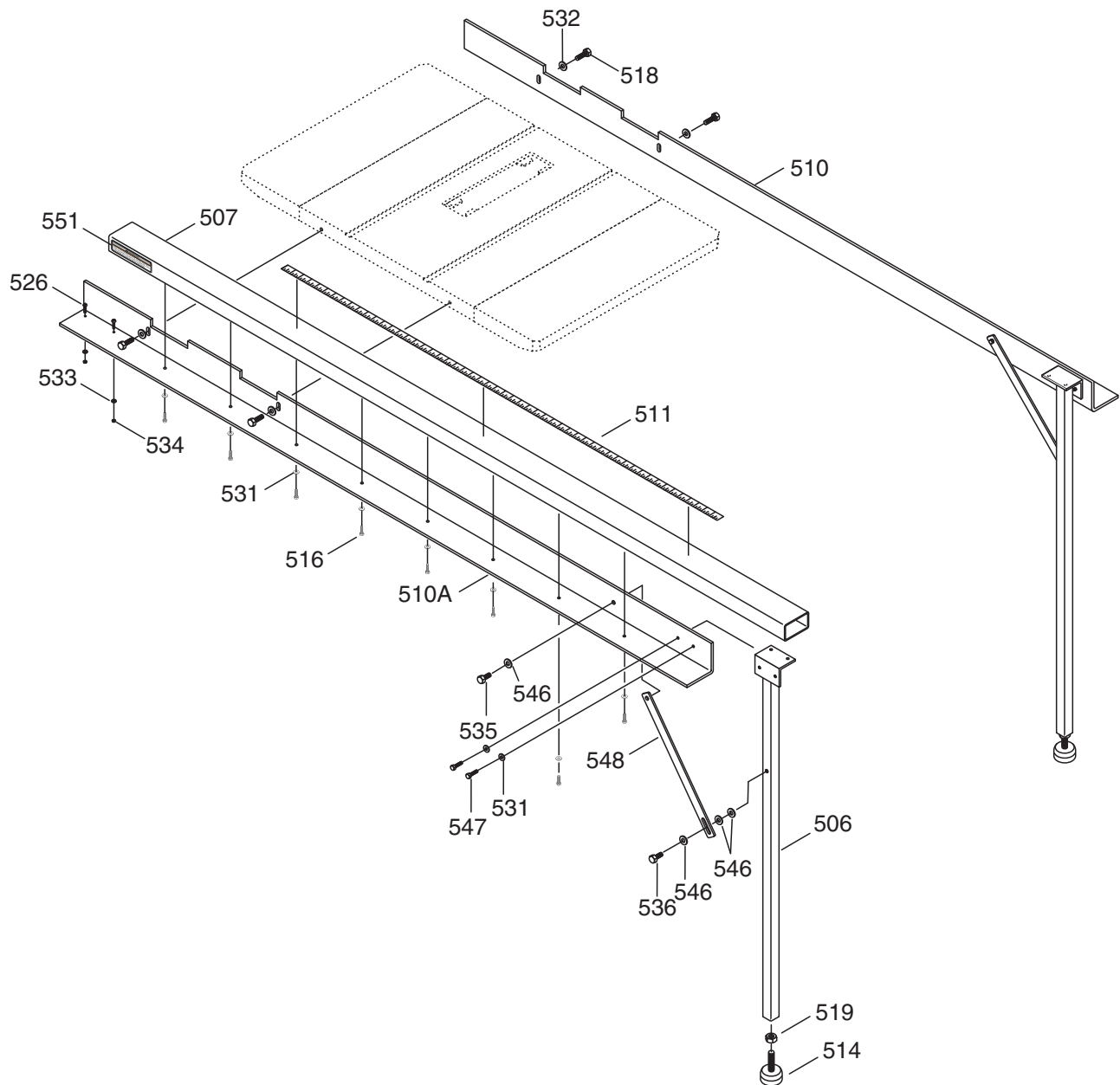

REF	PART #	DESCRIPTION
506	P1023SLX506	EXTENSION LEG
507	P1023SLX507	FRONT RAIL TUBE
510	P1023SLX510	REAR RAIL
510A	P1023SLX510A	FRONT RAIL SUPPORT
511	P1023SLX511	SCALE
514	P1023SLX514	ADJUSTABLE FOOT
516	PB05	HEX BOLT 1/4-20 X 3/4
518	PB18	HEX BOLT 3/8-16 X 1
519	PN34	HEX NUT 1/2-12
526	PFH21	FLAT HD SCR 1/4-20 X 3/4

REF	PART #	DESCRIPTION
531	PW06	FLAT WASHER 1/4
532	PW02	FLAT WASHER 3/8
533	PW06	FLAT WASHER 1/4
534	PN05	HEX NUT 1/4-20
535	PB65	HEX BOLT 3/8-16 X 5/8
536	PB21	HEX BOLT 3/8-16 X 3/4
546	PW02	FLAT WASHER 3/8
547	PB19	HEX BOLT 1/4-20 X 1/2
548	P1023SLX548	BRACE
551	P1023SL551	RAIL WARNING LABEL



# G1023SLW, X, X3 Router Table & Legs Parts

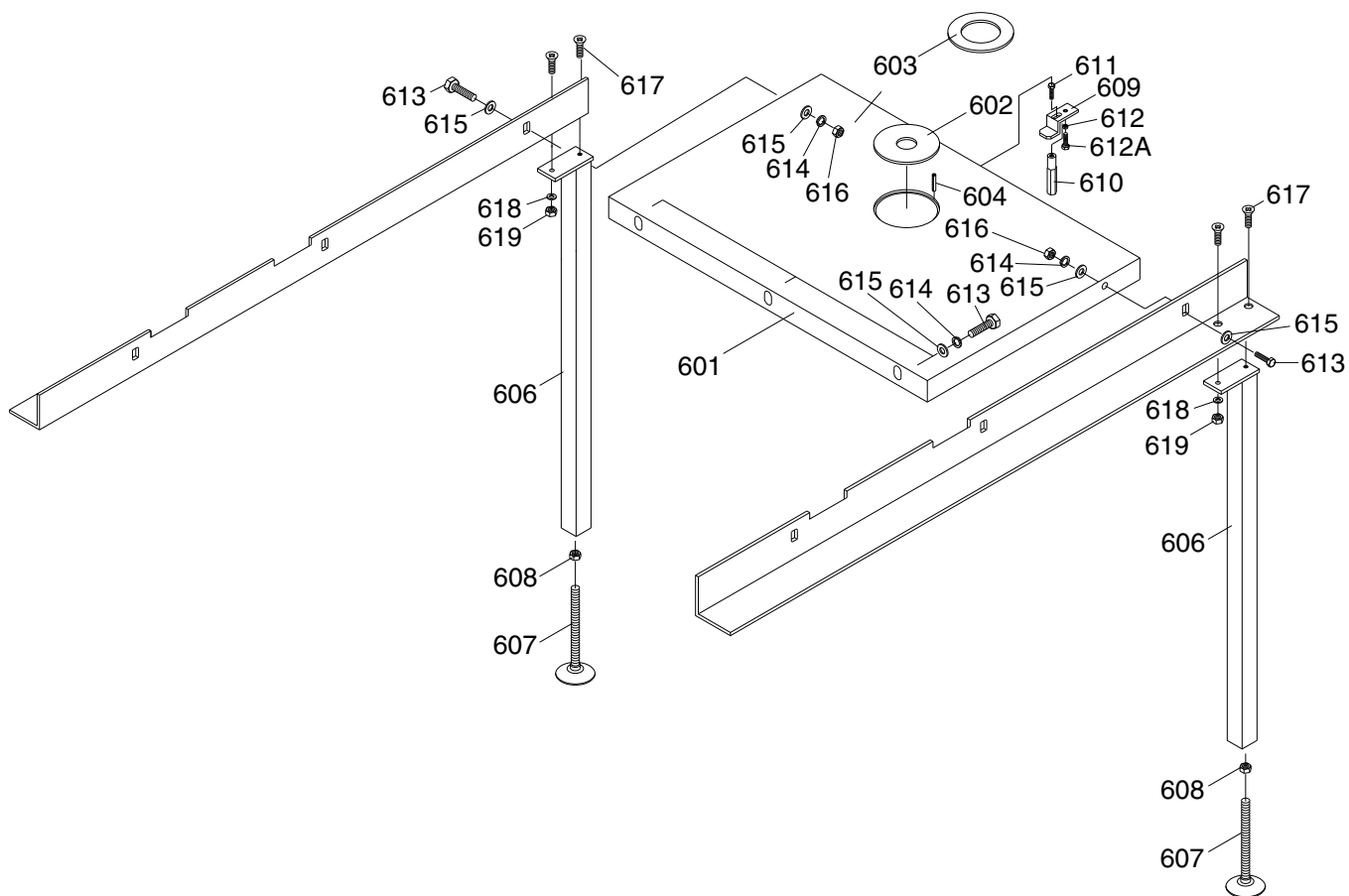

REF	PART #	DESCRIPTION
601	P1023SLW601	ROUTER TABLE EXT WING
602	P1023SLW602	TABLE INSERT 29MM
603	P1023SLW603	TABLE INSERT 60MM
604	P1023SLW604	ROLL PIN 3 X 9
606	P1023SLW606	EXTENSION LEG
607	P1023SLW607	ADJUSTABLE FOOT
608	PN06	HEX NUT 1/2-12
609	P1023SLW609	MOTOR CLAMP PIECE
610	P1023SLW610	STUD
611	PB10	HEX BOLT 1/4-20 X 2

REF	PART #	DESCRIPTION
612	PN05	HEX NUT 1/4-20
612A	PB31	HEX BOLT 1/4-20 X 1
613	PB24	HEX BOLT 3/8-16 X 1-1/4
614	PLW04	LOCK WASHER 3/8
615	PW02	FLAT WASHER 3/8
616	PN08	HEX NUT 3/8-16
617	PFH05	FLAT HD SCR 1/4-20 X 3/4
618	PW06	FLAT WASHER 1/4
619	PN05	HEX NUT 1/4-20



# WARRANTY AND RETURNS

---

Grizzly Industrial, Inc. warrants every product it sells for a period of **1 year** to the original purchaser from the date of purchase. This warranty does not apply to defects due directly or indirectly to misuse, abuse, negligence, accidents, repairs or alterations or lack of maintenance. This is Grizzly's sole written warranty and any and all warranties that may be implied by law, including any merchantability or fitness, for any particular purpose, are hereby limited to the duration of this written warranty. We do not warrant or represent that the merchandise complies with the provisions of any law or acts unless the manufacturer so warrants. In no event shall Grizzly's liability under this warranty exceed the purchase price paid for the product and any legal actions brought against Grizzly shall be tried in the State of Washington, County of Whatcom.

We shall in no event be liable for death, injuries to persons or property or for incidental, contingent, special, or consequential damages arising from the use of our products.

To take advantage of this warranty, contact us by mail or phone and give us all the details. We will then issue you a "Return Number," which must be clearly posted on the outside as well as the inside of the carton. We will not accept any item back without this number. Proof of purchase must accompany the merchandise.

The manufacturers reserve the right to change specifications at any time because they constantly strive to achieve better quality equipment. We make every effort to ensure that our products meet high quality and durability standards and we hope you never need to use this warranty.

Please feel free to write or call us if you have any questions about the machine or the manual.

Thank you again for your business and continued support. We hope to serve you again soon.





# WARRANTY CARD

Name \_\_\_\_\_  
 Street \_\_\_\_\_  
 City \_\_\_\_\_ State \_\_\_\_\_ Zip \_\_\_\_\_  
 Phone # \_\_\_\_\_ Email \_\_\_\_\_ Invoice # \_\_\_\_\_  
 Model # \_\_\_\_\_ Order # \_\_\_\_\_ Serial # \_\_\_\_\_

The following information is given on a voluntary basis. It will be used for marketing purposes to help us develop better products and services. **Of course, all information is strictly confidential.**

1. How did you learn about us?

Advertisement                       Friend                       Catalog  
 Card Deck                               Website                       Other:

2. Which of the following magazines do you subscribe to?

<input type="checkbox"/> Cabinet Maker	<input type="checkbox"/> Popular Mechanics	<input type="checkbox"/> Today's Homeowner
<input type="checkbox"/> Family Handyman	<input type="checkbox"/> Popular Science	<input type="checkbox"/> Wood
<input type="checkbox"/> Hand Loader	<input type="checkbox"/> Popular Woodworking	<input type="checkbox"/> Wooden Boat
<input type="checkbox"/> Handy	<input type="checkbox"/> Practical Homeowner	<input type="checkbox"/> Woodshop News
<input type="checkbox"/> Home Shop Machinist	<input type="checkbox"/> Precision Shooter	<input type="checkbox"/> Woodsmith
<input type="checkbox"/> Journal of Light Cont.	<input type="checkbox"/> Projects in Metal	<input type="checkbox"/> Woodwork
<input type="checkbox"/> Live Steam	<input type="checkbox"/> RC Modeler	<input type="checkbox"/> Woodworker West
<input type="checkbox"/> Model Airplane News	<input type="checkbox"/> Rifle	<input type="checkbox"/> Woodworker's Journal
<input type="checkbox"/> Modeltec	<input type="checkbox"/> Shop Notes	<input type="checkbox"/> Other:
<input type="checkbox"/> Old House Journal	<input type="checkbox"/> Shotgun News	

3. What is your annual household income?

\$20,000-\$29,000                       \$30,000-\$39,000                       \$40,000-\$49,000  
 \$50,000-\$59,000                       \$60,000-\$69,000                       \$70,000+

4. What is your age group?

20-29                                       30-39                                       40-49  
 50-59                                       60-69                                       70+

5. How long have you been a woodworker/metalworker?

0-2 Years                       2-8 Years                       8-20 Years                       20+ Years

6. How many of your machines or tools are Grizzly?

0-2                       3-5                       6-9                       10+

7. Do you think your machine represents a good value?                       Yes                       No

8. Would you recommend Grizzly Industrial to a friend?                       Yes                       No

9. Would you allow us to use your name as a reference for Grizzly customers in your area?  
**Note:** We never use names more than 3 times.                       Yes                       No

10. Comments: \_\_\_\_\_  
 \_\_\_\_\_  
 \_\_\_\_\_

CUT ALONG DOTTED LINE

FOLD ALONG DOTTED LINE

\_\_\_\_\_

\_\_\_\_\_

\_\_\_\_\_



Place  
Stamp  
Here



**GRIZZLY INDUSTRIAL, INC.**  
P.O. BOX 2069  
BELLINGHAM, WA 98227-2069



FOLD ALONG DOTTED LINE

Send a Grizzly Catalog to a friend:

Name \_\_\_\_\_

Street \_\_\_\_\_

City \_\_\_\_\_ State \_\_\_\_\_ Zip \_\_\_\_\_

TAPE ALONG EDGES--PLEASE DO NOT STAPLE



# *grizzly.com*

**TOOL WEBSITE**

Buy Direct and Save with Grizzly® – Trusted, Proven and a Great Value!

*Visit Our Website Today And Discover  
Why Grizzly® Is The Industry Leader!*

- SECURE ORDERING
- ORDERS SHIPPED WITHIN 24 HOURS
- E-MAIL RESPONSE WITHIN ONE HOUR

-OR-

Call Today For A **FREE**  
Full Color Catalog

**1-800-523-4777**

