

# *Grizzly* **Industrial, Inc.**®

## **40" PAN AND BOX BRAKE MODEL G0578 INSTRUCTION MANUAL**



COPYRIGHT © FEBRUARY 2005 BY GRIZZLY INDUSTRIAL, INC.  
**WARNING: NO PORTION OF THIS MANUAL MAY BE REPRODUCED IN ANY SHAPE  
OR FORM WITHOUT THE WRITTEN APPROVAL OF GRIZZLY INDUSTRIAL, INC.**  
#BL6901 PRINTED IN CHINA



# Table of Contents

- INTRODUCTION..... 2**
  - Foreword ..... 2
  - Contact Info ..... 2
  - Identification ..... 4
- SECTION 1: SAFETY ..... 5**
  - Safety Instructions for Machinery ..... 5
  - Additional Safety Instructions for Pan and Box Brakes ..... 7
- SECTION 2: SET UP ..... 8**
  - About this Section ..... 8
  - Unpacking ..... 8
  - Inventory..... 9
  - Hardware Recognition Chart..... 10
  - Clean Up ..... 11
  - Site Considerations ..... 12
  - Installing Base Extension Brackets..... 12
  - Mounting to Floor ..... 13
- SECTION 3: OPERATIONS ..... 15**
  - Operation Safety ..... 15
  - Capability..... 15
  - Positioning Operating Handle ..... 15
  - Adjusting Setback ..... 16
  - Using Foot Pedal..... 17
  - Adjusting Clamping Pressure..... 18
  - Aligning Fingers ..... 18
  - Spacing Fingers ..... 19
  - Basic Bending ..... 20
  - Setting Adjustable Stop..... 20
  - Bending Allowance..... 21
- SECTION 4: MAINTENANCE ..... 22**
  - Lubrication..... 22
  - G0578 Parts Breakdown ..... 23
  - G0578 Parts List ..... 24
- WARRANTY AND RETURNS ..... 25**

# INTRODUCTION

---

---

## Foreword

---

---

We are proud to offer the Model G0578 40" Pan and Box Brake. This pan and box brake is part of a growing Grizzly family of fine metalworking machinery. When used according to the guidelines set forth in this manual, you can expect years of trouble-free, enjoyable operation and proof of Grizzly's commitment to customer satisfaction.

We are pleased to provide this manual with the Model G0578 Pan and Box Brake. It was written to guide you through assembly, review safety considerations, and cover general operating procedures. It represents our effort to produce the best documentation possible.

The specifications, drawings, and photographs illustrated in this manual represent the Model G0578 Pan and Box Brake as supplied when the manual was prepared. However, owing to Grizzly's policy of continuous improvement, changes may be made at any time with no obligation on the part of Grizzly. For your convenience, we always keep current Grizzly manuals available on our website at [www.grizzly.com](http://www.grizzly.com). Any updates to your machine will be reflected in these manuals as soon as they are complete. Visit our site often to check for the latest updates to this manual!



## Contact Info

---

---

If you have any comments regarding this manual, please write to us at the address below:

Grizzly Industrial, Inc.  
c/o Technical Documentation  
P.O. Box 2069  
Bellingham, WA 98227-2069

We stand behind our machines. If you have any service questions or parts requests, please call or write us at the location listed below.

Grizzly Industrial, Inc.  
1203 Lycoming Mall Circle  
Muncy, PA 17756  
Phone: (570) 546-9663  
Fax: (800) 438-5901  
E-Mail: [techsupport@grizzly.com](mailto:techsupport@grizzly.com)  
Web Site: <http://www.grizzly.com>





# MACHINE DATA SHEET

Customer Service #: (570) 546-9663 • To Order Call: (800) 523-4777 • Fax #: (800) 438-5901

## MODEL G0578 40" PAN & BOX BRAKE

**Design Type**..... Pan & Box

**Overall Dimensions:**

Height.....45"  
 Finger Sizes..... 1", 1½", 1¾", 1⅝, 1½, 1¾, 2", 3", 4", 5", 8", 10"  
 Shipping Weight..... 627 lbs.  
 Footprint..... 46½" x 32½"  
 Crate Size .....25" L x 57⅝" W x 48⅝" H

**Capacities:**

Brake Range.....0° - 135°  
 Maximum Width.....40"  
 Maximum Height of Pan/Box Sides.....2½"  
 Mild Steel ..... 12 gauge  
 Aluminum ..... 6 gauge  
 Soft Brass ..... 10 gauge  
 Annealed Phosphor Bronze..... 11 gauge  
 Soft Copper..... 10 gauge  
 Hard Copper ..... 11 gauge

**Construction:**

Fingers.....Precision Ground Steel, Hardened Edge  
 Base..... Steel  
 Bending Leaf..... Steel  
 Clamping Leaf..... Steel

# Identification

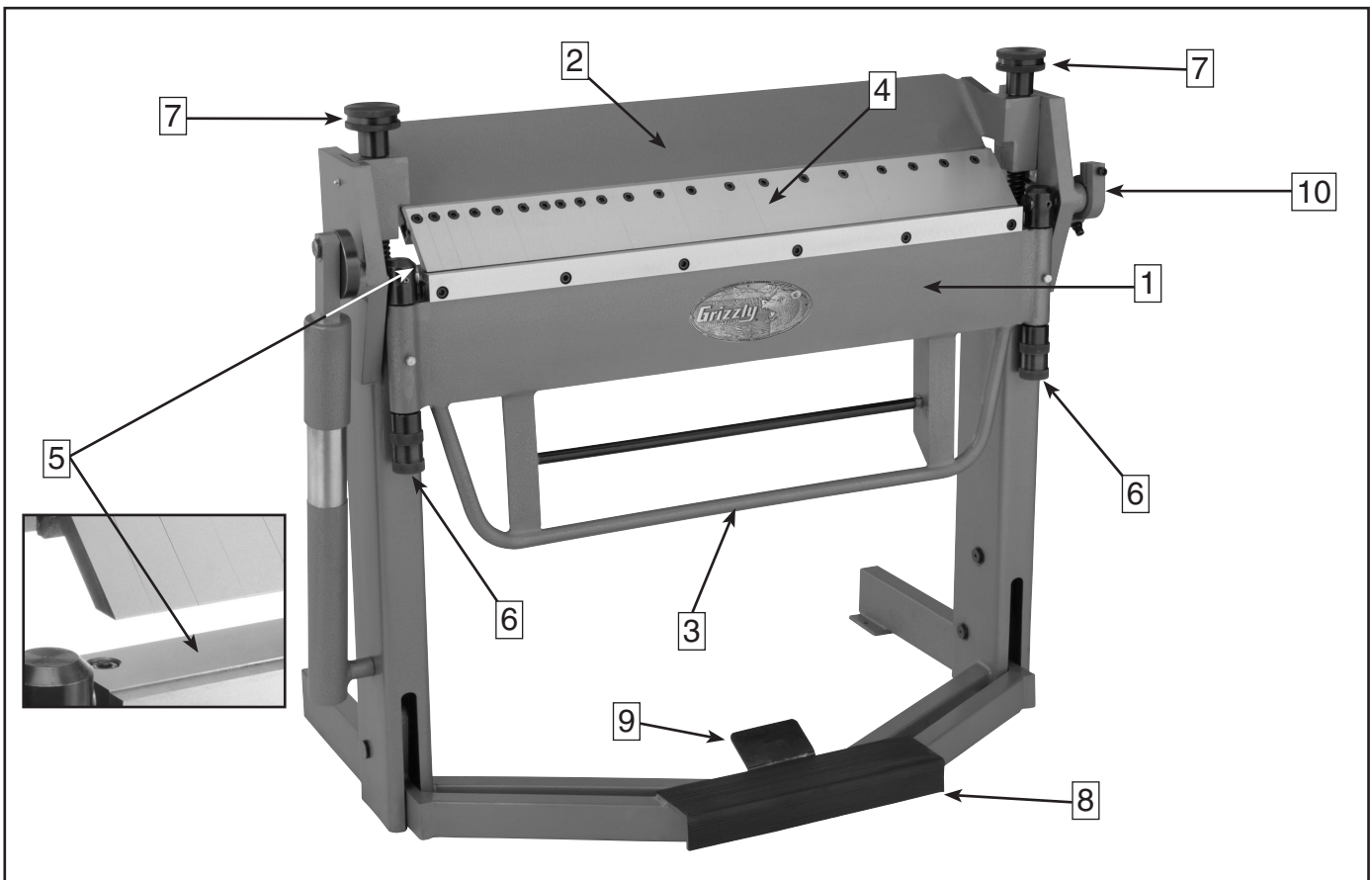

**Figure 1.** Common Pan and Box Brake components.

1. **Bending Leaf**—Swivels up to bend the workpiece.
2. **Clamping Leaf**—Holds the fingers. Squeezes the workpiece against the clamping block.
3. **Operating Handle**—Used to raise and lower the bending leaf.
4. **Finger Blocks**—Adjustable dies that the workpiece is bent against.
5. **Clamping Block**—Fixed block (or lower jaw) that the clamping leaf presses against.
6. **Setback Knobs**—Adjusts to the gauge of the workpiece and desired bend radius.
7. **Clamping Pressure Adjusting Nuts**—Adjusts pressure on the workpiece, allowing for different gauges.
8. **Foot Pedal**—Raises and lowers fingers onto clamping block.
9. **Foot Pedal Lock**—Locks foot pedal.
10. **Stop Collar**—Used to lock bending angle.

# SECTION 1: SAFETY

## **WARNING**

### **For Your Own Safety, Read Instruction Manual Before Operating this Machine**

The purpose of safety symbols is to attract your attention to possible hazardous conditions. This manual uses a series of symbols and signal words which are intended to convey the level of importance of the safety messages. The progression of symbols is described below. Remember that safety messages by themselves do not eliminate danger and are not a substitute for proper accident prevention measures.

 **DANGER** Indicates an imminently hazardous situation which, if not avoided, **WILL** result in death or serious injury.

 **WARNING** Indicates a potentially hazardous situation which, if not avoided, **COULD** result in death or serious injury.

 **CAUTION** Indicates a potentially hazardous situation which, if not avoided, **MAY** result in minor or moderate injury. It may also be used to alert against unsafe practices.

**NOTICE** This symbol is used to alert the user to useful information about proper operation of the machine.

## **WARNING**

### **Safety Instructions for Machinery**

- 1. READ THROUGH THE ENTIRE MANUAL BEFORE STARTING MACHINERY.** Machinery presents serious injury hazards to untrained users.
- 2. ALWAYS USE ANSI APPROVED SAFETY GLASSES WHEN OPERATING MACHINERY.** Everyday eyeglasses only have impact resistant lenses, they are NOT safety glasses.
- 3. ALWAYS WEAR AN ANSI APPROVED RESPIRATOR WHEN OPERATING MACHINERY THAT PRODUCES DUST.** Wood dust is a carcinogen and can cause cancer and severe respiratory illnesses.
- 4. ALWAYS USE HEARING PROTECTION WHEN OPERATING MACHINERY.** Machinery noise can cause permanent hearing damage.
- 5. WEAR PROPER APPAREL. DO NOT** wear loose clothing, gloves, neckties, rings, or jewelry which may get caught in moving parts. Wear protective hair covering to contain long hair and wear non-slip footwear.
- 6. NEVER OPERATE MACHINERY WHEN TIRED, OR UNDER THE INFLUENCE OF DRUGS OR ALCOHOL.** Be mentally alert at all times when running machinery.

# WARNING

## Safety Instructions for Machinery

7. **ONLY ALLOW TRAINED AND PROPERLY SUPERVISED PERSONNEL TO OPERATE MACHINERY.** Make sure operation instructions are safe and clearly understood.
8. **KEEP CHILDREN AND VISITORS AWAY.** Keep all children and visitors a safe distance from the work area.
9. **MAKE WORKSHOP CHILD PROOF.** Use padlocks, master switches, and remove start switch keys.
10. **NEVER LEAVE WHEN MACHINE IS RUNNING.** Turn power *OFF* and allow all moving parts to come to a complete stop before leaving machine unattended.
11. **DO NOT USE IN DANGEROUS ENVIRONMENTS.** DO NOT use machinery in damp, wet locations, or where any flammable or noxious fumes may exist.
12. **KEEP WORK AREA CLEAN AND WELL LIT.** Clutter and dark shadows may cause accidents.
13. **USE A GROUNDED EXTENSION CORD RATED FOR THE MACHINE AMPERAGE.** Undersized cords overheat and lose power. Replace extension cords if they become damaged. DO NOT use extension cords for 220V machinery.
14. **ALWAYS DISCONNECT FROM POWER SOURCE BEFORE SERVICING MACHINERY.** Make sure switch is in OFF position before reconnecting.
15. **MAINTAIN MACHINERY WITH CARE.** Keep blades sharp and clean for best and safest performance. Follow instructions for lubricating and changing accessories.
16. **MAKE SURE GUARDS ARE IN PLACE AND WORK CORRECTLY BEFORE USING MACHINERY.**
17. **REMOVE ADJUSTING KEYS AND WRENCHES.** Make a habit of checking for keys and adjusting wrenches before turning machinery *ON*.
18. **CHECK FOR DAMAGED PARTS BEFORE USING MACHINERY.** Check for binding and alignment of parts, broken parts, part mounting, loose bolts, and any other conditions that may affect machine operation. Repair or replace damaged parts.
19. **USE RECOMMENDED ACCESSORIES.** Refer to the instruction manual for recommended accessories. The use of improper accessories may cause risk of injury.
20. **DO NOT FORCE MACHINERY.** Work at the speed for which the machine or accessory was designed.
21. **SECURE WORKPIECE.** Use clamps or a vise to hold the workpiece when practical. A secured workpiece protects your hands and frees both hands to operate the machine.
22. **DO NOT OVERREACH.** Keep proper footing and balance at all times.
23. **MANY MACHINES WILL EJECT THE WORKPIECE TOWARD THE OPERATOR.** Know and avoid conditions that cause the workpiece to "kickback."
24. **ALWAYS LOCK MOBILE BASES BEFORE OPERATING MACHINERY.**

## **WARNING**

# Additional Safety Instructions for Pan and Box Brakes

- 1. OVERLOADING PAN AND BOX BRAKE.** Overloading this tool can cause injury from flying parts. Do not exceed the capacities specified on **Page 3**.
- 2. USING TORCHES.** Heating metal with a torch while the metal is in the pan and box brake will weaken the fingers.
- 3. METAL EDGES.** Always chamfer and deburr sharp sheet metal edges before bending in the pan and box brake. Sharp edges on sheet metal can cut your fingers to the bone.
- 4. PINCHING.** Lower the fingers when not in use, to prevent pinching hazard.
- 5. GLOVES AND GLASSES.** Always wear leather gloves and approved safety glasses when using this tool.
- 6. EXPERIENCING DIFFICULTIES.** If at any time you are experiencing difficulties performing the intended operation, STOP using the tool and contact our Technical Support at (570) 546-9663, or ask a qualified expert how the operation should be performed.
- 7. TOOLS IN POOR CONDITION.** Inspect the pan and box brake for any cracked linkage, levers, or loose fasteners. Correct any problems before use.

## **WARNING**

Like all machines there is danger associated with the Model G0578. Accidents are frequently caused by lack of familiarity or failure to pay attention. Use this machine with respect and caution to lessen the possibility of operator injury. If normal safety precautions are overlooked or ignored, serious personal injury may occur.

## **CAUTION**

No list of safety guidelines can be complete. Every shop environment is different. Always consider safety first, as it applies to your individual working conditions. Use this and other machinery with caution and respect. Failure to do so could result in serious personal injury, damage to equipment, or poor work results.

# SECTION 2: SET UP

## About this Section

The purpose of this section is to guide you through the required steps to get your equipment out of its packaging and into operating condition.

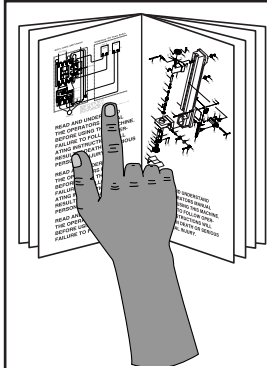

**!WARNING**  
This equipment presents serious injury hazards to untrained users. Read through this entire manual to become familiar with the operating procedures before using this equipment!

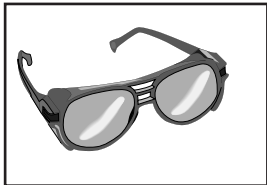

**!WARNING**  
Wear safety glasses during the entire setup process!



## Unpacking

The Model G0578 40" Pan and Box Brake was carefully packed when it left our warehouse. If you discover the equipment is damaged after you have signed for delivery, *please immediately call Customer Service at (570) 546-9663 for advice.*

Save the containers and all packing materials for possible inspection by the carrier or its agent. *Otherwise, filing a freight claim can be difficult.*

When you are completely satisfied with the condition of your shipment, you should inventory the parts.

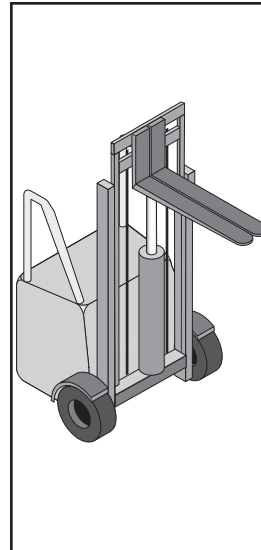

## **!WARNING**

The Model G0578 is a heavy machine that weighs approximately 627 lbs. Serious personal injury may occur if safe moving methods are not followed. To be safe, you will need assistance and power equipment when moving the shipping crate and removing the equipment from the crate.

### Lifting:

- If you are unsure of how to lift this equipment safely, consult a qualified professional.
- When lifting the pan and box brake, make sure the weight is supported evenly with two or more lifting devices.
- Make sure the body of the brake is bearing the load (**Figure 2**).

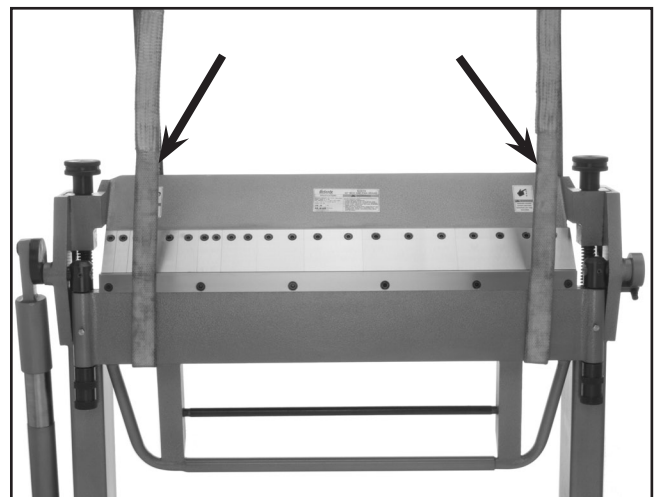

**Figure 2.** Pan and box brake supported evenly by two lifting straps.



# Inventory

---

After all the parts have been removed from the shipping crate, you should have the following items:

Box 1 (Figures 3 & 4):	QTY
A. Pan and Box Brake Main Body .....	1
B. Base Extension Brackets .....	2
C. Cap Screws M10-1.5 x 30 .....	4
D. Hex Wrench 8MM.....	1



**Figure 3.** Pan and box brake removed from shipping crate.

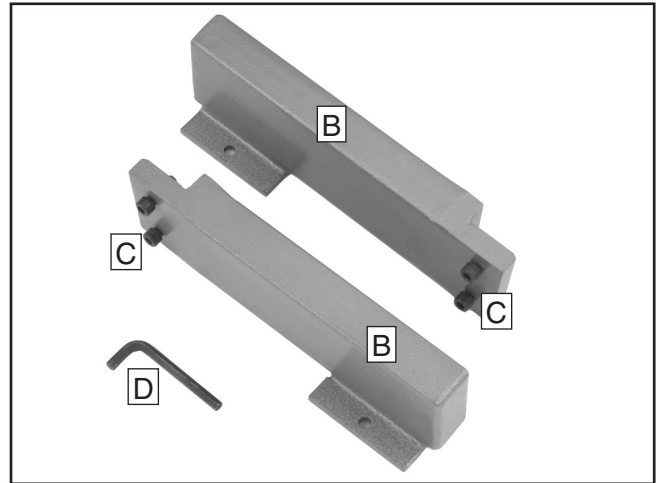

**Figure 4.** Base extension brackets, cap screws, and 8mm hex wrench.



# Hardware Recognition Chart

USE THIS CHART TO MATCH UP  
HARDWARE DURING THE ASSEMBLY  
PROCESS!

MEASURE BOLT DIAMETER BY PLACING INSIDE CIRCLE

- #10
- 1/4"
- 5/16"
- 3/8"
- 7/16"
- 1/2"

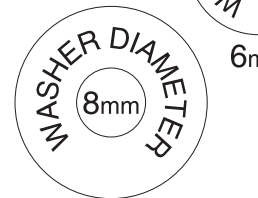
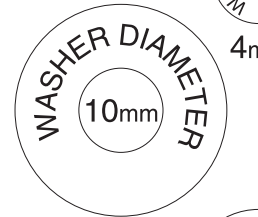
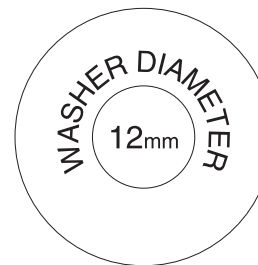
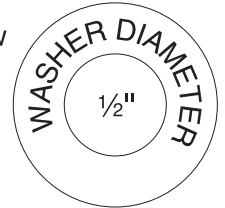
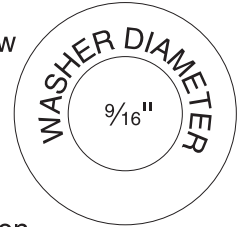
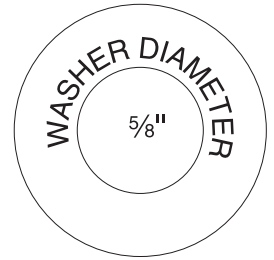
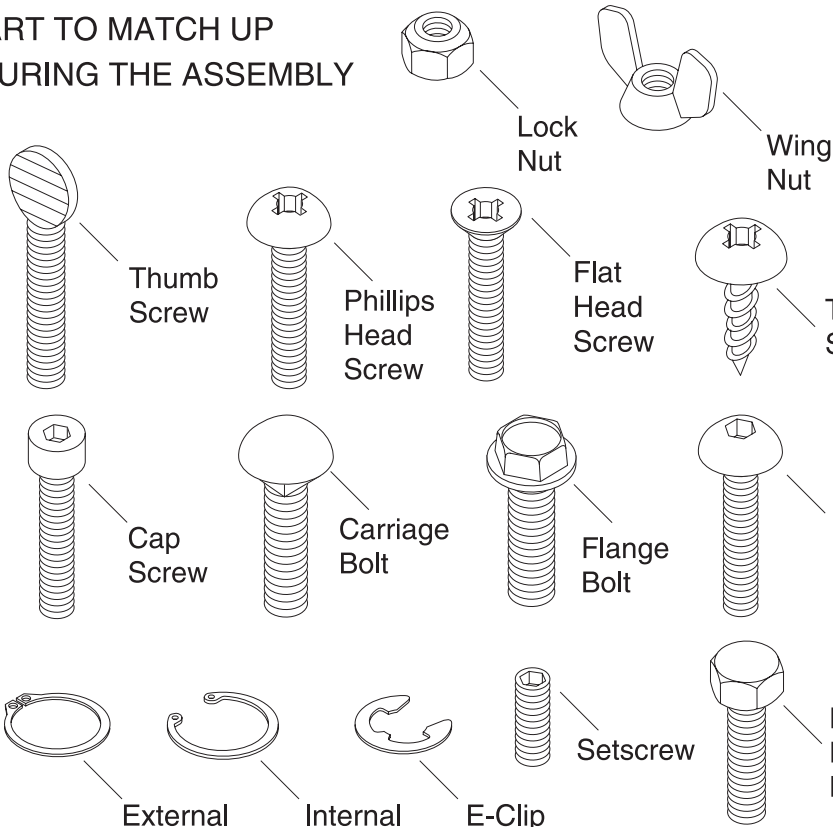

#10

WASHERS ARE MEASURED BY THE INSIDE DIAMETER

- 4mm
- 6mm
- 8mm
- 10mm
- 12mm
- 16mm

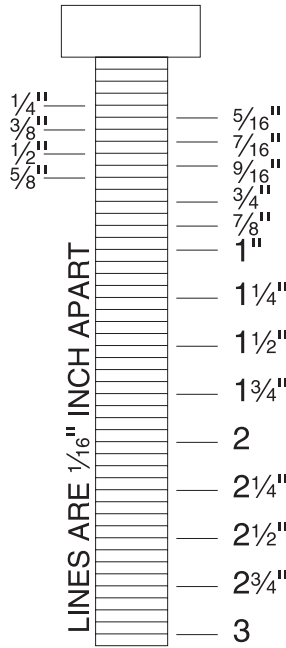
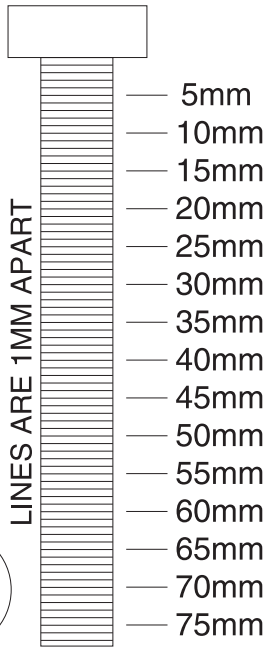

# Clean Up

The unpainted surfaces are coated with a waxy oil to protect them from corrosion during shipment. Remove this protective coating with a solvent cleaner or citrus-based degreaser such as Grizzly's G7895 Degreaser or with liberal amounts of WD-40®.

Remove and thoroughly clean each finger block assembly. To remove single fingers, raise the clamping leaf with the foot pedal (see *Using Foot Pedal*, **Page 17**) to make sure there is no pressure on the fingers. Unscrew the cap screw(s) as shown in **Figure 5** with an 8mm hex wrench, remove the finger, and leave its respective T-nut(s) in the front guide.

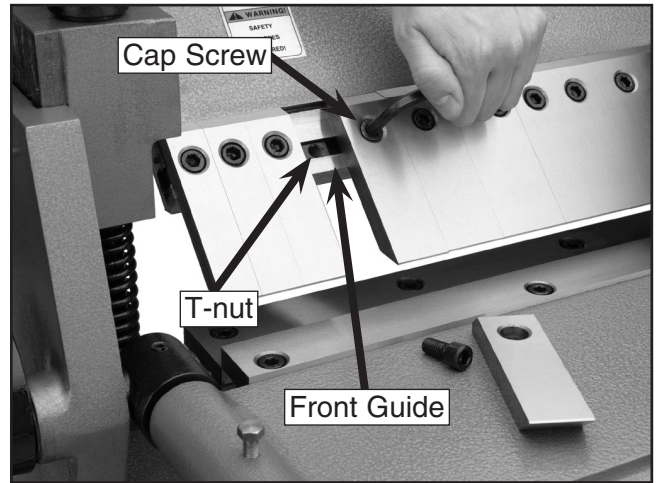

**Figure 5.** Removing finger blocks.

After the finger block assemblies have been cleaned, coat them liberally with a metal protectant and reinstall.

Place the fingers over the clamping leaf front guide, align the cap screw holes and the T-nut holes, insert the cap screws into the T-nuts, and fasten them loosely. *Follow the instructions on Page 18 to re-align the fingers before operating your brake!*

For metal protectants, we recommend using G96® GUN TREATMENT (Model H3788) or BOESHIELD® T-9 (Model G2871). *Check with the current Grizzly catalog for pricing and a variety of other quality metal protectants.*

	<p><b>⚠ WARNING</b> Do not clean with gasoline or other petroleum-based solvents. They have low flash points which make them extremely flammable. A risk of explosion and burning exists if these products are used.</p>
--	--

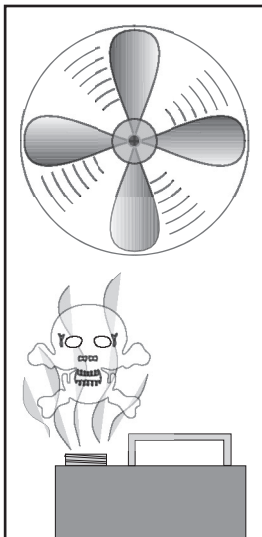
	<p><b>⚠ CAUTION</b> Many of the solvents commonly used to clean machinery can be toxic when inhaled or ingested. Always work in well-ventilated areas far from potential ignition sources when dealing with solvents. Use care when disposing of waste rags and towels to be sure they do not create fire or environmental hazards.</p>
---	---



# Site Considerations

---

## Floor Load

Your Model G0578 weighs approximately 627 lbs. and has a footprint of 46½" x 32½". Most concrete floors should be sufficient to carry the weight. *BEFORE* moving the brake onto a wood floor, inspect it carefully to determine that it will be sufficient to carry the load of the machine, the lifting device and its operators. If you question the strength of your floor, you should consider having it inspected for possible reinforcement.

## Working Clearances

Working clearances can be thought of as the distances between machines and obstacles that allow safe operation of every machine without limitation. Consider existing and anticipated machine needs, size of material to be processed through each machine, and space for auxiliary stands or work tables. Also consider the relative position of each machine to one another for efficient material handling.

## Lighting

Lighting should be bright enough to eliminate shadows and prevent eye strain.

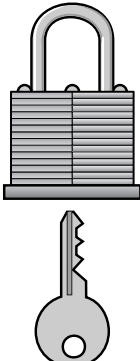
	<p><b>! CAUTION</b>  <b>Children and inexperienced users can be easily injured by this equipment. Ensure that your workplace is inaccessible to children and inexperienced users by closing and locking all entrances when you are away.</b></p>
---	--



# Installing Base Extension Brackets

---

<b>Components and Hardware Needed:</b>	<b>QTY</b>
Pan and Box Brake Main Body .....	1
Base Extension Brackets .....	2
Cap Screws M10-1.5 x 30.....	4

<b>Tools Needed:</b>	
8MM Hex Wrench.....	1

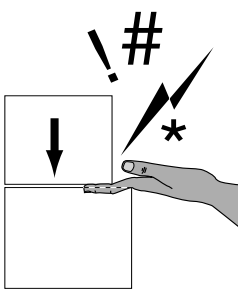
	<p><b>! CAUTION</b>  <b>Some components for this equipment are heavy and awkward to handle. Assembling them without proper equipment may increase the likelihood of injury.</b></p>
--	---

Install the two base extension brackets to maximize the stability of the Model G0578.

### To mount the main body to the base extension brackets:

1. Remove the brackets from the wrapping that secures them to the main body.

*Continued on next page* →

2. Line up the bracket holes (**Figure 6**) with the holes on the bottom of the main body legs and secure with the four cap screws, as shown in **Figure 7**.

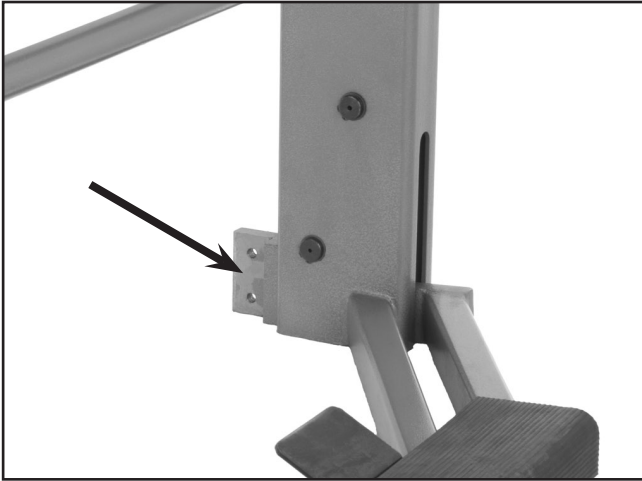

**Figure 6.** Location on main body to install base extension brackets.

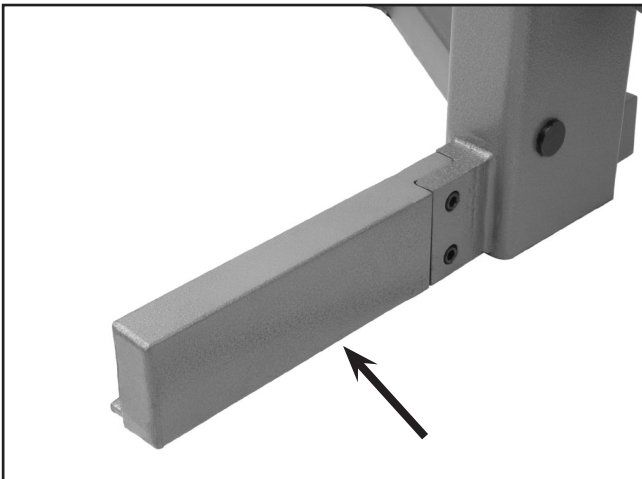

**Figure 7.** Base extension bracket installed onto main body (one of two brackets shown).



## Mounting to Floor

Although not required, we strongly recommend that you mount your new pan and box brake to a floor. Use the two holes in the base extension brackets and the two holes under the foot pedal lock, shown in **Figure 8**, as a guide for drilling.



**Figure 8.** Floor mounting holes.

Because this is an optional step and floor materials vary, floor mounting hardware is not included. To ensure accurate operation results, make sure your mounting location is as level as possible and that you provide adequate work room all around the pan and box brake.

*Continued on next page* →

## Bolting to Concrete Floors

Lag shield anchors with lag bolts (**Figure 9**) and anchor studs (**Figure 10**) are two popular methods for anchoring an object to a concrete floor. We suggest you research the many options and methods for mounting your pan and box brake and choose the best that fits your specific application.

*Note—Anchor studs, as shown in **Figure 10**, are stronger and more permanent alternatives to lag shield anchors; however, they will stick out of the floor, which may cause difficulties if you decide to move your pan and box brake at a later point.*

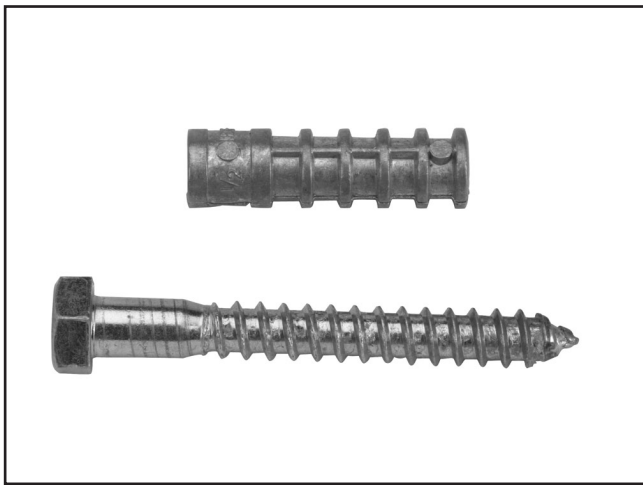

**Figure 9.** Typical lag shield anchor and lag bolt.

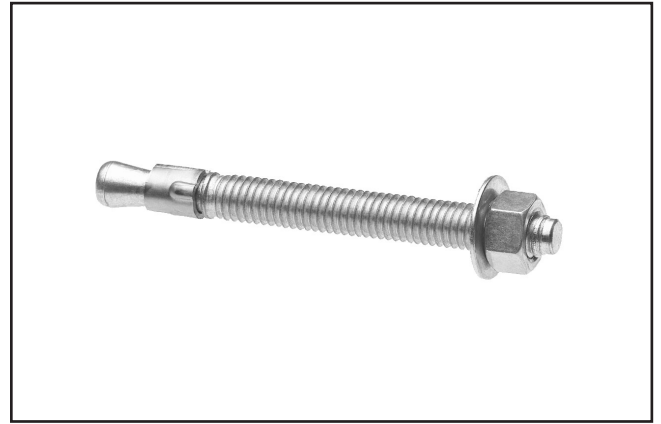

**Figure 10.** A typical anchor stud.



# SECTION 3: OPERATIONS

## Operation Safety

If you have never used this type of equipment before, WE STRONGLY RECOMMEND that you read books, trade magazines, or get formal training before beginning any projects.

**Your safety is important! Please follow the warnings below:**

	<b>! WARNING</b> Wear safety glasses during all operations!
---	--

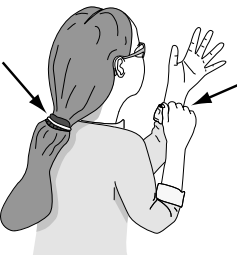
	<b>! WARNING</b> Loose hair and clothing could get caught in equipment and cause serious personal injury. Keep loose clothing rolled up and long hair tied up and away from moving equipment.
--	--

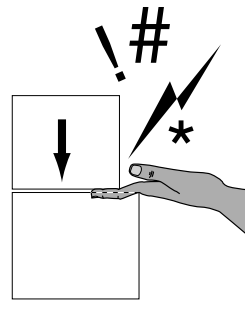
	<b>! WARNING</b> Watch for pinch points on this equipment. This equipment has many moving parts which may cause serious injury to yourself or others around the equipment.
---	---



## Capability

This pan and box brake is designed to fold boxes, pans, or trays from one piece of sheet metal.

A number of fingers of different widths on the clamping leaf can be put together in a variety of combinations to make bends of varying widths. This also permits the sides to be formed between the opposite sides that have been previously bent.



## Positioning Operating Handle

<b>Tools Needed:</b>	<b>QTY</b>
8MM Hex Wrench.....	1

The operating handle is folded down and locked with an 8mm hex wrench to secure it during shipping.

*Continued on next page* →

Loosen the cap screw shown in **Figure 11** so the bending leaf can be moved up and down for normal operation.

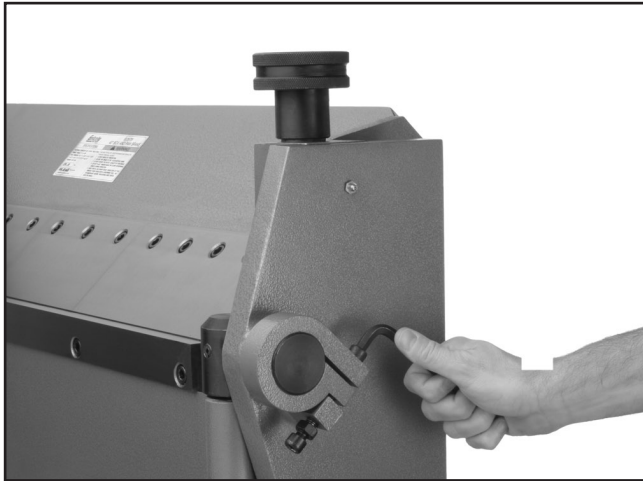

**Figure 11.** Loosening cap screw to allow bending leaf movement.



## Adjusting Setback

### **NOTICE**

**You must include the thickness of folded edges or joints when determining the proper setback, or the brake may be damaged.**

Before you begin any bending operation, please consider the differences of sheet metal gauges when trying to achieve either sharp or rounded edges, and allow for the differences by adjusting the setback.

The setback is the distance from the forward edge of the fingers to the edge of the bending leaf, as shown in **Figure 12**. The setback distance is determined by the gauge of the workpiece and the desired radius of the bend.

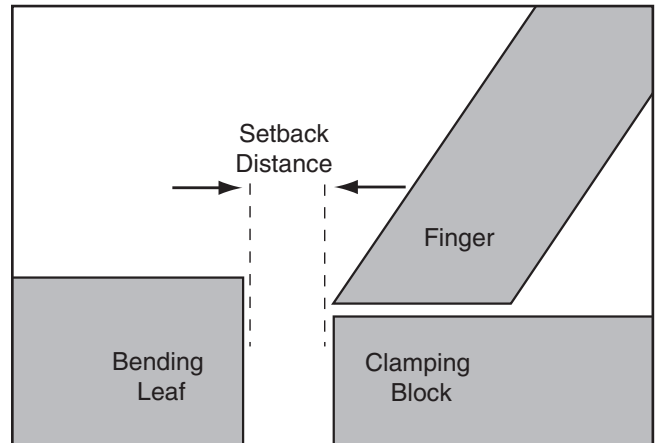
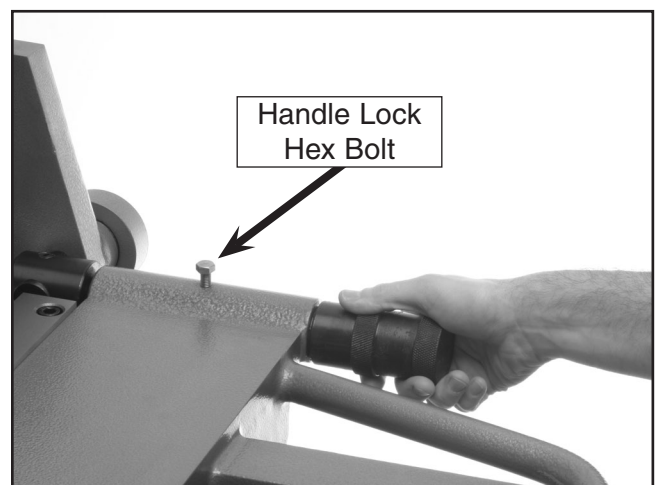

**Figure 12.** Setback distance.

Normally, setback is adjusted at least  $1\frac{1}{2}$ –2 times the thickness of the workpiece. (Thicker or tempered workpieces will need a larger setback. Refer to material gauge capacities on the machine data sheet on **Page 3**.)

#### **To adjust the setback:**

1. Evenly rotate both setback knobs clockwise, as shown in **Figure 13**, to move the front edge of the bending leaf toward the clamping block and the fingers.



**Figure 13.** Rotating setback knobs.

2. To move the bending leaf away from the fingers, evenly rotate setback knobs counter-clockwise several turns.
3. Firmly grasp the operating handle and pull the bending leaf toward you until it rests against the setback knobs.

If the setback distance is too much, repeat **Step 1**. Continue with the above adjustments until you obtain the proper setback distance.

*Note—When performing these adjustments, make sure the bending leaf is parallel with the clamping block, or your bend will be distorted.*

4. Lock the handle in place with hex bolts (**Figure 13**) on the bending leaf.



---

## Using Foot Pedal

---

The foot pedal is used to lower the clamping leaf fingers over the clamping block and place pressure on the workpiece. The pedal can be locked and unlocked. The foot pedal is locked during shipping.

### To engage the foot pedal:

1. Apply steady downward pressure on the foot pedal; as you do, the fingers lower correspondingly. The foot pedal lock should engage when the pedal is fully depressed, as shown in **Figure 14**.

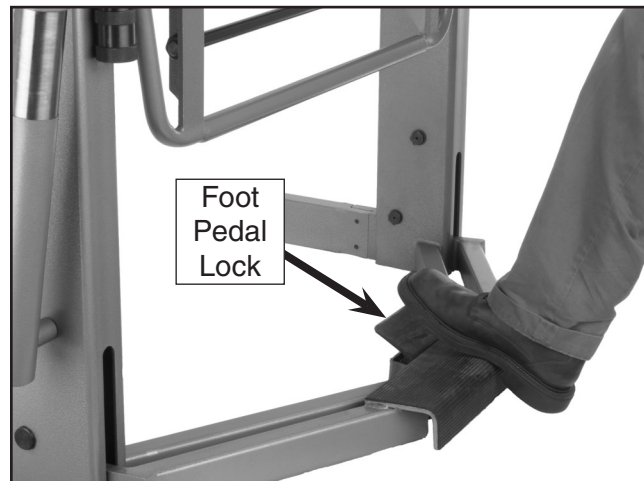

**Figure 14.** Foot pedal lock engaged.

If the clamping pressure has been adjusted (see *Adjusting Clamping Pressure*, **Page 18**.) We recommend using the foot pedal lock for better control when bending workpieces.

You can lower the fingers onto the workpiece without locking the foot pedal. However, you will have to keep the foot pedal depressed while moving the bending wing during bending operations.

### To release the foot pedal lock:

1. Press the foot pedal lock down to release the foot pedal. The pedal will raise back to its original position (**Figure 15**).

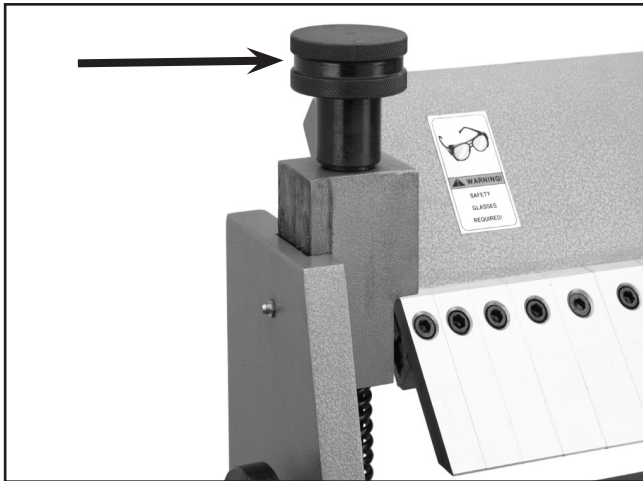

**Figure 15.** Foot pedal disengaged.



# Adjusting Clamping Pressure

The correct clamping pressure depends on the workpiece thickness. The ideal pressure will have medium/hard resistance and will lock the workpiece into position easily—much like a pair of vice grips. This pressure is adjusted by moving the clamping pressure adjusting nuts, shown in **Figure 16**, located on both sides of the pan and box brake.



**Figure 16.** Clamping pressure adjusting nut (one side).

## To adjust the clamping pressure:

1. Lower the bending leaf.
2. Place the workpiece between the fingers and the clamping block.
3. Push the foot pedal down and lock it in place.
  - If the foot pedal will not lock in place, loosen the clamping pressure evenly until it will lock.
  - If the foot pedal locks in place but the workpiece is not clamped snug, tighten the clamping pressure.



# Aligning Fingers

Finger alignment is critical for accurate results.

**Tools Needed:** **QTY**  
8MM Hex Wrench..... 1

## To align a finger:

1. Disengage the foot pedal.
2. Lower the bending leaf.
3. Loosen the cap screw(s) on a finger enough to move it up or down without resistance.
4. Push the finger firmly up against the lower edge of the clamping leaf and tighten the cap screw(s), as shown in **Figure 17**.



**Figure 17.** Tightening capscrew on finger.

*Continued on next page* →

5. Check the front edge of the fingers to see if they are aligned, as shown in **Figure 18**.



**Figure 18.** Finger edges aligned.

6. If an individual finger sticks out beyond the other fingers, loosen the cap screw(s), wiggle the finger up or down, retighten and check finger alignment.

Repeat **Steps 3-6** to align additional fingers.



# Spacing Fingers

The fingers can be spaced apart for clearance when making pans or boxes. This requires removing one or more of the fingers so that you can space the others to match the width of your pan or box.

**Tools Needed:** **QTY**  
 8MM Hex Wrench..... 1

### To space the fingers apart:

1. Remove the cap screws from each of the fingers you decide to remove.
2. Pull the fingers off the front guide, as shown in **Figure 19**, and set them aside.

*Note—You may need to mix and match finger widths to equal the size of your workpiece.*



**Figure 19.** Fingers removed to provide space for matching fingers with box or pan widths.

3. Align the remaining fingers and tighten the cap screws. (See **Page 18** for alignment instructions.)



# Basic Bending

## **! WARNING**

**Do not operate the Model G0578 unless it has been securely clamped in place or mounted to the floor, or it could tip over on you, causing a severe injury!**

Bending operations require the fingers to be parallel with the edge of the clamping block and require the setback and clamping pressure to be correctly adjusted for the thickness of the workpiece.

### To perform a basic bending operation:

1. Open the clamping leaf.
2. Insert the workpiece between the fingers and the clamping block.
3. Align the fingers to the bend mark on the workpiece, and clamp it in place.

*Note—If the foot pedal does not lock when you lower the fingers over the workpiece, the clamping pressure may need to be loosened. (See [Adjusting Clamping Pressure](#), [Page 18](#)).*

4. Lift the bending leaf until the workpiece has reached the desired bend angle.
5. Raise the clamping leaf and remove the bent workpiece.

*Note—If a pan or box bend is desired, choose a finger or a selection of fingers that are as close as possible to the length of the pan or box side lengths.*

## **! CAUTION**

**Hold onto the workpiece so it does not drop and hit you when it is released!**



# Setting Adjustable Stop

The Model G0578 features an adjustable stop so you can make repeated bends at the same angle.

### To set the adjustable stop:

1. Rotate the bending leaf to the desired bending angle.
2. Make sure the stop collar is snug against the stop block.
3. Tighten the stop collar cap screw, as shown in [Figure 20](#).

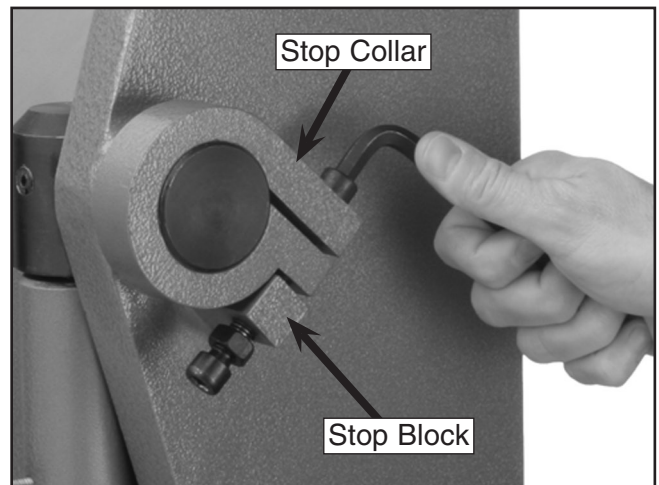

**Figure 20.** Setting adjustable stop.

4. Check that the stop collar is locked by moving the bending leaf up and down.
5. To make fine adjustments to the bending angle, turn the stop block cap screw clockwise or counterclockwise, then tighten the jam nut against the casting.
6. To select and lock a different bending angle, loosen the stop collar cap screw and repeat [Steps 1-5](#).



# Bending Allowance

---

---

To bend metal objects accurately, you need to consider the total length of each bend, especially when more than one bend is required. This is called bend allowance.

Subtract bend allowance from the sum of the workpiece outside dimensions to obtain the overall length and width of the blank needed to make a particular part.

Exact allowances can only be obtained by trial due to differences in sheet metal hardness, whether the bend is with or across the grain, and difficulties in making an exact bend radius. Bend allowances accurate enough for average use may be found in metalworking handbooks.



# SECTION 4: MAINTENANCE

## Lubrication

There are four main areas to keep lubricated on the Model G0578 Pan and Box Brake: 1) The unpainted cast iron surfaces, 2) the bending leaf hinge, 3) clamping leaf grease fittings, and 4) the setback knob threads.

### Cast Iron Surfaces

To prevent rust, all unpainted cast iron surfaces on the Model G0578 should be regularly maintained with a surface protectant like G96® GUN TREATMENT (Model H3788) or BOESHIELD® T-9 (Model G2871).

*Note—Check with the current Grizzly catalog for current pricing and a variety of other quality metal protectants.*

### Clamping Leaf

There are two grease fittings for the clamping leaf (see **Figure 21**). They should be greased at least once a week. Grease daily if your machine is under heavy, continuous use.

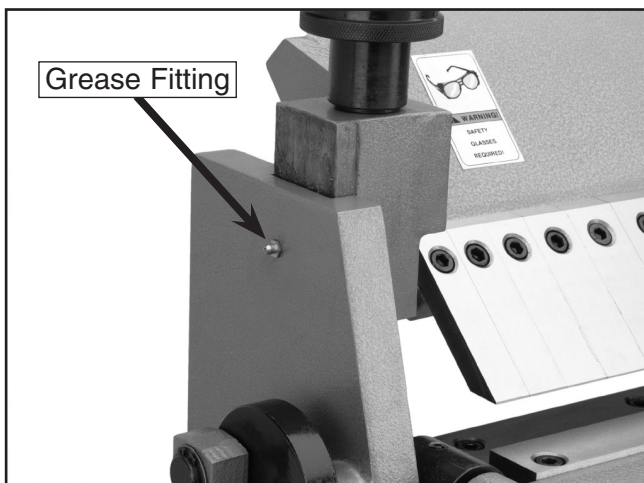

**Figure 21.** Grease fittings (only one side shown).

### Bending Leaf

Place an occasional dab of white lithium grease on the bending leaf hinge (**Figure 22**).

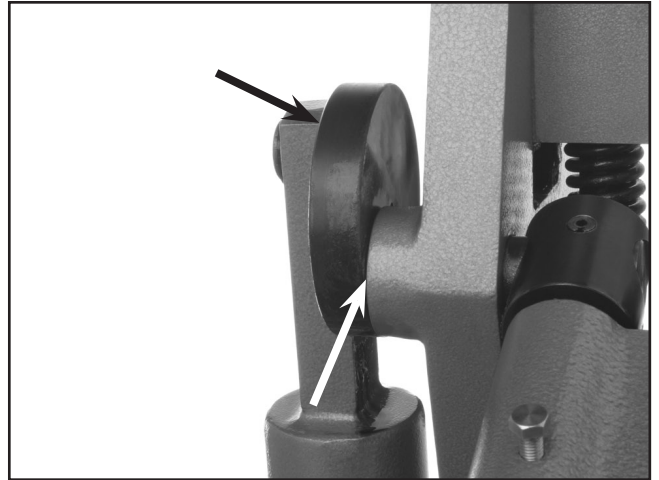

**Figure 22.** Location to lubricate hinge.

### Setback Knob Threads

The threads on the setback knobs (see **Figure 23**) may need an occasional dab of white lithium grease. The threads are easiest to reach if the setback is moved all the way forward or all the way backward. For best results, move the setback all the way back and forth one time after applying the grease; grease the threads as needed to maintain smooth operation from the knobs.

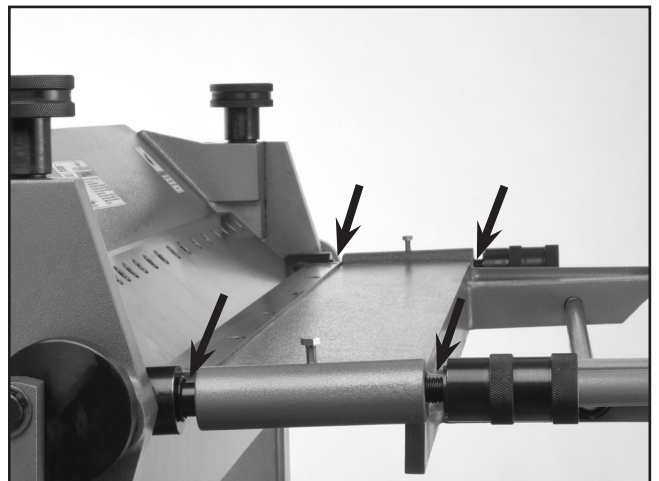

**Figure 23.** Location to lubricate setback threads.

# G0578 Parts Breakdown

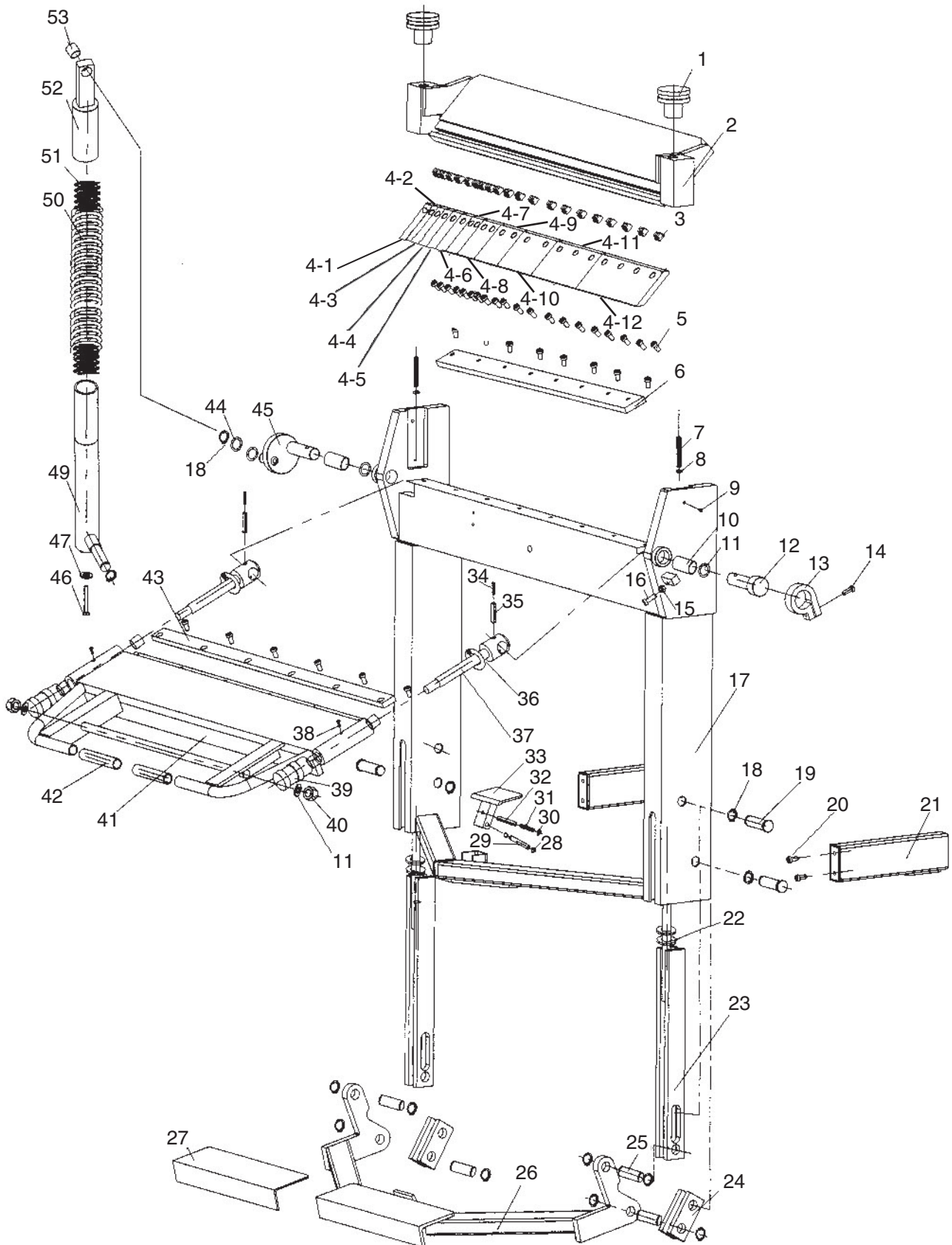

# G0578 Parts List

REF	PART #	DESCRIPTION
1	P0578001	ADJUSTING NUT
2	P0578002	CLAMPING LEAF
3	P0578003	T-NUT M10-1.5
4-1	P0578004-1	1" FINGER
4-2	P0578004-2	1-1/8" FINGER
4-3	P0578004-3	1-1/4" FINGER
4-4	P0578004-4	1-3/8" FINGER
4-5	P0578004-5	1-1/2" FINGER
4-6	P0578004-6	1-3/4" FINGER
4-7	P0578004-7	2" FINGER
4-8	P0578004-8	3" FINGER
4-9	P0578004-9	4" FINGER
4-10	P0578004-10	5" FINGER
4-11	P0578004-11	8" FINGER
4-12	P0578004-12	10" FINGER
5	PSB61M	CAP SCREW M10-1.5 X 20
6	P0578006	CLAMPING BLOCK
7	P0578007	ADJUSTING NUT SPRING
8	PW13M	FLAT WASHER 20MM
9	P0578009	GREASE FITTING 8MM
10	P0578010	BUSHING
11	P0578011	FLAT WASHER 30MM
12	P0578012	FOLDING LEAF PIN
13	P0578013	STOP COLLAR
14	PSB84M	CAP SCREW M10-1.5 X 35
15	PN02M	HEX NUT M10-1.5
16	PSB47M	CAP SCREW M10-1.5 X 40
17	P0578017	LEG
18	PR11M	EXT RETAINING RING 25MM
19	P0578019	LEG PIN
20	PSB72M	CAP SCREW M10-1.5 X 30

REF	PART #	DESCRIPTION
21	P0578021	EXTENSION BRACKET
22	P0578022	DISC SPRING 40 X 20 X 1 X 2.4
23	P0578023	ROD
24	P0578024	FOOT PEDAL LEVER
25	P0578025	LEVER PIN
26	P0578026	FOOT PEDAL
27	P0578027	TREAD PLATE RUBBER
28	PR01M	EXT RETAINING RING 10MM
29	P0578029	ROLL PIN
30	PW01M	FLAT WASHER 8MM
31	P0578031	PEDAL LOCK SPRING
32	P0578032	SPRING PIN 8 X 50
33	P0578033	FOOT PEDAL LOCK
34	P0578034	SPRING PIN 6 X 50
35	P0578035	SPRING PIN 10 X 50
36	P0578036	O-RING 33 X 25
37	P0578037	SETBACK HANDLE
38	PB87M	HEX BOLT M8-1.25 X 15
39	P0578039	SETBACK KNOB
40	PN28M	HEX NUT M20-2.5
41	P0578041	BENDING LEAF
42	P0578042	OPERATING HANDLE
43	P0578043	BENDING LEAF BLADE
44	P0578044	SHIM RING
45	P0578045	CRANK
46	P0578046	HEX BOLT M12-1.75 X 150
47	P0578047	STAR WASHER M12
49	P0578049	BOTTOM TELESCOPING STRUT
50	P0578050	SPRING
51	P0578051	SPIRAL BLOCK
52	P0578052	TOP TELESCOPING STRUT
53	P0578053	BUSHING

# WARRANTY AND RETURNS

---

Grizzly Industrial, Inc. warrants every product it sells for a period of **1 year** to the original purchaser from the date of purchase. This warranty does not apply to defects due directly or indirectly to misuse, abuse, negligence, accidents, repairs or alterations or lack of maintenance. This is Grizzly's sole written warranty and any and all warranties that may be implied by law, including any merchantability or fitness, for any particular purpose, are hereby limited to the duration of this written warranty. We do not warrant or represent that the merchandise complies with the provisions of any law or acts unless the manufacturer so warrants. In no event shall Grizzly's liability under this warranty exceed the purchase price paid for the product and any legal actions brought against Grizzly shall be tried in the State of Washington, County of Whatcom.

We shall in no event be liable for death, injuries to persons or property or for incidental, contingent, special, or consequential damages arising from the use of our products.

To take advantage of this warranty, contact us by mail or phone and give us all the details. We will then issue you a "Return Number," which must be clearly posted on the outside as well as the inside of the carton. We will not accept any item back without this number. Proof of purchase must accompany the merchandise.

The manufacturers reserve the right to change specifications at any time because they constantly strive to achieve better quality equipment. We make every effort to ensure that our products meet high quality and durability standards and we hope you never need to use this warranty.

Please feel free to write or call us if you have any questions about the machine or the manual.

Thank you again for your business and continued support. We hope to serve you again soon.



# WARRANTY CARD

Name \_\_\_\_\_  
 Street \_\_\_\_\_  
 City \_\_\_\_\_ State \_\_\_\_\_ Zip \_\_\_\_\_  
 Phone # \_\_\_\_\_ Email \_\_\_\_\_ Invoice # \_\_\_\_\_  
 Model # \_\_\_\_\_ Order # \_\_\_\_\_ Serial # \_\_\_\_\_

*The following information is given on a voluntary basis. It will be used for marketing purposes to help us develop better products and services. **Of course, all information is strictly confidential.***

**1. How did you learn about us?**

Advertisement                       Friend                       Catalog  
 Card Deck                               Website                       Other:

**2. Which of the following magazines do you subscribe to?**

<input type="checkbox"/> Cabinet Maker	<input type="checkbox"/> Popular Mechanics	<input type="checkbox"/> Today's Homeowner
<input type="checkbox"/> Family Handyman	<input type="checkbox"/> Popular Science	<input type="checkbox"/> Wood
<input type="checkbox"/> Hand Loader	<input type="checkbox"/> Popular Woodworking	<input type="checkbox"/> Wooden Boat
<input type="checkbox"/> Handy	<input type="checkbox"/> Practical Homeowner	<input type="checkbox"/> Woodshop News
<input type="checkbox"/> Home Shop Machinist	<input type="checkbox"/> Precision Shooter	<input type="checkbox"/> Woodsmith
<input type="checkbox"/> Journal of Light Cont.	<input type="checkbox"/> Projects in Metal	<input type="checkbox"/> Woodwork
<input type="checkbox"/> Live Steam	<input type="checkbox"/> RC Modeler	<input type="checkbox"/> Woodworker West
<input type="checkbox"/> Model Airplane News	<input type="checkbox"/> Rifle	<input type="checkbox"/> Woodworker's Journal
<input type="checkbox"/> Modeltec	<input type="checkbox"/> Shop Notes	<input type="checkbox"/> Other:
<input type="checkbox"/> Old House Journal	<input type="checkbox"/> Shotgun News	

**3. What is your annual household income?**

\$20,000-\$29,000                       \$30,000-\$39,000                       \$40,000-\$49,000  
 \$50,000-\$59,000                       \$60,000-\$69,000                       \$70,000+

**4. What is your age group?**

20-29                                       30-39                                       40-49  
 50-59                                       60-69                                       70+

**5. How long have you been a woodworker/metalworker?**

0-2 Years                       2-8 Years                       8-20 Years                       20+ Years

**6. How many of your machines or tools are Grizzly?**

0-2                                       3-5                                       6-9                                       10+

**7. Do you think your machine represents a good value?**

Yes                                       No

**8. Would you recommend Grizzly Industrial to a friend?**

Yes                                       No

**9. Would you allow us to use your name as a reference for Grizzly customers in your area?**

Note: *We never use names more than 3 times.*

Yes                                       No

**10. Comments:** \_\_\_\_\_  
 \_\_\_\_\_  
 \_\_\_\_\_  
 \_\_\_\_\_

CUT ALONG DOTTED LINE

FOLD ALONG DOTTED LINE

\_\_\_\_\_  
\_\_\_\_\_  
\_\_\_\_\_



Place  
Stamp  
Here



**GRIZZLY INDUSTRIAL, INC.**  
**P.O. BOX 2069**  
**BELLINGHAM, WA 98227-2069**



FOLD ALONG DOTTED LINE

Send a Grizzly Catalog to a friend:

Name \_\_\_\_\_  
Street \_\_\_\_\_  
City \_\_\_\_\_ State \_\_\_\_\_ Zip \_\_\_\_\_

TAPE ALONG EDGES--PLEASE DO NOT STAPLE





# *grizzly.com*

**TOOL WEBSITE**

Buy Direct and Save with Grizzly® – Trusted, Proven and a Great Value!

*Visit Our Website Today And Discover Why  
Grizzly® Is The Industry Leader!*

- SECURE ORDERING
- ORDERS SHIPPED WITHIN 24 HOURS
- E-MAIL RESPONSE WITHIN ONE HOUR

-OR-

Call Today For A **FREE**  
Full Color Catalog

**1-800-523-4777**

